



**TENDER NO.: SC 1758/2017**

**SUPPLY AND DELIVERY OF PLUMBING MATERIAL, PLUMBING TOOLS AND  
IRRIGATION ITEMS FOR A CONTRACT PERIOD ENDING 30 JUNE 2020**

**PROCUREMENT DOCUMENT**

<b>NAME OF TENDERER:</b>	
<b>Total Bid Price (Inclusive of VAT)</b>	<b>REFER TO PRICING SCHEDULE ON PAGES 99 TO 151</b>

**FEBRUARY 2017**

**PREPARED AND ISSUED BY:**

Directorate: Finance:  
Supply Chain Management Unit  
Overstrand Municipality  
PO Box 20, Hermanus, 7200

**CONTACT FOR ENQUIRIES  
REGARDING SPECIFICATIONS:**

**JC van der Merwe**  
**SCM Practitioner: Stores**  
Tel. Number: **028 313 5027**

<b>KLEINMOND</b> Private Bag X3 Kleinmond; 7195 Tel: 028 271 8100 Fax: 028 271 4678	<b>HERMANUS</b> PO Box 20 Hermanus; 7200 Tel: 028 313 8000 Fax: 028 313 8048	<b>STANFORD</b> PO Box 84 Stanford; 7210 Tel: 028 341 0640 Fax: 028 341 0445	<b>GANSBAAI</b> PO Box 26 Gansbaai; 7220 Tel: 028 384 0111 Fax: 028 384 0241
---	--	--	--

TENDER DETAILS					
TENDER NUMBER:	<b>SC1758/2017</b>				
TENDER TITLE:	<b>SUPPLY AND DELIVERY OF PLUMBING MATERIAL, PLUMBING TOOLS AND IRRIGATION ITEMS FOR A CONTRACT PERIOD ENDING 30 JUNE 2020</b>				
CLOSING DATE:	<b>2017/03/31</b>		CLOSING TIME:	<b>12H00</b>	
SITE MEETING:	DATE:	<b>N/A</b>	TIME:	<b>N/A</b>	COMPULSORY: <b>N/A</b>
SITE MEETING ADDRESS:	<b>N/A</b>				
CIDB GRADING REQUIRED:	<b>NO</b>	LEVEL AND CATEGORY:	<b>N/A</b>		
BID BOX NO:	<b>4</b>	SITUATED AT: Overstrand Municipal Building, Magnolia Avenue, Hermanus. The bid box is generally open 24 hours a day, 7 days a week.			
OFFER TO BE VALID FOR:	<b>150</b>	DAYS FROM THE CLOSING DATE OF BID.			

TENDERER DETAILS (Please indicate postal address for all correspondence relevant to this specific tender)			
NAME OF TENDERER:			
NAME OF CONTACT PERSON:			
PHYSICAL ADDRESS:		POSTAL ADDRESS:	
TELEPHONE #:		FAX NO.:	
E-MAIL ADDRESS:			

DATE:	
SIGNATURE OF TENDERER:	
CAPACITY UNDER WHICH THIS BID IS SIGNED:	

PLEASE NOTE:
1. Tenders that are deposited in the incorrect box will not be considered.
2. Tender box deposit slot is 28cm x 2.5cm.
3. Mailed, telegraphic or faxed tenders will not be accepted.
4. If the bid is late, it will not be accepted for consideration.
5. Bids may only be submitted on the Bid Documentation provided by the Municipality.

ENQUIRIES MAY BE DIRECTED TO:	CONTACT PERSON	TEL. NUMBER
1. TECHNICAL ENQUIRIES	<b>JC van der Merwe</b>	<b>028 313 5027</b>
2. ENQUIRIES REGARDING BID PROCEDURES & COMPLETION OF BID DOCUMENTS	<b>A Moore</b>	<b>028 313 8974</b>
	<b>L du Preez</b>	<b>028 313 8147</b>

---

**CONTENTS**

	<b>PAGE NUMBER</b>
<b>PART A – ADMINISTRATIVE REQUIREMENTS IN TERMS OF THE SUPPLY CHAIN MANAGEMENT POLICY .....</b>	<b>4</b>
1. CHECKLIST .....	5
2. TENDER NOTICE & INVITATION TO TENDER .....	6
3. AUTHORITY TO SIGN A BID.....	7
4. GENERAL CONDITIONS OF CONTRACT – GOVERNMENT PROCUREMENT .....	11
5. GENERAL CONDITIONS OF TENDER .....	20
6. MBD 2 – TAX CLEARANCE CERTIFICATE REQUIREMENTS .....	24
7. MBD 4 – DECLARATION OF INTEREST .....	25
8. MBD5 – DECLARATION FOR PROCUREMENT ABOVE R10 MILLION (VAT INCLUDED).....	28
9. MBD6.1 – PREFERENCE POINTS CLAIM FORM IN TERMS OF THE PREFERENTIAL PROCUREMENT REGULATIONS 2011 – PURCHASES/SERVICES (90/10).....	29
10. MBD 6.2. – DECLARATION CERTIFICATE FOR LOCAL PRODUCTION AND CONTENT FOR DESIGNATED SECTORS.....	37
11. MBD 8 – DECLARATION OF BIDDER'S PAST SUPPLY CHAIN MANAGEMENT PRACTICES.....	50
12. MBD 9 – CERTIFICATE OF INDEPENDENT BID DETERMINATION.....	52
13. MBD 15 – CERTIFICATE FOR PAYMENT OF MUNICIPAL SERVICES.....	54
14. MBD 16 – KEY PERFORMANCE INDICATORS .....	55
15. SECTION 37(2) OF THE OCCUPATIONAL HEALTH AND SAFETY ACT, NO 85 OF 1993 .....	56
16. INDEMNITY.....	58
<b>PART B – SPECIFICATIONS AND PRICING .....</b>	<b>59</b>
17. SPECIFICATIONS .....	60
18. PRICING SCHEDULE.....	99
19. MBD 7.1. – CONTRACT FORM - PURCHASE OF GOODS.....	152
20. DECLARATION BY TENDERER .....	154
<b>PART C – DATABASE REGISTRATION .....</b>	<b>155</b>



**PART A – ADMINISTRATIVE REQUIREMENTS IN  
TERMS OF THE SUPPLY CHAIN MANAGEMENT POLICY**

<b>1. CHECKLIST</b>
---------------------

**PLEASE ENSURE THAT THE FOLLOWING FORMS HAVE BEEN DULY COMPLETED AND SIGNED AND THAT ALL DOCUMENTS AS REQUESTED, ARE ATTACHED TO THE TENDER DOCUMENT:**

<b>Authority to Sign a Bid</b> - Is the form duly completed and is a <b>certified copy</b> of the <b>resolution</b> attached?	Yes	No	
<b>Authority to sign for a Joint venture - Bid</b> - Is the form duly completed and is a <b>certified copy</b> of the <b>resolution</b> attached?	Yes	No	
<b>MBD 2</b> (Tax Clearance Certificate) - Is an <b>ORIGINAL</b> and <b>VALID</b> Tax Clearance Certificate attached?	Yes	No	
<b>MBD 4</b> (Declaration of Interest) - Is the form duly completed and signed?	Yes	No	
<b>MBD 6.1</b> (Preference Points claim form for purchases/services) - Is the form duly completed and signed? Is a <b>CERTIFIED</b> copy of the <b>B-BBEE Certificate</b> or the <b>original B-BBEE Certificate</b> attached?	Yes	No	
<b>MBD 6.2</b> (Declaration in terms of Local Content) - Is the form duly completed and signed?			
<b>MBD 8</b> (Declaration of Past Supply Chain Practices) - Is the form duly completed and signed?	Yes	No	
<b>MBD 9</b> (Certificate of Independent Bid Determination) - Is the form duly completed and signed?	Yes	No	
<b>MBD 15</b> (Certificate of Payment of Municipal Accounts) - Is the form duly completed and signed? Are the <b>Identity numbers, residential addresses</b> and <b>municipal account numbers</b> of <b>ALL</b> members, partners, directors, etc. provided on the form as requested?	Yes	No	
<b>MBD16</b> (Key Performance Indicators) - Is the form duly completed and signed?	Yes	No	
<b>OHASA</b> (Occupational Health and Safety) - Is the form duly completed and signed? Is a valid <b>Letter of Good Standing</b> from the Compensation Commissioner attached?	Yes	No	
<b>Indemnity</b> - Is the form duly completed and signed?	Yes	No	
<b>Specifications</b> - Is the form duly completed and signed?	Yes	No	
<b>Pricing Schedule</b> - Is the form duly completed and signed?	Yes	No	
<b>MBD 7.1</b> (Contract form – Goods) - Is the form duly completed and signed?	Yes	No	
<b>DATA BASE REGISTRATION</b> - Is the form duly completed and signed? Are <b>ALL</b> the supporting documents attached?	Yes	No	

SIGNATURE		NAME (PRINT)	
CAPACITY		DATE	
NAME OF FIRM			

**2. TENDER NOTICE & INVITATION TO TENDER****TENDER NO. SC 1758/2017****SUPPLY AND DELIVERY OF PLUMBING MATERIAL, PLUMBING TOOLS AND IRRIGATION  
ITEMS FOR A CONTRACT PERIOD ENDING 30 JUNE 2020**

Tenders are hereby invited for the **Supply and Delivery of Plumbing Material, Plumbing tools and Irrigation items for a contract period ending 30 June 2020.**

Tender documents, in English, are obtainable from **Friday, 24 February 2017**, at the offices of the Supply Chain Management Unit, Overstrand Municipality, Magnolia Avenue, Hermanus; from Ms. Rita Neethling Tel. 028 313 8064 between 08h30 and 15h30 upon payment of a tender participation fee of **R668-00** per set. Alternatively the document may be downloaded free of charge from the website: [www.overstrand.gov.za](http://www.overstrand.gov.za) .

Sealed tenders, with “**Tender No.: SC1758/2017: Supply and Delivery of Plumbing Material, Plumbing tools and Irrigation items for a contract period ending 30 June 2020.**” clearly endorsed on the envelope, must be deposited in **Tender Box No. 4** at the offices of the Overstrand Municipality, Magnolia Avenue, Hermanus. Bids may only be submitted on the bid documentation issued by Overstrand Municipality.

The closing date and time of the tender is on **31 March 2017** at **12h00** and tenders will be opened in public immediately thereafter in the Supply Chain Management Committee Room, Hermanus Administration.

Please refer enquiries to **JC van der Merwe** at telephone number: **028 313 5027**.



**3. AUTHORITY TO SIGN A BID**

**TYPE OF ENTERPRISE (Please indicate with an "X" and complete the indicated section below)**

1	Company (Pty) Ltd. & Ltd.		Please complete <b>section 1</b> below
2	Close Corporation (CC)		Please complete <b>section 2</b> below
3	Sole Proprietor		Please complete <b>section 3</b> below
4	Partnership		Please complete <b>section 4</b> below
5	Consortium, Club, Trust, etc.		Please complete <b>section 5</b> below
6	Joint Venture		Please complete <b>section 6</b> below

**1. COMPANIES - (PTY) LTD. & LTD.**

1.1. If a bidder is a **COMPANY ((Pty) Ltd. OR Ltd.)**, a certified copy of the resolution by the board of directors, duly signed, authorising the person who signs this bid to do so, as well as to sign any contract resulting from this bid and any other documents and correspondence in connection with this bid and/or contract on behalf of the company must be submitted with this bid, that is, before the closing time and date of the bid.

1.2. A valid resolution must be signed by:

- 1.2.1. Majority directors; or
- 1.2.2. Chairman of the Board; or
- 1.2.3. Company Secretary

**PARTICULARS OF RESOLUTION BY THE BOARD OF DIRECTORS OF THE COMPANY**

Date resolution was taken			
Resolution signed by (name and surname)			
Capacity			
Name and surname of delegated authorised signatory			
Capacity			
Specimen signature			
Full name and surname of ALL director(s)			
Is a copy of the resolution attached?	<b>YES</b>		<b>NO</b>
SIGNED ON BEHALF OF COMPANY / CC:		DATE:	
PRINT NAME:			
WITNESS 1:		WITNESS 2:	

**2. CLOSE CORPORATION (CC)**

2.1. In the case of a **CLOSE CORPORATION (CC)** submitting a bid, a resolution by its members, authorizing a member or other official of the corporation to sign the documents on their behalf, shall be included with the bid.

2.2. A valid resolution must be signed by:

2.2.1. Majority members; or

2.2.2. Member with majority shareholding but only if such shareholding is more than 50%; or

2.2.3. Company Secretary.

**PARTICULARS OF RESOLUTION BY THE MEMBERS OF THE CLOSE CORPORATION**

Date resolution was taken			
Resolution signed by (name and surname)			
Capacity			
Name and surname of delegated authorised signatory			
Capacity			
Specimen signature			
Full name and surname of ALL director(s) / member (s)			
Is a copy of the resolution attached?	YES		NO
SIGNED ON BEHALF OF COMPANY / CC:		DATE:	
PRINT NAME:			
WITNESS 1:		WITNESS 2:	

**3. SOLE PROPRIETOR (SINGLE OWNER BUSINESS) & NATURAL PERSON**

I, \_\_\_\_\_, the undersigned, hereby confirm that I am the sole owner of the business trading as \_\_\_\_\_.

**OR**

I, \_\_\_\_\_, the undersigned, hereby confirm that I am submitting this bid in my capacity as natural person.

SIGNATURE:		DATE:	
PRINT NAME:			
WITNESS 1:		WITNESS 2:	



**4. PARTNERSHIP**

We, the undersigned partners in the business trading as \_\_\_\_\_  
hereby authorize Mr / Ms \_\_\_\_\_ to sign this bid as well as any  
contract resulting from the bid and any other documents and correspondence in connection with this bid  
and /or contract for and on behalf of the abovementioned partnership.

**The following particulars in respect of every partner must be furnished and signed by every partner:**

Full name of partner	Signature

SIGNED ON BEHALF OF PARTNERSHIP:		DATE:	
PRINT NAME:			
WITNESS 1:		WITNESS 2:	

**5. CONSORTIUM / CLUB / TRUST / ETC.**

We, the undersigned consortium partners, hereby authorize \_\_\_\_\_  
(Name of entity) to act as lead consortium partner and further authorize Mr / Ms \_\_\_\_\_  
to sign this offer as well as any contract resulting from this bid and any other documents and  
correspondence in connection with this bid and / or contract for and on behalf of the consortium.

**The following particulars in respect of each consortium member must be provided and must be signed by each member:**

Full Name of consortium member	Role of consortium member	% Participation	Signature

SIGNED ON BEHALF OF PARTNERSHIP:		DATE:	
PRINT NAME:			
WITNESS 1:		WITNESS 2:	



**6. JOINT VENTURE**

We, the undersigned, are submitting this bid offer in joint venture and hereby authorize Mr / Ms \_\_\_\_\_

\_\_\_\_\_

authorized signatory of the Company / Close Corporation / Partnership (name) \_\_\_\_\_

\_\_\_\_\_

acting in the capacity of lead partner, to sign all documents in connection with the bid offer and any contract resulting from it on our behalf.

**1. LEAD PARTNER (Whom the Municipality shall hold liable for the purpose of the tender)**

Name of firm			
Address			
		Tel. No.	
Signature		Designation	

**2. 2<sup>nd</sup> PARTNER**

Name of firm			
Address			
		Tel. No.	
Signature		Designation	

**3. 3<sup>rd</sup> PARTNER**

Name of firm			
Address:			
		Tel. No.	
Signature		Designation	

**4. 4<sup>th</sup> PARTNER**

Name of firm			
Address:			
		Tel. No.	
Signature		Designation	

**NOTE:** A copy of the Joint Venture Agreement indicating clearly the percentage contribution of each partner to the Joint Venture, is to be submitted with the bid.

A board resolution, authorising each signatory who signed above to do so, is to be submitted with the bid.

#### 4. GENERAL CONDITIONS OF CONTRACT – GOVERNMENT PROCUREMENT

##### 1. DEFINITIONS

The following terms shall be interpreted as indicated:

- 1.1. "Closing time" means the date and hour specified in the bidding documents for the receipt of bids.
- 1.2. "Contract" means the written agreement entered into between the purchaser and the supplier, as recorded in the contract form signed by the parties, including all attachments and appendices thereto and all documents incorporated by reference therein.
- 1.3. "Contract price" means the price payable to the supplier under the contract for the full and proper performance of his contractual obligations.
- 1.4. "Corrupt practice" means the offering, giving, receiving, or soliciting of anything of value to influence the action of a public official in the procurement process or in contract execution.
- 1.5. "Countervailing duties" are imposed in cases where an enterprise abroad is subsidized by its government and encouraged to market its products internationally
- 1.6. "Country of origin" means the place where the goods were mined, grown or produced or from which the services are supplied. Goods are produced when, through manufacturing, processing or substantial and major assembly of components, a commercially recognized new product results that is substantially different in basic characteristics or in purpose or utility from its components.
- 1.7. "Day" means calendar day.
- 1.8. "Delivery" means delivery in compliance of the conditions of the contract or order.
- 1.9. "Delivery ex stock" means immediate delivery directly from stock actually on hand
- 1.10. "Delivery into consignees store or to his site" means delivered and unloaded in the specified store or depot or on the specified site in compliance with the conditions of the contract or order, the supplier bearing all risks and charges involved until the supplies are so delivered and a valid receipt is obtained.
- 1.11. "Dumping" occurs when a private enterprise abroad market its goods on own initiative in the RSA at lower prices than that of the country of origin and which have the potential to harm the local industries in the RSA.
- 1.12. "Force majeure" means an event beyond the control of the supplier and not involving the supplier's fault or negligence and not foreseeable.
- 1.13. Such events may include, but is not restricted to, acts of the purchaser in its sovereign capacity, wars or revolutions, fires, floods, epidemics, quarantine restrictions and freight embargoes.
- 1.14. "Fraudulent practice" means a misrepresentation of facts in order to influence a procurement process or the execution of a contract to the detriment of any bidder, and includes collusive practice among bidders (prior to or after bid submission) designed to establish bid prices at artificial non-competitive levels and to deprive the bidder of the benefits of free and open competition.
- 1.15. "GCC" means the General Conditions of Contract.
- 1.16. "Goods" means all of the equipment, machinery, and/or other materials that the supplier is required to supply to the purchaser under the contract.
- 1.17. "Imported content" means that portion of the bidding price represented by the cost of components, parts or materials which have been or are still to be imported (whether by the supplier or his subcontractors) and which costs are inclusive of the costs abroad, plus freight and other direct importation costs such as landing costs, dock dues, import duty, sales duty or other similar tax or duty at the South African place of entry as well as transportation and handling charges to the factory in the Republic where the supplies covered by the bid will be manufactured.

<b>INITIALS</b>	
-----------------	--



- 1.18. "Local content" means that portion of the bidding price which is not included in the imported content provided that local manufacture does take place.
- 1.19. "Manufacture" means the production of products in a factory using labour, materials, components and machinery and includes other related value-adding activities.
- 1.20. "Order" means an official written order issued for the supply of goods or works or the rendering of a service.
- 1.21. "Project site" where applicable, means the place indicated in bidding documents.
- 1.22. "Purchaser" means the organization purchasing the goods.
- 1.23. "Republic" means the Republic of South Africa.
- 1.24. "SCC" means the Special Conditions of Contract.
- 1.25. "Services" means those functional services ancillary to the supply of the goods, such as transportation and any other incidental services, such as installation, commissioning, provision of technical assistance, training, catering, gardening, security, maintenance and other such obligations of the supplier covered under the contract.
- 1.26. "Supplier" means the successful bidder who is awarded the contract to maintain and administer the required and specified service(s) to the State.
- 1.27. "Tort" means in breach of contract.
- 1.28. "Turnkey" means a procurement process where one service provider assumes total responsibility for all aspects of the project and delivers the full end product / service required by the contract.
- 1.29. "Written" or "in writing" means handwritten in ink or any form of electronic or mechanical writing.

**2. APPLICATION**

- 2.1. These general conditions are applicable to all bids, contracts and orders including bids for functional and professional services, sales, hiring, letting and the granting or acquiring of rights, but excluding immovable property, unless otherwise indicated in the bidding documents.
- 2.2. Where applicable, special conditions of contract are also laid down to cover specific supplies, services or works.
- 2.3. Where such special conditions of contract are in conflict with these general conditions, the special conditions shall apply.

**3. GENERAL**

- 3.1. Unless otherwise indicated in the bidding documents, the purchaser shall not be liable for any expense incurred in the preparation and submission of a bid. Where applicable a non-refundable fee for documents may be charged.
- 3.2. Invitations to bid are usually published in locally distributed news media and on the municipality / municipal entity website.

**4. STANDARDS**

The goods supplied shall conform to the standards mentioned in the bidding documents and specifications.

**5. USE OF CONTRACT DOCUMENTS AND INFORMATION; INSPECTION.**

- 5.1. The supplier shall not, without the purchaser's prior written consent, disclose the contract, or any provision thereof, or any specification, plan, drawing, pattern, sample, or information furnished by or on behalf of the purchaser in connection therewith, to any person other than a person employed by the supplier in the performance of the contract. Disclosure to any such employed person shall be made in confidence and shall extend only as far as may be necessary for purposes of such performance.

<b>INITIALS</b>	
-----------------	--



- 5.2. The supplier shall not, without the purchaser’s prior written consent, make use of any document or information mentioned in GCC clause 5.1 except for purposes of performing the contract.
- 5.3. Any document, other than the contract itself mentioned in GCC clause 5.1 shall remain the property of the purchaser and shall be returned (all copies) to the purchaser on completion of the supplier’s performance under the contract if so required by the purchaser.
- 5.4. The supplier shall permit the purchaser to inspect the supplier’s records relating to the performance of the supplier and to have them audited by auditors appointed by the purchaser, if so required by the purchaser.

**6. PATENT RIGHTS**

- 6.1. The supplier shall indemnify the purchaser against all third-party claims of infringement of patent, trademark, or industrial design rights arising from use of the goods or any part thereof by the purchaser.
- 6.2. When a supplier developed documentation / projects for the municipality / municipal entity, the intellectual, copy and patent rights or ownership of such documents or projects will vest in the municipality / municipal entity.

**7. PERFORMANCE SECURITY**

- 7.1. Within thirty (30) days of receipt of the notification of contract award, the successful bidder shall furnish to the purchaser the performance security of the amount specified in SCC.
- 7.2. The proceeds of the performance security shall be payable to the purchaser as compensation for any loss resulting from the supplier’s failure to complete his obligations under the contract.
- 7.3. The performance security shall be denominated in the currency of the contract or in a freely convertible currency acceptable to the purchaser and shall be in one of the following forms:
  - 7.3.1. bank guarantee or an irrevocable letter of credit issued by a reputable bank located in the purchaser’s country or abroad, acceptable to the purchaser, in the form provided in the bidding documents or another form acceptable to the purchaser; or
  - 7.3.2. a cashier’s or certified cheque
- 7.4. The performance security will be discharged by the purchaser and returned to the supplier not later than thirty (30) days following the date of completion of the supplier’s performance obligations under the contract, including any warranty obligations, unless otherwise specified.

**8. INSPECTIONS, TESTS AND ANALYSES**

- 8.1. All pre-bidding testing will be for the account of the bidder.
- 8.2. If it is a bid condition that supplies to be produced or services to be rendered should at any stage during production or execution or on completion be subject to inspections tests and analysis, the bidder or contractor’s premises shall be open, at all reasonable hours, for inspection by a representative of the purchaser or an organization acting on behalf of the purchaser.
- 8.3. If there are no inspection requirements indicated in the bidding documents and no mention is made in the contract, but during the contract period it is decided that inspections shall be carried out, the purchaser shall itself make the necessary arrangements, including payment arrangements with the testing authority concerned.
- 8.4. If the inspections, tests and analyses referred to in clauses 8.2 and 8.3 show the goods to be in accordance with the contract requirements, the cost of the inspections, tests and analyses shall be defrayed by the purchaser.
- 8.5. Where the goods or services referred to in clauses 8.2 and 8.3 do not comply with the contract requirements, irrespective of whether such goods or services are accepted or not, the cost in connection with these inspections, tests or analyses shall be defrayed by the supplier.
- 8.6. Supplies and services which are referred to in clauses 8.2 and 8.3 and which do not comply with the contract requirements may be rejected.

<b>INITIALS</b>	
-----------------	--



- 8.7. Any contract goods may on or after delivery be inspected, tested or analyzed and may be rejected if found not to comply with the requirements of the contract. Such rejected goods shall be held at the cost and risk of the supplier who shall, when called upon, remove them immediately at his own cost and forthwith substitute them with goods which do comply with the requirements of the contract. Failing such removal the rejected goods shall be returned at the suppliers cost and risk. Should the supplier fail to provide the substitute goods forthwith, the purchaser may, without giving the supplier further opportunity to substitute the rejected goods, purchase such goods as may be necessary at the expense of the supplier.
- 8.8. The provisions of clauses 8.4 to 8.7 shall not prejudice the right of the purchaser to cancel the contract on account of a breach of the conditions thereof, or to act in terms of Clause 22 of GCC.

**9. PACKING**

- 9.1. The supplier shall provide such packing of the goods as is required to prevent their damage or deterioration during transit to their final destination, as indicated in the contract. The packing shall be sufficient to withstand, without limitation, rough handling during transit and exposure to extreme temperatures, salt and precipitation during transit, and open storage. Packing, case size and weights shall take into consideration, where appropriate, the remoteness of the goods' final destination and the absence of heavy handling facilities at all points in transit.
- 9.2. The packing, marking, and documentation within and outside the packages shall comply strictly with such special requirements as shall be expressly provided for in the contract, including additional requirements, and in any subsequent instructions ordered by the purchaser.

**10. DELIVERY**

Delivery of the goods shall be made by the supplier in accordance with the documents and terms specified in the contract. The details of shipping and/or other documents to be furnished by the supplier are specified.

**11. INSURANCE**

The goods supplied under the contract shall be fully insured in a freely convertible currency against loss or damage incidental to manufacture or acquisition, transportation, storage and delivery in the manner specified.

**12. TRANSPORTATION**

Should a price other than an all-inclusive delivered price be required, this shall be specified.

**13. INCIDENTAL**

- 13.1. The supplier may be required to provide any or all of the following services, including additional services, if any:
  - 13.1.1. performance or supervision of on-site assembly and/or commissioning of the supplied goods;
  - 13.1.2. furnishing of tools required for assembly and/or maintenance of the supplied goods;
  - 13.1.3. furnishing of a detailed operations and maintenance manual for each appropriate unit of the supplied goods;
  - 13.1.4. performance or supervision or maintenance and/or repair of the supplied goods, for a period of time agreed by the parties, provided that this service shall not relieve the supplier of any warranty obligations under this contract; and
  - 13.1.5. training of the purchaser's personnel, at the supplier's plant and/or on-site, in assembly, start-up, operation, maintenance, and/or repair of the supplied goods.
- 13.2. Prices charged by the supplier for incidental services, if not included in the contract price for the goods, shall be agreed upon in advance by the parties and shall not exceed the prevailing rates charged to other parties by the supplier for similar services.

<b>INITIALS</b>	
-----------------	--



**14. SPARE PARTS**

- 14.1. As specified, the supplier may be required to provide any or all of the following materials, notifications, and information pertaining to spare parts manufactured or distributed by the supplier:
  - 14.1.1. such spare parts as the purchaser may elect to purchase from the supplier, provided that this election shall not relieve the supplier of any warranty obligations under the contract; and;
  - 14.1.2. in the event of termination of production of the spare parts:
    - 14.1.2.1. advance notification to the purchaser of the pending termination, in sufficient time to permit the purchaser to procure needed requirements; and
    - 14.1.2.2. following such termination, furnishing at no cost to the purchaser, the blueprints, drawings, and specifications of the spare parts, if requested.

**15. WARRANTY**

- 15.1. The supplier warrants that the goods supplied under the contract are new, unused, of the most recent or current models, and that they incorporate all recent improvements in design and materials unless provided otherwise in the contract. The supplier further warrants that all goods supplied under this contract shall have no defect, arising from design, materials, or workmanship (except when the design and/or material is required by the purchaser's specifications) or from any act or omission of the supplier, that may develop under normal use of the supplied goods in the conditions prevailing in the country of final destination.
- 15.2. This warranty shall remain valid for twelve (12) months after the goods, or any portion thereof as the case may be, have been delivered to and accepted at the final destination indicated in the contract, or for eighteen (18) months after the date of shipment from the port or place of loading in the source country, whichever period concludes earlier, unless specified otherwise in SCC.
- 15.3. The purchaser shall promptly notify the supplier in writing of any claims arising under this warranty.
- 15.4. Upon receipt of such notice, the supplier shall, within the period specified in SCC and with all reasonable speed, repair or replace the defective goods or parts thereof, without costs to the purchaser.
- 15.5. If the supplier, having been notified, fails to remedy the defect(s) within the period specified, the purchaser may proceed to take such remedial action as may be necessary, at the supplier's risk and expense and without prejudice to any other rights which the purchaser may have against the supplier under the contract.

**16. PAYMENT**

- 16.1. The method and conditions of payment to be made to the supplier under this contract shall be specified.
- 16.2. The supplier shall furnish the purchaser with an invoice accompanied by a copy of the delivery note and upon fulfillment of other obligations stipulated in the contract.
- 16.3. Payments shall be made by the purchaser no later than thirty (30) days after submission of an invoice, statement or claim by the supplier.
- 16.4. Payment will be made in Rand unless otherwise stipulated.

**17. PRICES**

Prices charged by the supplier for goods delivered and services performed under the contract shall not vary from the prices quoted by the supplier in his bid, with the exception of any price adjustments authorized or in the purchaser's request for bid validity extension, as the case may be.

<b>INITIALS</b>	
-----------------	--



**18. VARIATION ORDERS**

In cases where the estimated value of the envisaged changes in purchase does not vary more than 15% of the total value of the original contract, the contractor may be instructed to deliver the goods or render the services as such. In cases of measurable quantities, the contractor may be approached to reduce the unit price and such offers, may be accepted provided that there is no escalation in price.

**19. ASSIGNMENT**

The supplier shall not assign, in whole or in part, its obligations to perform under the contract, except with the purchaser's prior written consent.

**20. SUBCONTRACTS**

The supplier shall notify the purchaser in writing of all subcontracts awarded under this contract, if not already specified in the bid. Such notification, in the original bid or later, shall not relieve the supplier from any liability or obligation under the contract.

**21. DELAYS IN THE SUPPLIER'S PERFORMANCE**

- 21.1. Delivery of the goods and performance of services shall be made by the supplier in accordance with the time schedule prescribed by the purchaser in the contract.
- 21.2. If at any time during performance of the contract, the supplier or its subcontractor(s) should encounter conditions impeding timely delivery of the goods and performance of services, the supplier shall promptly notify the purchaser in writing of the fact of the delay, its likely duration and its cause(s). As soon as practicable after receipt of the supplier's notice, the purchaser shall evaluate the situation and may at his discretion extend the supplier's time for performance, with or without the imposition of penalties, in which case the extension shall be ratified by the parties by amendment of contract.
- 21.3. The right is reserved to procure outside of the contract small quantities or to have minor essential services executed if an emergency arises, the supplier's point of supply is not situated at or near the place where the supplies are required, or the supplier's services are not readily available.
- 21.4. Except as provided under GCC Clause 25, a delay by the supplier in the performance of its delivery obligations shall render the supplier liable to the imposition of penalties, pursuant to GCC Clause 22, unless an extension of time is agreed upon pursuant to GCC Clause 22 without the application of penalties.
- 21.5. Upon any delay beyond the delivery period in the case of a supplies contract, the purchaser shall, without cancelling the contract, be entitled to purchase supplies of a similar quality and up to the same quantity in substitution of the goods not supplied in conformity with the contract and to return any goods delivered later at the supplier's expense and risk, or to cancel the contract and buy such goods as may be required to complete the contract and without prejudice to his other rights, be entitled to claim damages from the supplier.

**22. PENALTIES**

Subject to GCC Clause 25, if the supplier fails to deliver any or all of the goods or to perform the services within the period(s) specified in the contract, the purchaser shall, without prejudice to its other remedies under the contract, deduct from the contract price, as a penalty, a sum calculated on the delivered price of the delayed goods or unperformed services using the current prime interest rate calculated for each day of the delay until actual delivery or performance. The purchaser may also consider termination of the contract pursuant to GCC Clause 23.

**23. TERMINATION FOR DEFAULT**

- 23.1. The purchaser, without prejudice to any other remedy for breach of contract, by written notice of default sent to the supplier, may terminate this contract in whole or in part:
  - 23.1.1. if the supplier fails to deliver any or all of the goods within the period(s) specified in the contract, or within any extension thereof granted by the purchaser pursuant to GCC Clause 21.2;

<b>INITIALS</b>	
-----------------	--

- 23.1.2. if the Supplier fails to perform any other obligation(s) under the contract; or
- 23.1.3. if the supplier, in the judgment of the purchaser, has engaged in corrupt or fraudulent practices in competing for or in executing the contract.
- 23.2. In the event the purchaser terminates the contract in whole or in part, the purchaser may procure, upon such terms and in such manner as it deems appropriate, goods, works or services similar to those undelivered, and the supplier shall be liable to the purchaser for any excess costs for such similar goods, works or services. However, the supplier shall continue performance of the contract to the extent not terminated.
- 23.3. Where the purchaser terminates the contract in whole or in part, the purchaser may decide to impose a restriction penalty on the supplier by prohibiting such supplier from doing business with the public sector for a period not exceeding 10 years.
- 23.4. If a purchaser intends imposing a restriction on a supplier or any person associated with the supplier, the supplier will be allowed a time period of not more than fourteen (14) days to provide reasons why the envisaged restriction should not be imposed. Should the supplier fail to respond within the stipulated fourteen (14) days the purchaser may regard the supplier as having no objection and proceed with the restriction.
- 23.5. Any restriction imposed on any person by the purchaser will, at the discretion of the purchaser, also be applicable to any other enterprise or any partner, manager, director or other person who wholly or partly exercises or exercised or may exercise control over the enterprise of the first-mentioned person, and with which enterprise or person the first-mentioned person, is or was in the opinion of the purchase actively associated.
- 23.6. If a restriction is imposed, the purchaser must, within five (5) working days of such imposition, furnish the National Treasury, with the following information:
- 23.6.1. the name and address of the supplier and / or person restricted by the purchaser;
- 23.6.2. the date of commencement of the restriction
- 23.6.3. the period of restriction; and
- 23.6.4. the reasons for the restriction.
- These details will be loaded in the National Treasury's central database of suppliers or persons prohibited from doing business with the public sector.
- 23.7. If a court of law convicts a person of an offence as contemplated in sections 12 or 13 of the Prevention and Combating of Corrupt Activities Act, No. 12 of 2004, the court may also rule that such person's name be endorsed on the Register for Tender Defaulters. When a person's name has been endorsed on the Register, the person will be prohibited from doing business with the public sector for a period not less than five years and not more than 10 years. The National Treasury is empowered to determine the period of restriction and each case will be dealt with on its own merits. According to section 32 of the Act the Register must be open to the public. The Register can be perused on the National Treasury website.

#### 24. ANTI-DUMPING AND COUNTERVAILING DUTIES AND RIGHTS

When, after the date of bid, provisional payments are required, or antidumping or countervailing duties are imposed, or the amount of a provisional payment or anti-dumping or countervailing right is increased in respect of any dumped or subsidized import, the State is not liable for any amount so required or imposed, or for the amount of any such increase. When, after the said date, such a provisional payment is no longer required or any such anti-dumping or countervailing right is abolished, or where the amount of such provisional payment or any such right is reduced, any such favourable difference shall on demand be paid forthwith by the contractor to the State or the State may deduct such amounts from moneys (if any) which may otherwise be due to the contractor in regard to supplies or services which he delivered or rendered, or is to deliver or render in terms of the contract or any other contract or any other amount which may be due to him.

INITIALS	
----------	--

**25. FORCE MAJEURE**

- 25.1. Notwithstanding the provisions of GCC Clauses 22 and 23, the supplier shall not be liable for forfeiture of its performance security, damages, or termination for default if and to the extent that his delay in performance or other failure to perform his obligations under the contract is the result of an event of force majeure.
- 25.2. If a force majeure situation arises, the supplier shall promptly notify the purchaser in writing of such condition and the cause thereof. Unless otherwise directed by the purchaser in writing, the supplier shall continue to perform its obligations under the contract as far as is reasonably practical, and shall seek all reasonable alternative means for performance not prevented by the force majeure event.

**26. TERMINATION FOR INSOLVENCY**

The purchaser may at any time terminate the contract by giving written notice to the supplier if the supplier becomes bankrupt or otherwise insolvent. In this event, termination will be without compensation to the supplier, provided that such termination will not prejudice or affect any right of action or remedy which has accrued or will accrue thereafter to the purchaser.

**27. SETTLEMENT OF DISPUTES**

- 27.1. If any dispute or difference of any kind whatsoever arises between the purchaser and the supplier in connection with or arising out of the contract, the parties shall make every effort to resolve amicably such dispute or difference by mutual consultation.
- 27.2. If, after thirty (30) days, the parties have failed to resolve their dispute or difference by such mutual consultation, then either the purchaser or the supplier may give notice to the other party of his intention to commence with mediation. No mediation in respect of this matter may be commenced unless such notice is given to the other party.
- 27.3. Should it not be possible to settle a dispute by means of mediation, it may be settled in a South African court of law.
- 27.4. Notwithstanding any reference to mediation and/or court proceedings herein,
- 27.4.1. the parties shall continue to perform their respective obligations under the contract unless they otherwise agree; and
- 27.4.2. the purchaser shall pay the supplier any monies due for goods delivered and / or services rendered according to the prescripts of the contract.

**28. LIMITATION OF LIABILITY**

- 28.1. Except in cases of criminal negligence or wilful misconduct, and in the case of infringement pursuant to Clause 6;
- 28.1.1. the supplier shall not be liable to the purchaser, whether in contract, tort, or otherwise, for any indirect or consequential loss or damage, loss of use, loss of production, or loss of profits or interest costs, provided that this exclusion shall not apply to any obligation of the supplier to pay penalties and/or damages to the purchaser; and
- 28.1.2. the aggregate liability of the supplier to the purchaser, whether under the contract, in tort or otherwise, shall not exceed the total contract price, provided that this limitation shall not apply to the cost of repairing or replacing defective equipment

**29. GOVERNING LANGUAGE**

The contract shall be written in English. All correspondence and other documents pertaining to the contract that is exchanged by the parties shall also be written in English.

**30. APPLICABLE LAW**

The contract shall be interpreted in accordance with South African laws, unless otherwise specified.

INITIALS	
----------	--

**31. NOTICES**

- 31.1. Every written acceptance of a bid shall be posted to the supplier concerned by registered or certified mail and any other notice to him shall be posted by ordinary mail to the address furnished in his bid or to the address notified later by him in writing and such posting shall be deemed to be proper service of such notice
- 31.2. The time mentioned in the contract documents for performing any act after such aforesaid notice has been given, shall be reckoned from the date of posting of such notice.

**32. TAXES AND DUTIES**

- 32.1. A foreign supplier shall be entirely responsible for all taxes, stamp duties, license fees, and other such levies imposed outside the purchaser's country.
- 32.2. A local supplier shall be entirely responsible for all taxes, duties, license fees, etc., incurred until delivery of the contracted goods to the purchaser.
- 32.3. No contract shall be concluded with any bidder whose tax matters are not in order. Prior to the award of a bid SARS must have certified that the tax matters of the preferred bidder are in order.
- 32.4. No contract shall be concluded with any bidder whose municipal rates and taxes and municipal services charges are in arrears.

**33. TRANSFER OF CONTRACTS**

The contractor shall not abandon, transfer, cede, assign or sublet a contract or part thereof without the written permission of the purchaser.

**34. AMENDMENT OF CONTRACTS**

No agreement to amend or vary a contract or order or the conditions, stipulations or provisions thereof shall be valid and of any force unless such agreement to amend or vary is entered into in writing and signed by the contracting parties. Any waiver of the requirement that the agreement to amend or vary shall be in writing, shall also be in writing.

**35. PROHIBITION OF RESTRICTIVE PRACTICES.**

- 35.1. In terms of section 4 (1) (b) (iii) of the Competition Act No. 89 of 1998, as amended, an agreement between, or concerted practice by, firms, or a decision by an association of firms, is prohibited if it is between parties in a horizontal relationship and if a bidder(s) is / are or a contractor(s) was / were involved in collusive bidding.
- 35.2. If a bidder(s) or contractor(s) based on reasonable grounds or evidence obtained by the purchaser has / have engaged in the restrictive practice referred to above, the purchaser may refer the matter to the Competition Commission for investigation and possible imposition of administrative penalties as contemplated in section 59 of the Competition Act No 89 Of 1998.
- 35.3. If a bidder(s) or contractor(s) has / have been found guilty by the Competition Commission of the restrictive practice referred to above, the purchaser may, in addition and without prejudice to any other remedy provided for, invalidate the bid(s) for such item(s) offered, and / or terminate the contract in whole or part, and / or restrict the bidder(s) or contractor(s) from conducting business with the public sector for a period not exceeding ten (10) years and / or claim damages from the bidder(s) or contractor(s) concerned.

*General Conditions of Contract (revised July 2010)*

<b>INITIALS</b>	
-----------------	--

## 5. GENERAL CONDITIONS OF TENDER

### 1. GENERAL

- 1.1. All bids must be submitted in **handwriting** on the official forms supplied (**not to be re-typed**)
- 1.2. No alterations /corrections to the information in the document (including pricing) may be performed by erasing or using masking fluid / tape (Tipp-Ex or similar) on any submitted page or by pasting another page over it with glue.
- 1.3. Alterations/corrections may only be executed as follows:
  - 1.3.1. Strike a line through the incorrect information, write the corrected information as appropriate (under, above or next to the information to be corrected), and initial at every alteration/correction.
  - 1.3.2. Bid submissions with material alterations / corrections not in compliance with the requirements as described above, will be rejected.
  - 1.3.3. All alterations to the pricing schedule / Bill of Quantities (BoQ) and / or any pricing not in accordance with clause 1.3.1 above, will be rejected.

### 2. PRICING

- 2.1. Rates and prices offered by the bidder must be written onto the pricing schedule or form of offer of this document by hand, completed in full and signed by the duly authorised signatory.
- 2.2. All prices shall be quoted in South African currency, and be **INCLUSIVE of VAT**.
- 2.3. Bid prices must include all expenses, disbursements and costs (e.g. transport, accommodation etc.) which may be required for the execution of the bidder's obligations in terms of the Contract. Bid prices shall cover the cost of all general risks, liabilities and obligations set forth or implied in the Contract, as well as overhead charges and profit (in the event that the bid is successful), unless otherwise specified.
- 2.4. All bid prices will be final and binding.
  - 2.4.1. A bid will not be invalidated if the amount in words and the amount in figures do not correspond,
  - 2.4.2. in which case the amount in words shall be read out at the bid opening and shall be deemed to be the bid amount; therefore, where there is a discrepancy between the amount in figures and the amount in words, the amount in words shall apply-

### 3. FORWARD EXCHANGE RATE COVER

- 3.1. In the event of price(s) based on the exchange rate, the successful bidder(s) will be required to obtain exchange rate cover in order to protect the Municipality against exchange rate variations.
- 3.2. The bidder must provide proof of forward exchange rate cover within 14 days after an order was placed.
- 3.3. If proof that forward exchange rate cover was taken out within 14 days after the order was placed but is not submitted to the Municipality along with the invoice, the contract price adjustment will not be accepted and the contract may be cancelled.

### 4. SUBMITTING A BID:

- 4.1. Sealed bids, with the "**Bid Number and Title**" clearly endorsed on the envelope, must be deposited in the relevant **bid box** as indicated in the notice of the bid, **on or before the closing date and time** of the bid.
- 4.2. The bid boxes are in the Main Cash Hall, Hermanus Municipal Offices, 2 Magnolia Avenue, Hermanus.

<b>INITIALS</b>	
-----------------	--

- 4.3. A specific bid box is provided for each bid to be deposited into and no bid will be considered which, subsequent to the closing date and time for that specific bid, is found in another box.
- 4.4. The bid box deposit slot is 28cm x 2.5cm.
- 4.5. Mailed, telegraphic, e-mailed or faxed bids **will not be accepted**.

## 5. BID OPENING

- 5.1. Bids shall be opened in public at the Hermanus Municipal Offices as soon as possible subsequent to the closing time for the receipt of bids.
- 5.2. The Municipality will record in a register (which is open to public inspection) and publish on its website, the details of bids received by the closing date and time.
- 5.3. Any bid received after the appointed time for the closing of bids **shall not be considered** but shall be filed unopened with the other bids received, which bid(s) can be returned to the bidder at his request and cost.

## 6. BIDS WILL BE EVALUATED AND ADJUDICATED ACCORDING TO THE FOLLOWING CRITERIA:

- 6.1. Relevant specifications;
- 6.2. Value for money;
- 6.3. Capability to execute the contract; and
- 6.4. PPPFA & associated regulations

## 7. TEST FOR RESPONSIVENESS:

- 7.1. A Bids will be considered non-responsive if:
  - 7.1.1. the bid is not in compliance with the specifications;
  - 7.1.2. the bidder has not fully completed and signed where required, all the returnable documents as listed in the bid document; and/or
  - 7.1.3. the bidder has failed to clarify or submit any supporting documentation within 2-5 business days of being requested to do so in writing.
- 7.2. The Municipality reserves the right to accept or reject:
  - 7.2.1. any variation, deviation, bid offer, or alternative bid offer; may cancel the bidding process and reject all bid offers at any time before the formation of a contract. The MUNICIPALITY shall not accept or incur any liability to a bidder for such cancellation and/or rejection, and will only provide written reasons for such action upon receipt of a written request to do so;.
  - 7.2.2. a bid offer which does not, in the Municipality's opinion, materially and/or substantially deviate from the terms, conditions and specifications of the bid document.
  - 7.2.3. the whole bid or part of a bid or any item or part of any item, or to accept more than one bid (in the event of a number of items being offered), and the Municipality is not obliged to accept the lowest or any bid.
- 7.3. The bidder shall declare ALL the Municipal account numbers for which the enterprise or the proprietors or directors in their personal capacity/capacities is/ are responsible or co-responsible for;
  - 7.3.1. The Municipality has the right to summarily disqualify any bidder who, either at the date of submission of a bid or at the date of its award, is indebted to the Municipality in respect of any municipal rates and taxes or municipal service charges for more than three months. However, an agreement signed by the bidder whereby the bidder agrees that a percentage or fixed amount at the discretion of the municipality, be deducted from payments due to him/her for this bid, until the debt is paid in full, will also be accepted by the Municipality.

INITIALS	
----------	--

**8. INCORRECT INFORMATION**

Where a contract has been awarded on the strength of the information furnished by the bidder which after the conclusion of the relevant agreement, is proven to have been incorrect, the municipality may, in addition to any other legal remedy it has or may have, recover from the contractor all costs, losses or damages incurred or sustained by the municipality as a result of the award of the contract.

**9. WITHDRAWAL OF BID DURING AND AFTER THE SCM PROSES:**

- 9.1. When a bidder withdraws his/her bid during the SCM bidding process, it must be in writing, prior to the award of the bid, of which Overstrand holds the right to accept or reject with or without a claim for any damages.
- 9.2. When a bidder withdraws or cancels the contract after award of the bid to the particular winner of the bid, the awarded bidder will be held responsible for any damages or administrative expenses incurred prior to the award of the bid.

**10. INVOICES**

All invoices must be forwarded to the following address:

Overstrand Municipality  
PO Box 20  
Hermanus, 7200

**10.1. Legal requirements for invoices**

- 10.1.1. Please ensure that your tax invoices complies with the requirements as stipulated by SARS (VAT Act No 89 of 1991), i.e.:

**10.1.1.1. Ordinary invoice (not VAT Registered)**

- a) The word '**INVOICE**' in a prominent place
- b) Official invoice number and date of transaction
- c) Trade name, legal name, registration number (if any) and address of supplier
- d) The Official order number of Overstrand Municipality is compulsory – non-compliance – no payment
- e) The Municipality's name and postal address (PO Box 20, Hermanus, 7200)
- f) Accurate description of goods and / or services supplied / provided.
- g) Unit of measurement of goods or services supplied
- h) Price

- 10.1.1.2. **VAT/Tax invoice (VAT registered)** An example of a valid Tax Invoice is attached as **Annexure C**.

- a) Word '**TAX INVOICE**' in a prominent place
- b) Trade, legal name and registration number(if any) of supplier
- c) Address and VAT number of supplier
- d) The official invoice number and date of invoice
- e) The Official order number of Overstrand Municipality is compulsory – non-compliance – no payment
- f) The Municipality's name and postal address (PO Box 20, Hermanus, 7200) and VAT registration number (4140106396)
- g) Accurate description of goods and / or services supplied / provided.
- h) Unit of measurement of goods or services supplied
- i) Price and VAT amount

<b>INITIALS</b>	
-----------------	--

## 11. PAYMENT TERMS

- 11.1. It is the policy of the Overstrand Municipality to pay all creditors by means of electronic bank transfers.
- 11.2. Creditors will be paid within 30 days after receipt of an invoice and statement for the month in question, detailing all invoices during that month and reflecting the total amount due by the Municipality. In exceptional circumstances, the Municipality may, at its discretion, deviate from the above.
- 11.3. In order to qualify for a weekly payment, a supplier must be registered as a **Survivalist Enterprise / Micro Enterprise**<sup>1</sup> on the Municipality's supplier database. It must however be noted, that a weekly payment is not a right in terms of this Policy. Survivalist and Micro enterprises may request such payments which may then be made at the discretion of the Municipality. These weekly payments will be reviewed after a period of 12 months of doing business with the Municipality, as it may be assumed that the enterprise will, by that stage be self-sustainable. It is the obligation of the supplier to arrange earlier payments with the creditors department.

## 12. PRECEDENCE OF TERMS AND CONDITIONS

- 12.1. Precedence of terms and conditions in documentation during the bidding process and after award, resulting in an formal agreement:
- 12.1.1. The following precedence will apply to documentation and legislation during the bidding process and after award of a bid to a bidder:
- 12.1.1.1. Municipal Financial Management Act 56 of 2003
  - 12.1.1.2. Municipal Supply Chain Management Regulations
  - 12.1.1.3. Supply Chain Management policy
  - 12.1.1.4. Specifications of the bid document
  - 12.1.1.5. Special Conditions of Contract
  - 12.1.1.6. General Conditions of Contract
  - 12.1.1.7. Service Level Agreements/ Service Delivery Agreements
  - 12.1.1.8. Memorandum of Understanding/ Memorandum of Agreements

### <sup>1</sup> SURVIVALIST ENTERPRISES / MICRO ENTERPRISES ARE DEFINED AS FOLLOWS:

**Survivalist enterprises** are generally defined as businesses set up by people unable to find a paid job or get into an economic sector of their choice. Income generated from these activities usually falls far short of even a minimum income standard, with very little capital invested, virtually no skills training in the particular field and only limited opportunities for growth into a viable business. This category is characterised by poverty and the attempt to survive.

**Micro enterprises** are very small businesses, often involving only the owner, some family members and at the most one or two paid employees. They usually lack 'formality' in terms of business licenses, value-added tax (VAT) registration, formal business premises, operating permits and accounting procedures. Most of them have a limited capital base and only rudimentary technical or business skills among their operators. However, many micro enterprises advance into viable small businesses. Earning levels of micro enterprises differ widely, depending on the particular sector, the growth phase of the business and access to relevant support.

<b>INITIALS</b>	
-----------------	--



**6. MBD 2 – TAX CLEARANCE CERTIFICATE REQUIREMENTS**

It is a condition of bid that the taxes of the successful bidder **must** be in order, or that satisfactory arrangements have been made with South African Revenue Services (SARS) to meet the bidder’s tax obligations.

1. In order to meet this requirement, bidders are required to complete in full the TCC 0001 form, “Application for a Tax Clearance Certificate” and submit it to any SARS branch office nationally or on the website [www.sars.gov.za](http://www.sars.gov.za). The Tax Clearance Certificate Requirements are also applicable to foreign bidders / individuals who wish to submit bids.
2. Applications for the Tax Clearance Certificates may also be made via e-Filing. In order to use this provision, taxpayers will need to register with SARS as e-Fileers through the website [www.sars.gov.za](http://www.sars.gov.za)
3. SARS will then furnish the bidder with a Tax Clearance Certificate that will be valid for a period of 1 (one) year from the date of approval.
4. In bids where Consortia / Joint Ventures / Sub-Contractors are involved, each party must submit a separate Tax Clearance Certificate.
5. Tax Compliance Status (TCS) Pin as of 18 April 2016
  - a. In terms of the new Tax Compliance Status System implemented by SARS on 18 April 2016, taxpayers are now able to issue the municipality with a TCS Pin which can be used to verify a bidder’s tax status online via SARS E-filing.
  - b. The taxpayer must issue the municipality with the following:

<b>Bidders who are not in possession of an original Tax Clearance Certificate must provide at least 2 of the 3 numbers listed below in order to verify the Tax Clearance Certificate via SARS e-filing</b>		
<b>1</b>	Tax Reference Number:	
<b>2</b>	Tax Compliance Status Pin:	
<b>3</b>	Tax Clearance Certificate Number:	

- c. If a bidder is registered on the Overstrand Municipality Supplier’s Database and the Municipality is already in possession of an original tax clearance certificate which is valid on closing date of bid, it **MUST** be indicated as such on this page, whereby the attaching of a new tax clearance certificate to this page will not be needed.
6. Should a Tax Clearance Certificate not be verifiable on the SARS e-filing system, the bidder will be afforded an opportunity to submit a valid, verifiable Tax Clearance Certificate. It will result in the invalidation of the bid, should the bidder fail to provide a valid, verifiable Tax Clearance Certificate.

<b>INITIALS</b>	
-----------------	--



**7. MBD 4 – DECLARATION OF INTEREST**

1. No bid will be accepted from persons in the service of the state<sup>2</sup>.
2. Any person, having a kinship with persons in the service of the state, including a blood relationship, may make an offer or offers in terms of this invitation to bid. In view of possible allegations of favouritism, should the resulting bid, or part thereof, be awarded to persons connected with or related to persons in service of the state, it is required that the bidder or their authorised representative declare their position in relation to the evaluating/adjudging authority and/or take an oath declaring his/her interest.
3. In order to give effect to the above, the following questionnaire must be completed and submitted with the bid:

<b>3.1.</b>	<b>Full name of bidder or his or her representative</b>				
<b>3.2.</b>	<b>Identity number</b>				
<b>3.3.</b>	<b>Position occupied in the company (director, shareholder<sup>3</sup> etc.)</b>				
<b>3.4.</b>	<b>Company registration number</b>				
<b>3.5.</b>	<b>Tax reference number</b>				
<b>3.6.</b>	<b>VAT registration number</b>				
<b>3.7.</b>	<b>Are you presently in the service of the state?</b>	YES		NO	
3.7.1.	If so, furnish particulars:				
<b>3.8.</b>	<b>Have you been in the service of the state for the past twelve months?</b>	YES		NO	
3.8.1.	If so, furnish particulars:				

<sup>2</sup> MSCM Regulations: "in the service of the state" means to be –

- (a) a member of –
  - i. any municipal council;
  - ii. any provincial legislature; or
  - iii. the National Assembly or the National Council of Provinces;
- (b) a member of the board of directors of any municipal entity;
- (c) an official of any municipality or municipal entity;
- (d) an employee of any national or provincial department, national or provincial public entity or constitutional institution within the meaning of the Public Finance Management Act, 1999 (Act No.1 of 1999);
- (e) a member of the accounting authority of any national or provincial public entity; or
- (f) an employee of Parliament or a provincial legislature.

<sup>3</sup> "Shareholder" means a person who owns shares in the company and is actively involved in the management of the company or business and exercises control over the company.



3.9.	Do you have any relationship (family, friend, other) with persons in the service of the state and who may be involved with the evaluation and or adjudication of this bid?	YES		NO	
3.9.1.	If so, furnish particulars:				
3.10.	Are you aware of any relationship (family, friend, other) between a bidder and any persons in the service of the state who may be involved with the evaluation and or adjudication of this bid?	YES		NO	
3.10.1.	If so, furnish particulars:				
3.11.	Are any of the company's directors, managers, principal shareholders or stakeholders in the service of the state?	YES		NO	
3.11.1.	If so, furnish particulars:				
3.12.	Is any spouse, child or parent of the company's directors, managers, principal shareholders or stakeholders in the service of the state?	YES		NO	
3.12.1.	If so, furnish particulars:				
3.13.	Do you or any of the directors, trustees, managers, principal shareholders, or stakeholders of this company have any interest in any other related companies or business whether or not they are bidding for this contract?	YES		NO	
3.13.1.	If so, furnish particulars:				



<b>3.14.</b>	Please provide the following information on <b>ALL</b> directors / shareholders / trustees /members below:		
full name and surname	identity number	personal income tax number	Provide State <sup>4</sup> employee number <i>(Only to be completed if in the service of the State)</i>

**NB:**

- PLEASE ATTACH CERTIFIED COPY(IES) OF ID DOCUMENT(S)**
- PLEASE PROVIDE PERSONAL INCOME TAX NUMBERS FOR ALL DIRECTORS / SHAREHOLDERS / TRUSTEES / MEMBERS, ETC.**

**4. DECLARATION**

I, the undersigned (name) \_\_\_\_\_,

certify that the information furnished in paragraph 3 above is correct.

I accept that the state may act against me should this declaration prove to be false.

SIGNATURE		DATE	
NAME OF SIGNATORY			
POSITION			
NAME OF COMPANY			

<sup>4</sup> **MSCM Regulations: "in the service of the state" means to be –**

- (a) a member of –
  - i. any municipal council;
  - ii. any provincial legislature; or
  - iii. the National Assembly or the National Council of Provinces;
- (b) a member of the board of directors of any municipal entity;
- (c) an official of any municipality or municipal entity;
- (d) an employee of any national or provincial department, national or provincial public entity or constitutional institution within the meaning of the Public Finance Management Act, 1999 (Act No.1 of 1999);
- (e) a member of the accounting authority of any national or provincial public entity; or
- (f) an employee of Parliament or a provincial legislature.



**8. MBD5 – DECLARATION FOR PROCUREMENT ABOVE R10 MILLION (VAT INCLUDED)**

For all procurement expected to exceed R10 million (VAT included), bidders must complete the following questionnaire:

1. Are you by law required to prepare annual financial statements for auditing?	YES		NO	
1.1. If yes, submit audited annual financial statements for the past three years or since the date of establishment if established during the past three years.				
2. Do you have any outstanding undisputed commitments for municipal services towards a municipality or any other service provider in respect of which payment is overdue for more than 30 days?	YES		NO	
2.1. If no, this serves to certify that the bidder has no undisputed commitments for municipal services towards a municipality or other service provider in respect of which payment is overdue for more than 30 days.				
2.2. If yes, provide particulars.				
3. Has any contract been awarded to you by an organ of state during the past five years, including particulars of any material non-compliance or dispute concerning the execution of such contract?	YES		NO	
3.1. If yes, furnish particulars				
4. Will any portion of goods or services be sourced from outside the Republic, and, if so, what portion and whether any portion of payment from the municipality / municipal entity is expected to be transferred out of the Republic?	YES		NO	
4.1 If yes, furnish particulars				

**CERTIFICATION**

I, the undersigned (name) \_\_\_\_\_, certify that the information furnished on this declaration form is correct.

I accept that the state may act against me should this declaration prove to be false.

SIGNATURE		DATE	
NAME (PRINT)			
CAPACITY			
NAME OF FIRM			



**9. MBD6.1 – PREFERENCE POINTS CLAIM FORM IN TERMS OF THE PREFERENTIAL PROCUREMENT REGULATIONS 2011 – PURCHASES/SERVICES (90/10)**

**NB:**  
**Before completing this form, bidders must study the general conditions, definitions and directives applicable in respect of B-BBEE, as prescribed in the Preferential Procurement Regulations, 2011.**

**1. GENERAL CONDITIONS**

- 1.1. The following preference point systems are applicable to all bids:
  - 1.1.1. the 80/20 system for requirements with a Rand value of up to R1 000 000 (all applicable taxes included); and
  - 1.1.2. the 90/10 system for requirements with a Rand value above R1 000 000 (all applicable taxes included).
- 1.2. The value of this bid is estimated to exceed R1 000 000 (all applicable taxes included) and therefore the 90/10 preference point system shall be applicable.
- 1.3. Preference points for this bid shall be awarded for:
  - 1.3.1. Price; and
  - 1.3.2. B-BBEE Status Level of Contribution.
- 1.4. The maximum points for this bid are allocated as follows:

	POINTS
Price	90
B-BBEE status level of contribution	10
<b>Total points for Price and B-BBEE must not exceed</b>	<b>100</b>

- 1.5. Failure on the part of a bidder to submit a B-BBEE Verification Certificate from a Verification Agency accredited by the South African Accreditation System (SANAS), or a Registered Auditor approved by the Independent Regulatory Board of Auditors (IRBA) or an original sworn affidavit confirming annual turnover and level of black ownership in the case of an EME and QSE together with the bid, will be interpreted to mean that preference points for B-BBEE status level of contribution are not claimed.
- 1.6. The purchaser reserves the right to require of a bidder, either before a bid is adjudicated or at any time subsequently, to substantiate any claim in regard to preferences, in any manner required by the purchaser.

**2. DEFINITIONS**

- 2.1. **“all applicable taxes”** includes value-added tax, pay as you earn, income tax, unemployment insurance fund contributions and skills development levies;
- 2.2. **“B-BBEE”** means broad-based black economic empowerment as defined in section 1 of the Broad-Based Black Economic Empowerment Act;
- 2.3. **“B-BBEE status level of contributor”** means the B-BBEE status received by a measured entity based on its overall performance using the relevant scorecard contained in the Codes of Good Practice on Black Economic Empowerment, issued in terms of section 9(1) of the Broad-Based Black Economic Empowerment Act;
- 2.4. **“bid”** means a written offer in a prescribed or stipulated form in response to an invitation by an organ of state for the provision of services, works or goods, through price quotations, advertised competitive bidding processes or proposals;
- 2.5. **“Broad-Based Black Economic Empowerment Act”** means the Broad-Based Black Economic Empowerment Act, 2003 (Act No. 53 of 2003) as amended by Act No 46 of 2013;

- 2.6. **“comparative price”** means the price after the factors of a non-firm price and all unconditional discounts that can be utilized have been taken into consideration;
- 2.7. **“consortium or joint venture”** means an association of persons for the purpose of combining their expertise, property, capital, efforts, skill and knowledge in an activity for the execution of a contract;
- 2.8. **“contract”** means the agreement that results from the acceptance of a bid by an organ of state;
- 2.9. **“EME”** means an Exempted Micro Enterprise as defined by Codes of Good Practice issued in terms of section 9 (1) of the Broad-Based Black Economic Empowerment Act, 2003 (Act No. 53 of 2003);
- 2.10. **“Firm price”** means the price that is only subject to adjustments in accordance with the actual increase or decrease resulting from the change, imposition, or abolition of customs or excise duty and any other duty, levy, or tax, which, in terms of the law or regulation, is binding on the contractor and demonstrably has an influence on the price of any supplies, or the rendering costs of any service, for the execution of the contract;
- 2.11. **“functionality”** means the measurement according to predetermined norms, as set out in the bid documents, of a service or commodity that is designed to be practical and useful, working or operating, taking into account, among other factors, the quality, reliability, viability and durability of a service and the technical capacity and ability of a bidder;
- 2.12. **“non-firm prices”** means all prices other than “firm” prices;
- 2.13. **“person”** includes a juristic person;
- 2.14. **“QSE”** means a Qualifying Small Enterprise as defined by Codes of Good Practice issued in terms of section 9 (1) of the Broad-Based Black Economic Empowerment Act, 2003 ( Act No. 53 of 2003);
- 2.15. **“rand value”** means the total estimated value of a contract in South African currency, calculated at the time of bid invitations, and includes all applicable taxes and excise duties;
- 2.16. **“sub-contract”** means the primary contractor’s assigning, leasing, making out work to, or employing, another person to support such primary contractor in the execution of part of a project in terms of the contract;
- 2.17. **“total revenue”** bears the same meaning assigned to this expression in the Codes of Good Practice on Black Economic Empowerment, issued in terms of section 9(1) of the Broad-Based Black Economic Empowerment Act and promulgated in the *Government Gazette* on 9 February 2007;
- 2.18. **“trust”** means the arrangement through which the property of one person is made over or bequeathed to a trustee to administer such property for the benefit of another person; and
- 2.19. **“trustee”** means any person, including the founder of a trust, to whom property is bequeathed in order for such property to be administered for the benefit of another person.

### 3. ADJUDICATION USING A POINT SYSTEM

- 3.1. The bidder obtaining the highest number of total points will be awarded the contract.
- 3.2. Preference points shall be calculated after prices have been brought to a comparative basis taking into account all factors of non-firm prices and all unconditional discounts;
- 3.3. Points scored must be rounded off to the nearest 2 decimal places.
- 3.4. In the event that two or more bids have scored equal total points, the successful bid must be the one scoring the highest number of preference points for B-BBEE.
- 3.5. However, when functionality is part of the evaluation process and two or more bids have scored equal points including equal preference points for B-BBEE, the successful bid must be the one scoring the highest score for functionality.
- 3.6. Should two or more bids be equal in all respects, the award shall be decided by the drawing of lots.



**4. POINTS AWARDED FOR PRICE**

**4.1. THE 80/20 OR 90/10 PREFERENCE POINT SYSTEMS**

A maximum of 80 or 90 points is allocated for price on the following basis:

$$P_s = 80 \left( 1 - \frac{P_t - P_{\min}}{P_{\min}} \right) \quad \text{or} \quad P_s = 90 \left( 1 - \frac{P_t - P_{\min}}{P_{\min}} \right)$$

Where

- P<sub>s</sub> = Points scored for comparative price of bid under consideration
- P<sub>t</sub> = Comparative price of bid under consideration
- P<sub>min</sub> = Comparative price of lowest acceptable bid.

**5. POINTS AWARDED FOR B-BBEE STATUS LEVEL OF CONTRIBUTION**

5.1. In terms of Regulation 5(2) and 6(2) of the Preferential Procurement Regulations, preference points must be awarded to a bidder for attaining the B-BBEE status level of contribution in accordance with the table below:

B-BBEE Status Level of Contributor	Number of points (90/10 system)	Number of points (80/20 system)
1	10	20
2	9	18
3	8	16
4	5	12
5	4	8
6	3	6
7	2	4
8	1	2
Non-compliant contributor	0	0

- 5.2. A bidder who qualifies as an EME in terms of the B-BBEE Act must submit an original sworn affidavit confirming Annual Total Revenue and Level of Black Ownership.
- 5.3. A Bidder other than EME or QSE must submit their original and valid B-BBEE status level verification certificate or a certified copy thereof, substantiating their B-BBEE rating issued by a Registered Auditor approved by IRBA or a Verification Agency accredited by SANAS.
- 5.4. A trust, consortium or joint venture, will qualify for points for their B-BBEE status level as a legal entity, provided that the entity submits their B-BBEE status level certificate.
- 5.5. A trust, consortium or joint venture will qualify for points for their B-BBEE status level as an unincorporated entity, provided that the entity submits their consolidated B-BBEE scorecard as if they were a group structure and that such a consolidated B-BBEE scorecard is prepared for every separate bid.
- 5.6. Tertiary Institutions and Public Entities will be required to submit their B-BBEE status level certificates in terms of the specialized scorecard contained in the B-BBEE Codes of Good Practice.
- 5.7. A person will not be awarded points for B-BBEE status level if it is indicated in the bid documents that such a bidder intends sub-contracting more than 25% of the value of the contract to any other enterprise that does not qualify for at least the points that such a bidder qualifies for, unless the intended sub-contractor is an EME that has the capability and ability to execute the sub-contract.
- 5.8. A person awarded a contract may not sub-contract more than 25% of the value of the contract to any other enterprise that does not have an equal or higher B-BBEE status level than the person concerned, unless the contract is sub-contracted to an EME that has the capability and ability to execute the sub-contract.



**6. BID DECLARATION**

6.1. Bidders who claim points in respect of B-BBEE Status Level of Contribution must complete the following:

B-BBEE STATUS LEVEL OF CONTRIBUTION CLAIMED IN TERMS OF PARAGRAPHS 1.4 AND 5.1	
B-BBEE Status Level of Contribution as reflected on the B-BBEE Certificate	
Points claimed in respect of Level of Contribution (maximum of 10 or 20 points)	

(Points claimed in respect of paragraph 7.1 must be in accordance with the table reflected in paragraph 5.1 and must be substantiated by means of a B-BBEE certificate issued by a Verification Agency accredited by SANAS or a Registered Auditor approved by IRBA or a sworn affidavit.

**7. SUB-CONTRACTING**

Will any portion of the contract be sub-contracted? (Tick applicable box)	YES		NO	
If yes, indicate:				
what percentage of the contract will be subcontracted?	%			
the name of the sub-contractor?				
the B-BBEE status level of the sub-contractor?				
whether the sub-contractor is an EME? (Tick applicable box)	YES		NO	

**8. DECLARATION WITH REGARD TO COMPANY/FIRM**

Name of Enterprise			
VAT registration number			
Company registration number			
TYPE OF ENTERPRISE (Tick applicable box)	Partnership / Joint Venture / Consortium		
	One person business / sole proprietor		
	Company ((Pty) Ltd. / Ltd.)		
	Close Corporation (CC)		
Describe principal business activities			
Company Classification (Tick applicable box)	Manufacturer		
	Supplier		
	Professional service provider		
	Other service providers, e.g. transporter, etc.		
Total number of years the company/firm has been in business			



**10. MUNICIPAL INFORMATION**

Name of municipality where business is situated	
Registered municipal account number	
Stand number	
Total number of years the company/firm has been in business	

**11. DECLARATION**

I/we, the undersigned, who is / are duly authorised to do so on behalf of the company/firm, certify that the points claimed, based on the B-BBEE status level of contribution indicated in paragraph 7 of the foregoing certificate, qualifies the company/ firm for the preference(s) shown and I / we acknowledge that:

- 11.1. The information furnished is true and correct;
- 11.2. The preference points claimed are in accordance with the General Conditions as indicated in paragraph 1 of this form;
- 11.3. In the event of a contract being awarded as a result of points claimed as shown in paragraph 7, the contractor may be required to furnish documentary proof to the satisfaction of the purchaser that the claims are correct;
- 11.4. If the B-BBEE status level of contribution has been claimed or obtained on a fraudulent basis or any of the conditions of contract have not been fulfilled, the purchaser may, in addition to any other remedy it may have –
  - 11.4.1. disqualify the person from the bidding process;
  - 11.4.2. recover costs, losses or damages it has incurred or suffered as a result of that person’s conduct;
  - 11.4.3. cancel the contract and claim any damages which it has suffered as a result of having to make less favourable arrangements due to such cancellation;
  - 11.4.4. restrict the bidder or contractor, its shareholders and directors, or only the shareholders and directors who acted on a fraudulent basis, from obtaining business from any organ of state for a period not exceeding 10 years, after the *audi alteram partem* (hear the other side) rule has been applied; and
  - 11.4.5. forward the matter for criminal prosecution.

SIGNATURE OF BIDDER(S):			
WITNESS 1:		WITNESS 2:	
DATE:			
ADDRESS:			

---

**FOR INFORMATION PURPOSES ONLY**
**PLEASE NOTE THE FOLLOWING REQUIREMENTS REGARDING VALIDATION OF B-BBEE SCORE.**

---

**1. EMEs****ONLY THE FOLLOWING WILL BE ACCEPTED:**

- 1.1. **A VALID ORIGINAL** sworn affidavit, confirming annual turnover and level of black ownership **(form available in the tender document)**;  
or
- 1.2. **A VALID** affidavit / certificate issued by Companies Intellectual Property Commission (CIPC);  
or
- 1.3. **A VALID ORIGINAL** B-BBEE status level verification certificate **OR A CERTIFIED COPY** thereof, substantiating their B-BBEE rating issued by:
  - 1.3.1. A registered Auditor approved by the Independent Regulatory Board for Auditors (IRBA); or
  - 1.3.2. A verification Agency accredited by the South African National Accreditation System (SANAS).

**2. QSEs****ONLY THE FOLLOWING WILL BE ACCEPTED:**

- 2.1. **A VALID ORIGINAL** sworn affidavit, confirming annual turnover and level of black ownership **(form available in the tender document)**;  
or
- 2.2. **A VALID ORIGINAL** B-BBEE status level verification certificate **OR A CERTIFIED COPY** thereof, substantiating their B-BBEE rating issued by:
  - 2.2.1. A registered Auditor approved by IRBA; or
  - 2.2.2. A verification Agency accredited by SANAS.

**3. BIDDERS OTHER THAN EMEs AND QSEs**

- 3.1. The bidder **MUST** submit either a **VALID ORIGINAL B-BBEE** status level verification certificate **OR A CERTIFIED COPY** thereof, substantiating their **B-BBEE** rating issued by:
  - 3.1.1. A Registered Auditor approved by IRBA; or
  - 3.1.2. A Verification Agency accredited by SANAS.

**4. WHEN CONFIRMING THE VALIDITY OF CERTIFICATES ISSUED BY AN AUDITOR REGISTERED WITH IRBA, THE FOLLOWING SHOULD BE DETAILED ON THE FACE OF THE CERTIFICATE:**

- 4.1. The Auditor's letterhead with FULL contact details;
- 4.2. The Auditor's practice number;
- 4.3. The name and physical location of the measured entity;
- 4.4. The registration number and, where applicable, the VAT number of the measured entity;
- 4.5. The date of issue and date of expiry;
- 4.6. The B-BBEE Status Level of Contribution obtained by the measured entity; and
- 4.7. The total black shareholding and total black female shareholding.

MUNISIPALITEIT



MUNICIPALITY

---

**SWORN AFFIDAVIT – B-BBEE EXEMPTED MICRO ENTERPRISE**

---

I, the undersigned,			
<b>Full name</b>			
<b>Surname</b>			
<b>Identity number</b>			
Hereby declare under oath as follows:			
<b>1.</b>	The contents of this statement are to the best of my knowledge a true reflection of the facts.		
<b>2.</b>	I am a member / director / owner of the following enterprise and am duly authorised to act on its behalf:		
	<b>Enterprise Legal Name</b>		
	<b>Trading Name</b>		
	<b>Registration Number</b>		
	<b>Enterprise Address</b>		
	<b>Definition of "Black People"</b>	<p>As per the Broad-Based Black Economic Empowerment Act 53 of 2003 as Amended by Act No 46 of 2013 "Black People" is a generic term which means Africans, Coloureds and Indians –</p> <p>(a) Who are citizens of the Republic of South Africa by birth or descent; or</p> <p>(b) Who became citizens of the Republic of South Africa by naturalization-</p> <p>i. Before 27 April 1994; or</p> <p>ii. On or after 27 April 1994 and who would have been entitled to acquire citizenship by naturalization prior to that date</p>	
<b>3.</b>	I hereby declare under oath that:		
	<b>The enterprise is</b>		<b>% black owned</b>
	<b>The enterprise is</b>		<b>% black woman owned</b>
	Based on the financial statements / management accounts and other information available on the _____ financial year, the income did not exceed R10,000,000.00 (ten million Rand);		
	Please confirm on the table below the B-BBEE level contributor, <b>by ticking the applicable box.</b>		
	<b>Level One</b>	100% black owned (135% B-BBEE procurement recognition)	
	<b>Level Two</b>	More than 51% black owned (125% B-BBEE procurement recognition)	
	<b>Level Four</b>	Less than 51% black owned (100% B-BBEE procurement recognition)	
<b>4.</b>	The entity is an empowering supplier in terms of <b>the dti</b> Codes of Good Practice.		
<b>5.</b>	I know and understand the contents of this affidavit and I have no objection to take the prescribed oath and consider the oath binding on my conscience and on the owners of the enterprise which I represent in this matter.		
<b>6.</b>	The sworn affidavit will be valid for a period of 12 months from the date signed by commissioner.		
<b>Deponent signature:</b>		Commissioner of Oaths stamp	
<b>Date:</b>			
<b>Commissioner of Oaths signature</b>			
<b>Date</b>			



---

**SWORN AFFIDAVIT – B-BBEE QUALIFYING SMALL ENTERPRISE - GENERAL**

---

I, the undersigned,			
Full name			
Surname			
Identity number			
Hereby declare under oath as follows:			
7.	The contents of this statement are to the best of my knowledge a true reflection of the facts.		
8.	I am a member / director / owner of the following enterprise and am duly authorised to act on its behalf:		
	Enterprise legal name		
	Trading name		
	Registration number		
	Enterprise physical address		
	Type of entity (CC, (Pty) Ltd., Sole Proprietor, etc.)		
	Nature of business		
	Definition of "Black People"	<p>As per the Broad-Based Black Economic Empowerment Act 53 of 2003 as Amended by Act No 46 of 2013 "Black People" is a generic term which means Africans, Coloureds and Indians –</p> <p>(a) Who are citizens of the Republic of South Africa by birth or descent; or</p> <p>(b) Who became citizens of the Republic of South Africa by naturalization-</p> <p>i. Before 27 April 1994; or</p> <p>ii. On or after 27 April 1994 and who would have been entitled to acquire citizenship by naturalization prior to that date</p>	
9.	I hereby declare under oath that:		
	The enterprise is	% black owned	As per amended code series 100 of the amended Codes of Good Practice issued under section 9(1) of B-BBEE Act no. 53 of 2003 as amended by Act n. 46 of 2013
	The enterprise is	% black woman owned	
	The enterprise is	% Black designated group owned	
	Based on the financial statements / management accounts and other information available on the latest financial year-end of _____, the annual Total Revenue was between R10,000,000.00 (ten million rands) and R50,000,000 (fifty million rands),		
	Please confirm on the table below the B-BBEE level contributor, <b>by ticking the applicable box.</b>		
	<b>Level One</b>	100% black owned (135% B-BBEE procurement recognition)	
	<b>Level Two</b>	At least 51% black owned (125% B-BBEE procurement recognition)	
10.	I know and understand the contents of this affidavit and I have no objection to take the prescribed oath and consider the oath binding on my conscience and on the owners of the enterprise which I represent in this matter.		
11.	The sworn affidavit will be valid for a period of 12 months from the date signed by commissioner.		
	Deponent signature:		Commissioner of Oaths stamp
	Date:		
	Commissioner of Oaths signature		
	Date		

**10. MBD 6.2. – DECLARATION CERTIFICATE FOR LOCAL PRODUCTION AND CONTENT FOR DESIGNATED SECTORS**
**1. Introduction**

This Municipal Bidding Document (MBD) must form part of all bids invited. It contains general information and serves as a declaration form for local content (local production and local content are used interchangeably).

Before completing this declaration, bidders must study the:

- General Conditions,
- Definitions,
- Directives applicable in respect of Local Content as prescribed in the Preferential Procurement Regulations, 2011; and
- South African Bureau of Standards (SABS) approved technical specification number SATS 1286:2011 (Edition 1)<sup>5</sup> and the Guidance on the Calculation of Local Content together with the Local Content Declaration Templates
  - Annexure C- Local Content Declaration: Summary Schedule,
  - Annexure D- Imported Content Declaration: Supporting Schedule to Annex C and
  - Annexure E- Local Content Declaration: Supporting Schedule to Annex C.

**2. General Conditions**

- 2.1 Preferential Procurement Regulations, 2011 (Regulation 9) makes provision for the promotion of local production and content.
- 2.2 Regulation 9.(1) prescribes that in the case of designated sectors, where in the award of bids local production and content is of critical importance, such bids must be advertised with the specific bidding condition that only locally produced goods, services or works or locally manufactured goods, with a stipulated minimum threshold for local production and content will be considered.
- 2.3 Where necessary, for bids referred to in paragraph 1.2 above, a two stage bidding process may be followed, where the first stage involves a minimum threshold for local production and content and the second stage price and B-BBEE.
- 2.4 A person awarded a contract in relation to a designated sector, may not sub-contract in such a manner that the local production and content of the overall value of the contract is reduced to below the stipulated minimum threshold.
- 2.5 The local content (LC) expressed as a percentage of the bid price must be calculated in accordance with the SABS approved technical specification number SATS 1286: 2011 as follows:

$$LC = [1 - x / y] * 100$$

Where

*x* is the imported content in Rand

*y* is the bid price in Rand excluding value added tax (VAT)

Prices referred to in the determination of *x* must be converted to Rand (ZAR) by using the exchange rate published by the South African Reserve Bank (SARB) at 12:00 on the date of advertisement of the bid as required in paragraph 4.1 below.

- 2.6 A bid may be disqualified if –
- (a) this Declaration Certificate and the Annexure C (Local Content Declaration: Summary Schedule) are not submitted as part of the bid documentation; and
  - (b) the bidder fails to declare that the Local Content Declaration Templates (Annexure C, D and E) have been audited and certified as correct.

<sup>5</sup> The SABS approved technical specification number SATS 1286:2011 is accessible on [http://www.thedti.gov.za/industrial\\_development/ip.jsp](http://www.thedti.gov.za/industrial_development/ip.jsp) at no cost.



**3. Definitions**

- 3.1 **“bid”** includes written price quotations, advertised competitive bids or proposals;
- 3.2 **“bid price”** price offered by the bidder, excluding value added tax (VAT);
- 3.3 **“contract”** means the agreement that results from the acceptance of a bid by an organ of state;
- 3.4 **“designated sector”** means a sector, sub-sector or industry that has been designated by the Department of Trade and Industry in line with national development and industrial policies for local production, where only locally produced services, works or goods or locally manufactured goods meet the stipulated minimum threshold for local production and content;
- 3.5 **“duly sign”** means a Declaration Certificate for Local Content that has been signed by the Chief Financial Officer or other legally responsible person nominated in writing by the Chief Executive, or senior member / person with management responsibility(close corporation, partnership or individual).
- 3.6 **“imported content”** means that portion of the bid price represented by the cost of components, parts or materials which have been or are still to be imported (whether by the supplier or its subcontractors) and which costs are inclusive of the costs abroad (this includes labour and intellectual property costs), plus freight and other direct importation costs, such as landing costs, dock duties, import duty, sales duty or other similar tax or duty at the South African port of entry;
- 3.7 **“local content”** means that portion of the bid price which is not included in the imported content, provided that local manufacture does take place;
- 3.8 **“stipulated minimum threshold”** means that portion of local production and content as determined by the Department of Trade and Industry; and
- 3.9 **“sub-contract”** means the primary contractor’s assigning, leasing, making out work to, or employing another person to support such primary contractor in the execution of part of a project in terms of the contract.

**4. The stipulated minimum threshold(s) for local production and content (refer to Annex A of SATS 1286:2011) for this bid is/are as follows:**

#	Description of services, works or goods	Stipulated minimum threshold as a %
1.	Valves products and actuators	70%

	Description	% Local Content per unit
1.28.	Hydrant Valves	70%
1.29.	Gate Valves:	70%
1.29.1.	Flanged, Hand wheel Operated (Drilled Table D, BS 10)	70%
1.29.2.	Cap Top – Socketed To Suit PVC Pipe	70%
1.29.3.	Cap Top - Plain Ended	70%
1.29.4.	Gate Valves C X C Brass	70%
1.29.5.	Gate Valves F X F Brass	70%
1.30.	Non-Return Valves	70%
1.31.	Ventomat (or Similar) Rbx Air Release Valves and Vacuum Break Valves (Stainless Steel)	70%
1.32.	MUNICIPAL BALL COCKS	70%
1.33.	Ball Valves	70%
1.35.	Brass Taps	70%
1.35.9.	Plastic Hose Bib-Cocks	70%
4.162.	Plastic Taps, Plastic Compression Fittings	70%
4.163.	Stop Taps - 15mm	70%



5. Does any portion of the services, works or goods offered have any imported content?  
(Tick applicable box)

YES		NO	
-----	--	----	--

5.1 If yes, the rate(s) of exchange to be used in this bid to calculate the local content as prescribed in paragraph 1.5 of the general conditions must be the rate(s) published by the SARB for the specific currency at 12:00 on the date of advertisement of the bid.

The relevant rates of exchange information is accessible on [www.reservebank.co.za](http://www.reservebank.co.za).

Indicate the rate(s) of exchange against the appropriate currency in the table below (refer to Annexure A of SATS 1286:2011):

Currency	Rates of exchange
US Dollar	
Pound Sterling	
Euro	
Yen	
Yuan	
Other	

**NB: Bidders must submit proof of the SARB rate (s) of exchange used.**

6. Were the Local Content Declaration Templates (Annexure C, D and E) audited and certified as correct?  
(Tick applicable box)

YES		NO	
-----	--	----	--

6.1 If yes, provide the following particulars:

a) Full name of auditor:	
b) Practice number:	
c) Telephone and cell number:	
d) Email address:	

**(Documentary proof regarding the declaration will, when required, be submitted to the satisfaction of the Accounting Officer)**

7. Where, after the award of a bid, challenges are experienced in meeting the stipulated minimum threshold for local content the dti must be informed accordingly in order for the dti to verify and in consultation with the Accounting Officer provide directives in this regard.

SIGNATURE OF BIDDER(S):			
WITNESS 1:		WITNESS 2:	
DATE:			
ADDRESS:			



**LOCAL CONTENT DECLARATION**

**LOCAL CONTENT DECLARATION BY CHIEF FINANCIAL OFFICER OR OTHER LEGALLY RESPONSIBLE PERSON NOMINATED IN WRITING BY THE CHIEF EXECUTIVE OR SENIOR MEMBER/PERSON WITH MANAGEMENT RESPONSIBILITY (CLOSE CORPORATION, PARTNERSHIP OR INDIVIDUAL)**

**In respect of Tender No. SC1758/2017 issued by Overstrand Municipality**

**NB**

1. The obligation to complete, duly sign and submit this declaration cannot be transferred to an external authorized representative, auditor or any other third party acting on behalf of the bidder.
2. Guidance on the Calculation of Local Content together with Local Content Declaration Templates (Annexure C, D and E) is accessible on [http://www.thedti.gov.za/industrial\\_development/ip.jsp](http://www.thedti.gov.za/industrial_development/ip.jsp). Bidders should first complete Declaration D. After completing Declaration D, bidders should complete Declaration E and then consolidate the information on Declaration C. **Declaration C should be submitted with the bid documentation at the closing date and time of the bid in order to substantiate the declaration made in paragraph (c) below.** Declarations D and E should be kept by the bidders for verification purposes for a period of at least 5 years. The successful bidder is required to continuously update Declarations C, D and E with the actual values for the duration of the contract.

I, the undersigned, \_\_\_\_\_ (full names),

do hereby declare, in my capacity as \_\_\_\_\_,

of \_\_\_\_\_,

(name of bidder entity), the following:

1. The facts contained herein are within my own personal knowledge.
2. I have satisfied myself that
  - a) the goods/services/works to be delivered in terms of the above-specified bid comply with the minimum local content requirements as specified in the bid, and as measured in terms of SATS 1286:2011; and
  - b) the declaration templates have been audited and certified to be correct.
3. The local content percentages (%) indicated below has been calculated using the formula given in clause 3 of SATS 1286:2011, the rates of exchange indicated in paragraph 4.1 above and the information contained in Declaration D and E which has been consolidated in Declaration C;

<b>Bid price (Excluding VAT) (y)</b>	R
<b>Imported content (x), as calculated in terms of SATS 1286:2011</b>	R
<b>Stipulated minimum threshold for local content (paragraph 3 above)</b>	
<b>Local content %, as calculated in terms of SATS 1286:2011</b>	

**If the bid is for more than one product, the local content percentages for each product contained in Declaration C shall be used instead of the table above. The local content percentages for each product has been calculated using the formula given in clause 3 of SATS 1286:2011, the rates of exchange indicated in paragraph 4.1 above and the information contained in Declaration D and E.**

4. I accept that the Municipality has the right to request that the local content be verified in terms of the requirements of SATS 1286:2011.
5. I understand that the awarding of the bid is dependent on the accuracy of the information furnished in this application. I also understand that the submission of incorrect data, or data that are not verifiable as described in SATS 1286:2011, may result in the Municipality imposing any or all of the remedies as provided for in Regulation 13 of the Preferential Procurement Regulations, 2011 promulgated under the Preferential Policy Framework Act (PPPFA), 2000 (Act No. 5 of 2000).

	<b>SIGNATURE</b>	<b>DATE</b>
<b>TENDERER</b>		
<b>WITNESS 1:</b>		
<b>WITNESS 2:</b>		



ANNEXURE C

SATS 1286.2011

Local Content Declaration – Summary Schedule

(C1) Tender No.				
(C2) Tender Description				
(C3) Designated product(s)				
(C4) Tender Authority				
(C5) Name of Tendering Entity				
(C6) Tender Exchange Rate	Currency		Rate	
(C7) Specified local content %				

NOTE: VAT to be excluded from all calculations

Tender Item No's	List of Items	Calculation of local content						Tender summary			
		Tender Price – each	Exempted imported value	Tender value net of exempted imported content	Imported value	Local value	Local content % (per item)	Estimated Tender Quantity	Total tender value	Total exempted imported content	Total imported content
(C8)	(C9)	(C10)	(C11)	(C12)	(C13)	(C14)	(C15)	(C16)	(C17)	(C18)	(C19)
1.28.1	Fire Hydrant Cap top valve multi drilled							20			
1.29.1.	Flanged, Hand wheel Operated (Drilled Table D, BS 10)										
1.29.1.1	150mm							6			
1.29.2.	Cap Top – Socketed To Suit PVC Pipe										
1.29.2.1	63mm							1			
1.29.2.2	75mm							4			
1.29.2.3.	90mm							1			
1.29.2.4.	110mm							5			
1.29.2.5.	160mm							1			
1.29.2.6.	200mm							1			
1.29.2.7.	250mm							1			
1.29.2.8.	315mm							1			



Tender Item No's	List of Items	Calculation of local content						Tender summary			
		Tender Price – each	Exempted imported value	Tender value net of exempted imported content	Imported value	Local value	Local content % (per item)	Estimated Tender Quantity	Total tender value	Total exempted imported content	Total imported content
(C8)	(C9)	(C10)	(C11)	(C12)	(C13)	(C14)	(C15)	(C16)	(C17)	(C18)	(C19)
<b>1.29.3.</b>	<b>Cap Top - Plain Ended</b>										
1.29.3.1.	50mm							16			
1.29.3.2.	75mm							10			
1.29.3.3.	100mm							6			
1.29.3.4.	150mm							3			
1.29.3.5.	200mm							1			
<b>1.29.4.</b>	<b>Gate Valves C X C Brass</b>										
1.29.4.1.	15mm							1			
1.29.4.2.	20mm							1			
1.29.4.3.	25mm							1			
1.29.4.4.	40mm							10			
1.29.4.5.	50mm							1			
<b>1.29.5.</b>	<b>Gate Valves F X F Brass</b>										
1.29.5.1.	15mm							1			
1.29.5.2.	20mm							120			
1.29.5.3.	25mm							10			
1.29.5.4.	40mm							12			
1.29.5.5.	50mm							5			
<b>1.30.</b>	<b>Non-Return Valves</b>										
1.30.1.	63mm							1			
1.30.2.	75mm							1			
1.30.3.	90mm							1			



Tender Item No's	List of Items	Calculation of local content						Tender summary			
		Tender Price – each	Exempted imported value	Tender value net of exempted imported content	Imported value	Local value	Local content % (per item)	Estimated Tender Quantity	Total tender value	Total exempted imported content	Total imported content
(C8)	(C9)	(C10)	(C11)	(C12)	(C13)	(C14)	(C15)	(C16)	(C17)	(C18)	(C19)
1.30.4.	110mm							1			
1.30.5.	160mm							1			
1.30.6.	200mm							1			
1.30.7.	250mm							1			
1.30.8.	315mm							1			
1.31.	<b>Ventomat (or Similar) Rbx Air Release Valves and Vacuum Break Valves (Stainless Steel)</b>										
1.31.1.	28mm							1			
1.31.2.	50mm							1			
1.32.	<b>MUNICIPAL BALL COCKS</b>										
1.32.1.	15mm							1			
1.32.2.	22mm							400			
1.32.3.	28mm							1			
1.33.	<b>Ball Valves</b>										
1.33.1.	<b>Ball Valves MXF Chrome Plated</b>										
1.33.1.1.	20mm							1			
1.33.1.2.	25mm							13			
1.33.1.3.	32mm							1			
1.33.1.4.	40mm							10			
1.33.1.5.	50mm							1			
1.33.1.6.	80mm							1			



Tender Item No's	List of Items	Calculation of local content						Tender summary			
		Tender Price – each	Exempted imported value	Tender value net of exempted imported content	Imported value	Local value	Local content % (per item)	Estimated Tender Quantity	Total tender value	Total exempted imported content	Total imported content
(C8)	(C9)	(C10)	(C11)	(C12)	(C13)	(C14)	(C15)	(C16)	(C17)	(C18)	(C19)
<b>1.33.2.</b>	<b>Ball Valves FXF Chrome Plated</b>										
1.33.2.1.	20mm							90			
1.33.2.2.	25mm							1			
1.33.2.3.	32mm							1			
1.33.2.4.	40mm							10			
1.33.2.5.	50mm							1			
1.33.2.6.	80mm							15			
<b>1.35.</b>	<b>Brass Taps</b>										
<b>1.35.1.</b>	<b>Hose Bib-Cocks</b>										
1.35.1.1.	15mm							80			
1.35.1.2.	20mm							20			
<b>1.35.2.</b>	<b>Stopcocks: C X C</b>										
1.35.2.1.	15mm							150			
1.35.2.2.	20mm							450			
1.35.2.3.	25mm							12			
1.35.2.4.	38mm							6			
1.35.2.5.	42mm							1			
<b>1.35.3.</b>	<b>Stopcocks: Female</b>										
1.35.3.1.	15mm							60			
1.35.3.2.	20mm							2350			
1.35.3.3.	25mm							5			
1.35.3.4.	38mm							1			
1.35.3.5.	42mm							1			



Tender Item No's	List of Items	Calculation of local content						Tender summary			
		Tender Price – each	Exempted imported value	Tender value net of exempted imported content	Imported value	Local value	Local content % (per item)	Estimated Tender Quantity	Total tender value	Total exempted imported content	Total imported content
(C8)	(C9)	(C10)	(C11)	(C12)	(C13)	(C14)	(C15)	(C16)	(C17)	(C18)	(C19)
<b>1.35.4.</b>	<b>Stopcocks: Male</b>										
1.35.4.1.	15mm							1			
1.35.4.2.	20mm							1			
1.35.4.3.	25mm							1			
1.35.4.4.	38mm							1			
1.35.4.5.	42mm							1			
<b>1.35.5</b>	<b>Stop Cocks: Plastic Male Male</b>										
1.35.5.1.	15mm							1			
1.35.5.2.	20mm							1			
<b>1.35.6.</b>	<b>Taps Pushbutton</b>										
1.35.6.1.	15mm							1			
1.35.6.2.	20mm							5			
<b>1.35.7.</b>	<b>Loose Key Bib-Cocks : Male</b>										
1.35.7.1.	20mm							15			
<b>1.35.8.</b>	<b>Loose Key Bib-Cocks : Female Male</b>										
1.35.8.1.	20mm							1			
<b>1.35.9</b>	<b>Plastic Hose Bib-Cocks</b>										
1.35.9.1.	15mm							330			
1.35.9.2.	20mm							1			
<b>4.162.</b>	<b>Plastic Taps, Plastic Compression Fittings</b>										
4.162.1.	Tap Hose Bib Tap20 - 3/4 Hose Union							1			
4.162.2.	Tap 15mm Plain Bib Tap Junior							1			
4.162.3.	Tap 20mm Plain Bib Tap Junior							1			
4.162.4.	Tap 15mm Hose Junior Bib Demand 3/4 Hose Union							1			
4.162.5.	Tap 15mm Plain Junior Bib Demand Tap							1			



Tender Item No's	List of Items	Calculation of local content						Tender summary			
		Tender Price – each	Exempted imported value	Tender value net of exempted imported content	Imported value	Local value	Local content % (per item)	Estimated Tender Quantity	Total tender value	Total exempted imported content	Total imported content
(C8)	(C9)	(C10)	(C11)	(C12)	(C13)	(C14)	(C15)	(C16)	(C17)	(C18)	(C19)
4.162.6.	Tap 20mm Plain Junior Bib Demand Tap							1			
4.163.	<b>Stop Taps - 15mm</b>										
4.163.1.	Tap Stop Tap - Copper X Copper							1			
4.163.2.	Tap Stop Tap - Fusion X Fusion							1			
4.163.3.	Tap Stop Tap - Male X Male							1			
4.163.4.	Tap Stop Tap Demand - Copper X Copper							1			
4.163.5.	Tap Stop Tap Demand - Male X Male							1			
4.163.6.	Tap Hose Bib Tap20 - 3/4 Hose Union							1			
4.163.7.	Tap Stop Tap - Copper X Copper 20mm							1			
4.163.8.	Tap Stop Tap - Male X Male 20mm							1			
4.163.9.	Tap Standpipe Pillar Tap - 1/2 Bottom Inlet							1			
4.163.10	Tap 15mm Hose Bib Tap Junior- 3/4 Hose Union							1			
4.163.11	Tap 20mm Hose Bib Tap Junior- 3/4 Hose Union							1			
4.163.12.	Tap Standpipe Pillar Tap - 3/4 Bottom Inlet							1			
<b>(C20) Total tender value</b>											
<b>(C21) Total Exempt imported content</b>											
<b>(C22) Total Tender value net of exempt imported content</b>											
<b>(C23) Total Imported content</b>											
<b>(C24) Total local content</b>											
<b>(C25) Average local content % of tender</b>											

SIGNATURE OF TENDERER AS PER LOCAL CONTENT DECLARATION

DATE

MUNISIPALITEIT



MUNICIPALITY

**ANNEXURE D**

**SATS 1286.2011**

**Imported Content Declaration – Supporting Schedule to Annexure C**

(D1)	<b>Tender No.</b>				
(D2)	<b>Tender Description</b>				
(D3)	<b>Designated product(s)</b>				
(D4)	<b>Tender Authority</b>				
(D5)	<b>Tendering Entity's Name</b>				
(D6)	<b>Tender Exchange Rate</b>	<b>Currency</b>		<b>Rate</b>	

**NOTE: VAT to be excluded from all calculations**

A. Exempted imported content				Calculation of imported content					
Tender item no's	Description of imported content	Local supplier	Overseas supplier	Foreign currency value as per Commercial Invoice	Tender Exchange Rate	Local value of imports	Freight costs to port of entry	All locally incurred landing costs & duties	Total landed cost
(D7)	(D8)	(D9)	(D10)	(D11)	(D12)	(D13)	(D14)	(D15)	(D16)

Summary	
Tender Quantity	Exempted imported value
(D17)	(D18)

(D19) Total exempt imported value

**This total must correspond with Annex C – C21**

B. Imported directly by the Tenderer				Calculation of imported content					
Tender item no's	Description of imported content	Unit of measure	Overseas supplier	Foreign currency value as per Commercial Invoice	Tender Exchange Rate	Local value of imports	Freight costs to port of entry	All locally incurred landing costs & duties	Total landed cost
(D20)	(D21)	(D22)	(D23)	(D24)	(D25)	(D26)	(D27)	(D28)	(D29)

Summary	
Tender Quantity	Total imported value
(D30)	(D31)

(D32) Total imported value by tenderer

MUNISIPALITEIT



MUNICIPALITY

**ANNEXURE D - Continued**

**SATS 1286.2011**

**Imported Content Declaration – Supporting Schedule to Annexure C**

**NOTE: VAT to be excluded from all calculations**

C. Imported by a 3 <sup>rd</sup> party and supplied to the Tenderer				Calculation of imported content						Summary	
Description of imported content	Unit of measure	Local supplier	Overseas supplier	Foreign currency value as per Commercial Invoice	Tender Exchange Rate	Local value of imports	Freight costs to port of entry	All locally incurred landing costs & duties	Total landed cost	Quantity imported	Total imported value
(D33)	(D34)	(D35)	(D36)	(D37)	(D38)	(D39)	(D40)	(D41)	(D42)	(D43)	(D44)
<b>(D45) Total imported value by 3<sup>rd</sup> party</b>											

D. Other foreign currency payments			Calculation of foreign currency payments		Summary of Payments	
Type of payment	Local supplier making the payment	Overseas beneficiary	Foreign currency value paid	Tender rate of exchange	Local value of payments	
(D46)	(D47)	(D48)	(D49)	(D50)	(D51)	
<b>(D52) Total of foreign currency payments declared by tenderer and/or 3<sup>rd</sup> party</b>						
<b>(D53) Total o imported content and foreign currency payments – (D32), (D45) and (D52) above</b>						

**This total must correspond with Annex C – (C23)**

SIGNATURE OF TENDERER AS PER LOCAL CONTENT DECLARATION

DATE



<b>ANNEX E</b>	<b>SATS 1286.2011</b>
<b>Local content Declaration – Summary Schedule</b>	

<b>(E1) Tender No.</b>		<b>NOTE: VAT to be excluded from all calculations</b>
<b>(E2) Tender Description</b>		
<b>(E3) Designated product(s)</b>		
<b>(E4) Tender Authority</b>		
<b>(E5) Tendering Entity's Name</b>		

LOCAL PRODUCTS (Goods, Services and Works)		
Description of items purchased <i>(E6)</i>	Local suppliers <i>(E7)</i>	Value <i>(E8)</i>
<b>(E9) Total local products (Goods, service and works)</b>		

**(E10) Manpower costs** (Tenderer's own manpower cost)

**(E11) Factory overheads** (Rental, depreciation & amortization, utility costs, consumables, etc.)

**(E12) Administration overheads and mark-up** (Marketing, insurance, financing interest, etc.)

**(E13) Total local content**

**This total must correspond with Annex C – C24**

\_\_\_\_\_  
SIGNATURE OF TENDERER AS PER LOCAL CONTENT DECLARATION

\_\_\_\_\_  
DATE



**11. MBD 8 – DECLARATION OF BIDDER’S PAST SUPPLY CHAIN MANAGEMENT PRACTICES**

1. This Municipal Bidding Document must form part of all bids invited.
2. It serves as a declaration to be used by municipalities and municipal entities in ensuring that when goods and services are being procured, all reasonable steps are taken to combat the abuse of the supply chain management system.
3. The bid of any bidder may be rejected if that bidder, or any of its directors have:
  - 3.1. abused the municipality’s / municipal entity’s supply chain management system or committed any improper conduct in relation to such system;
  - 3.2. been convicted for fraud or corruption during the past five years;
  - 3.3. willfully neglected, reneged on or failed to comply with any government, municipal or other public sector contract during the past five years; or
  - 3.4. been listed in the Register for Tender Defaulters in terms of section 29 of the Prevention and Combating of Corrupt Activities Act (No 12 of 2004).
4. In order to give effect to the above, the following questionnaire must be completed and submitted with the bid.

4.1	Is the bidder or any of its directors listed on the National Treasury’s database as a company or person prohibited from doing business with the public sector? <i>(Companies or persons who are listed on this database were informed in writing of this restriction by the National Treasury after the audi alteram partem rule was applied).</i>	<b>Yes</b>	<b>No</b>
4.1.1	If so, furnish particulars:		
4.2	Is the bidder or any of its directors listed on the Register for Tender Defaulters in terms of section 29 of the Prevention and Combating of Corrupt Activities Act (No 12 of 2004)? <i>(To access this Register enter the National Treasury’s website, <a href="http://www.treasury.gov.za">www.treasury.gov.za</a>, click on the icon “Register for Tender Defaulters” or submit your written request for a hard copy of the Register to facsimile number (012) 3265445).</i>	<b>Yes</b>	<b>No</b>
4.2.1	If so, furnish particulars:		
4.3	Was the bidder or any of its directors convicted by a court of law (including a court of law outside the Republic of South Africa) for fraud or corruption during the past five years?	<b>Yes</b>	<b>No</b>
4.3.1	If so, furnish particulars:		



4.4	Does the bidder or any of its directors owe any municipal rates and taxes or municipal charges to the municipality / municipal entity, or to any other municipality / municipal entity, that is in arrears for more than three months?	<b>Yes</b>	<b>No</b>
4.4.1	If so, furnish particulars:		
4.5	Was any contract between the bidder and the municipality / municipal entity or any other organ of state terminated during the past five years on account of failure to perform on or comply with the contract?	<b>Yes</b>	<b>No</b>
4.5.1	If so, furnish particulars:		

**5. CERTIFICATION**

I, the undersigned (full name), \_\_\_\_\_, certify that the information furnished on this declaration form true and correct.

I accept that, in addition to cancellation of a contract, action may be taken against me should this declaration prove to be false.

SIGNATURE:		NAME (PRINT):	
CAPACITY:		DATE:	
NAME OF FIRM:			



**12. MBD 9 – CERTIFICATE OF INDEPENDENT BID DETERMINATION**

1. This Municipal Bidding Document (MBD) must form part of all bids invited.
2. Section 4 (1) (b) (iii) of the Competition Act No. 89 of 1998, as amended, prohibits an agreement between, or concerted practice by, firms, or a decision by an association of firms, if it is between parties in a horizontal relationship and if it involves collusive bidding (or bid rigging).<sup>6</sup> Collusive bidding is a *per se* prohibition meaning that it cannot be justified under any grounds.
3. Municipal Supply Regulation 38 (1) prescribes that a supply chain management policy must provide measures for the combating of abuse of the supply chain management system, and must enable the accounting officer, among others, to:
  - 3.1. take all reasonable steps to prevent such abuse;
  - 3.2. reject the bid of any bidder if that bidder or any of its directors has abused the supply chain management system of the municipality or municipal entity or has committed any improper conduct in relation to such system; and
  - 3.3. cancel a contract awarded to a person if the person committed any corrupt or fraudulent act during the bidding process or the execution of the contract.
4. This MBD serves as a certificate of declaration that would be used by institutions to ensure that, when bids are considered, reasonable steps are taken to prevent any form of bid-rigging.
5. In order to give effect to the above, the attached Certificate of Bid Determination (MBD 9) must be completed and submitted with the bid:

**CERTIFICATE OF INDEPENDENT BID DETERMINATION:**

In response to the invitation for the bid made by:

**OVERSTRAND MUNICIPALITY**

I, the undersigned, in submitting the accompanying bid, hereby make the following statements that I certify to be true and complete in every respect:

1. I have read and I understand the contents of this Certificate;
2. I understand that the accompanying bid will be disqualified if this Certificate is found not to be true and complete in every respect;
3. I am authorized by the bidder to sign this Certificate, and to submit the accompanying bid, on behalf of the bidder;
4. Each person whose signature appears on the accompanying bid has been authorized by the bidder to determine the terms of, and to sign, the bid, on behalf of the bidder;
5. For the purposes of this Certificate and the accompanying bid, I understand that the word “competitor” shall include any individual or organization, other than the bidder, whether or not affiliated with the bidder, who:
  - 5.1. has been requested to submit a bid in response to this bid invitation;

<sup>6</sup> Bid rigging (or collusive bidding) occurs when businesses, that would otherwise be expected to compete, secretly conspire to raise prices or lower the quality of goods and / or services for purchasers who wish to acquire goods and / or services through a bidding process. Bid rigging is, therefore, an agreement between competitors not to compete.



- 5.2. could potentially submit a bid in response to this bid invitation, based on their qualifications, abilities or experience; and
- 5.3. provides the same goods and services as the bidder and/or is in the same line of business as the bidder
- 6. The bidder has arrived at the accompanying bid independently from, and without consultation, communication, agreement or arrangement with any competitor. However communication between partners in a joint venture or consortium<sup>7</sup> will not be construed as collusive bidding.
- 7. In particular, without limiting the generality of paragraphs 6 above, there has been no consultation, communication, agreement or arrangement with any competitor regarding:
  - 7.1. prices;
  - 7.2. geographical area where product or service will be rendered (market allocation)
  - 7.3. methods, factors or formulas used to calculate prices;
  - 7.4. the intention or decision to submit or not to submit, a bid;
  - 7.5. the submission of a bid which does not meet the specifications and conditions of the bid; or
  - 7.6. bidding with the intention not to win the bid.
- 8. In addition, there have been no consultations, communications, agreements or arrangements with any competitor regarding the quality, quantity, specifications and conditions or delivery particulars of the products or services to which this bid invitation relates.
- 9. The terms of the accompanying bid have not been, and will not be, disclosed by the bidder, directly or indirectly, to any competitor, prior to the date and time of the official bid opening or of the awarding of the contract.
- 10. I am aware that, in addition and without prejudice to any other remedy provided to combat any restrictive practices related to bids and contracts, bids that are suspicious will be reported to the Competition Commission for investigation and possible imposition of administrative penalties in terms of section 59 of the Competition Act No. 89 of 1998 and or may be reported to the National Prosecuting Authority (NPA) for criminal investigation and or may be restricted from conducting business with the public sector for a period not exceeding ten (10) years in terms of the Prevention and Combating of Corrupt Activities Act No. 12 of 2004 or any other applicable legislation.

SIGNATURE		NAME (PRINT)	
CAPACITY		DATE	
NAME OF FIRM			

<sup>7</sup> Joint venture or Consortium means an association of persons for the purpose of combining their expertise, property, capital, efforts, skill and knowledge in an activity for the execution of a contract.



**13. MBD 15 – CERTIFICATE FOR PAYMENT OF MUNICIPAL SERVICES**

**DECLARATION IN TERMS OF PARAGRAPH 38(1)(d)(i) OF THE SUPPLY CHAIN MANAGEMENT POLICY OF THE OVERSTRAND MUNICIPALITY (To be signed in the presence of a Commissioner of Oaths)**

I, \_\_\_\_\_, \_\_\_\_\_ (full name and ID no.), hereby acknowledge that the Municipality may reject the tender of the tenderer if any municipal rates and taxes or municipal service charges owed by the bidder or any of its directors/members/partners to the Overstrand Municipality, or to any other municipality or municipal entity, are in arrears for more than 3 (three) months.

I declare that I am duly authorised to act on behalf of \_\_\_\_\_ (name of the firm) and hereby declare, that to the best of my personal knowledge, neither the firm nor any director/member/partner of said firm is in arrears on any of its municipal accounts with any municipality in the Republic of South Africa, for a period longer than 3 (three) months.

I further hereby certify that the information set out in this schedule and/or attachment(s) hereto is true and correct. The bidder acknowledges that failure to properly and truthfully complete this schedule may result in the tender being disqualified, and/or in the event that the tenderer is successful, the cancellation of the contract.

PHYSICAL BUSINESS ADDRESS(ES) OF THE TENDERER	MUNICIPAL ACCOUNT NUMBER

**Further details of the bidder’s director(s) / shareholder(s) / partner(s) / member(s), etc.:**

Director / partner / member	Physical residential address of the director / partner / member	Municipal account number(s)

**PLEASE NOTE:**

1. Copies of all municipal accounts, not older than 3 months, to be submitted with the bid.
2. If the entity or any of its directors/shareholders/partners/members, etc. rents/leases premises a copy of the rental/lease agreement is to be submitted with this bid.

Signature	Position	Date

<p align="center"><b>COMMISSIONER OF OATHS</b></p> <p>Signed and sworn to before me at _____, on this _____ day of _____ 20__</p> <p>by the deponent, who has acknowledged that he/she knows and understands the contents of this affidavit, it is true and correct to the best of his/her knowledge and that he/she has no objection to taking the prescribed oath, and that the prescribed oath will be binding on his/her conscience.</p> <p><b>COMMISSIONER OF OATHS:-</b></p> <p>Position: _____</p> <p>Address: _____</p> <p>Tel: _____</p>	<p align="center"><b>Apply official stamp of authority on this page:</b></p>
---	--



**14. MBD 16 – KEY PERFORMANCE INDICATORS**

1. KEY PERFORMANCE INDICATORS (KPIs)			
1.1.	Work(s) performed / goods delivered within timeframes specified		
1.2.	Work(s) performed / goods delivered within financial framework specified		
1.3.	Acceptable quality of work(s) performed / goods delivered		
1.4.	OTHER:		
	(a)		
	(b)		
	(c)		
	(d)		
	(e)		
<p>I / We acknowledge that I / we am / are fully acquainted with the abovementioned Key Performance Indicators (KPIs) applicable to this tender / contract as stipulated by the Municipality and that I / we accept these Key Performance Indicators (KPIs) in all respects.</p> <p>I / We furthermore confirm I / we satisfied myself / ourselves as to the corrections and validity of my / our tender: that the price quoted cover all the work / item(s) specified in the tender document and that the price cover all my / our obligations under a resulting contract and that I / we accept that any mistake(s) regarding price and calculations will be at my / our risk.</p>			
SIGNATURE			NAME (PRINT)
CAPACITY			DATE
NAME OF FIRM			
WITNESS 1			WITNESS 2



**15. SECTION 37(2) OF THE OCCUPATIONAL HEALTH AND SAFETY ACT, NO 85 OF 1993**

**INTRODUCTION**

In terms of section 16(1) of the Occupational Health and Safety Act, 1993 (Act 85 of 1993) the Chief Executive Officer is responsible as far as is reasonably practicable to ensure that the duties of his employer as contemplated in the Act are properly discharged. This responsibility is also, in terms of section 37(2) of the Act, extended to include a mandatary that performs work on behalf of the employer on his/her premises.

A “mandatary” is defined in the said Act as: - *“Including an agent, contractor or subcontractor for work, but without derogating from his status in his own right as an employer or user”*

In terms of Section 37(2), read with section 41, of the said Act, it is legally possible for an employer to indemnify himself from this responsibility or liability regarding the actions of the mandatary. Section 37(2) stipulates that there should be a written agreement in place between the employer and the mandatary regarding the arrangements and procedures between them to ensure compliance by the mandatary with the provisions of the Occupational Health and Safety Act, 1993.

By ensuring that there is a written agreement in place, the management of Overstrand Municipality is acting in a responsible manner, so as to ensure that this requirement is indeed being met.

In order to ensure that this written agreement is honoured at all times, regular inspections of work that is in the process of being executed will be conducted and if found not to be in compliance with the said agreement, a notice of non-compliance will be issued. All work will be stopped, reasons for non-compliance must be given including the corrective action that will be taken to rectify the situation must be stipulated.

**COMPENSATION FOR OCCUPATIONAL INJURIES AND DISEASES ACT, 1993 (ACT 130 OF 1993)**

**Overstrand Municipality** has legal duty in terms of Section 89 of the said Act to ensure that all contractors with whom agreements are entered into for the execution of work are registered as employers in accordance with the provisions of this Act and that all the necessary assessments have been paid by the contractor.

In order to enter into this agreement, the following information is needed regarding the above-mentioned:

Contractor’s registration number with the office of the Compensation Commissioner:	
--	--

**NOTE:**  
**A copy of the latest receipt together with a copy of the relevant assessment OR a copy of a valid Letter of Good Standing to be handed in, in this regard.**

PRINT NAME:			
CAPACITY:		Name of firm	
SIGNATURE:		DATE:	



**WRITTEN AGREEMENT**

This is a written agreement between

**OVERSTRAND MUNICIPALITY**

And

\_\_\_\_\_ *(Name of the MANDATARY)*

in terms Section 37(2) of the Occupational Health and Safety Act, 1993 (Act 85 of 1993) as amended.

I, \_\_\_\_\_, representing the MANDATARY do hereby acknowledge that \_\_\_\_\_ *(mandatary)* is an employer in its own right with duties as prescribed in the Occupational Health and Safety Act, 1993 (Act 85 of 1993) as amended and agree to ensure that all work that will be performed, any article or substance that will be produced, processed, used, handled, stored or transported and plant and machinery that will be used, will be done in accordance with the provisions of the said Act.

I furthermore agree to comply with the Health and Safety requirements and to liaise with the Municipality should I, for whatever reason, be unable to perform in terms of this Agreement.

SIGNED ON BEHALF OF MANDATORY			
DATE:		PLACE:	
PRINT NAME:			
CAPACITY:			
SIGNATURE:			

SIGNED ON BEHALF OF THE MUNICIPALITY			
DATE:		PLACE:	
PRINT NAME:			
CAPACITY:			
SIGNATURE:			



**16. INDEMNITY**

Given by (name of company) \_\_\_\_\_  
 of (registered address of company) \_\_\_\_\_  
 a company with limited liability registration number \_\_\_\_\_  
 registered in terms of Laws of the Republic of South Africa (hereinafter the contractor), represented by  
 (name of representative) \_\_\_\_\_  
 in his capacity as (designation) \_\_\_\_\_  
 of the contractor, and duly authorised by a resolution dated \_\_\_\_\_ /20\_\_\_\_\_.

**WHEREAS** the contractor entered into a contract with the municipality dated \_\_\_\_\_ /20\_\_\_\_\_.

**AND WHEREAS** the Municipality requires an indemnity from the contractor.

**NOW THEREFORE** the contractor hereby indemnifies and holds harmless the Municipality in respect of all loss and/or damage that may be incurred or sustained by the contractor by reason of or in any way arising out of or caused by operations that may be carried out by the contractor in connection with the aforementioned contract; and also in respect of all claims that may be instituted against the Municipality in consequence of such operations, by reason of or in any way arising out of any accidents or damage to life or property or any other cause whatsoever including all legal fees and costs that may be incurred by the Municipality in examining, resisting or settling any such claims.

SIGNATURE OF CONTRACTOR:	
DATE:	
SIGNATURE OF WITNESS 1:	
DATE:	
SIGNATURE OF WITNESS 2:	
DATE:	



## **PART B – SPECIFICATIONS AND PRICING**

<b>17. SPECIFICATIONS</b>
---------------------------

**1. Introduction**

The successful bidder / bidders will be expected to supply and deliver plumbing material, plumbing tools & irrigation items to Overstrand Municipality (OM) for the contract period ending 30 June 2020.

**2. Background**

As the current tender is drawing to a close it is necessary to request bidders to tender for the supply and delivery of plumbing material, plumbing tools & irrigation items. It is necessary to understand the following:

- 2.1. Where Brand names are used it is to indicate a quality standard, therefore bidder may offer equal or similar products in line with the tender specifications.
- 2.2. The current tender expires on 30 June 2017.

**3. Scope**

Supply and delivery of plumbing material, plumbing tools & irrigation items to OM for a contract period ending 30 June 2020.

**4. General**

4.1. The submission of a tender signifies complete acceptance of the conditions contained in these instructions and the annexures.

4.2. Together with each tender (compulsory to submit the **original** hard copy) submitted, it is **required** that these calculations (**pricing schedule**) be submitted on a **CD or USB memory stick in a Microsoft Excel spreadsheet**. The Excel pricing schedule format will be available on the Overstrand website, [www.overstrand.gov.za](http://www.overstrand.gov.za)

4.2.1. Should there be any inconsistencies in the pricing between the CD or USB prices and the pricing entered in the tender document itself the hand written price will be deemed to be correct.

4.2.2. Neither the CD nor the USB memory stick will be returned after the tender process is completed

**4.3. Local content**

It is a requirement of this tender that various items adhere to the local content requirement as set out by Department of Trade and Industry – see MBD6.2 for details.

**4.4. Lead Time**

Lead times **must** be indicated on the pricing schedule and delivery **must** take place within the lead times specified, to give effect to the obligations in the agreement.

**4.5. Pricing:**

4.5.1. Prices must include delivery and off-loading at the respective stores mentioned in 4.10 below and must include VAT.

4.5.2. Where the prices of goods are affected by:

4.5.2.1. **Rate of exchange**, (Currency Fluctuations)

4.5.2.1.1. The bidder can use ROE only with CPIX of which CPIX will be applicable on the ROE price as confirmed by the bidder on an annual basis.

4.5.2.1.2. For evaluation and escalation purposes the base rate of exchange, will be the date of advertisement.

SIGNATURE		NAME (PRINT)	
CAPACITY		DATE	
NAME OF FIRM			



**4.5.2.2. Industry fluctuations, (Regulated by SIEFSA, or Manufacturers)**

The bidder will only be allowed escalations once written confirmation is provided to OM prior to implementation. When using Industry fluctuation escalations, no other escalation types will be accepted.

**4.5.2.3. CPIX (Annually from the implementation date)**

The bidder will be allowed to escalate prices on an annual basis from the date of implementation with an average over the past year and not exceeding 10%.

4.5.3. Such variations will only be allowed upon submission date of proof supporting such claims. Non-compliance hereto will be for the suppliers own account.

4.5.4. All price increase formulae must be indicated by the bidder on the pricing schedule. Non-compliance hereto will default to a CPIX escalation

**4.5.5. Escalation – proof of evidence:**

4.5.5.1. All price increases over the next three years (or part thereof) influenced by, ROE, industry / manufacturing and CPIX related escalations, will only be allowed upon submission of proof supporting such claims. These claims must be communicated (in advance) in writing to the OM Supply Chain Management unit, prior to the implementation date. Price increases will only be implemented once written notification and proof of evidence have been received and accepted by the Municipality. Non-compliance herewith will be for the suppliers own account.

4.5.5.2. Prices should be fixed for a period ending 30 June 2020, subject to escalations accepted by OM as stated above. Should excessive increases occur, the municipality will reserve the right to obtain other quotations and/or cancel the contract.

**4.6. Quality and quantities:**

4.6.1. Quality test: The Municipality may from time to time test the quality of the products and non-compliance may result in the termination of the contract. Should the Municipality suffer any losses due to substandard quality products (as agreed to) the supplier will be held responsible. All product items should carry (minimum of one year) guarantees or warranties. Defects will be replaced at the expense of the supplier. The supplier will be responsible to ensure that the products are replaced and delivered.

4.6.2. The quantities as indicated in the pricing schedule are only estimates, which will be used in order to evaluate the bid. The OM will not be bound to the estimated quantities as this will be an “as and when” tender.

4.6.3. OM reserves the right to request samples request bidders to submit samples during the evaluation period if so required.

4.7. Two bidders will be identified for award to ensure that if the first bidder fails to perform according to the tender conditions, the second bidder will be used from which to procure the goods. The first will be held responsible for the cost difference. OM will not be obligated to place orders with the second bidder, when performance of the first bidders is of an acceptable standard.

4.7.1. Notwithstanding the above OM reserves the right to award products / items individually or per category of products / items.

4.8. OM reserves the right to claim any damages caused by the bidder for withdrawal of a bid after the award has taken place. This claim, due to withdrawal, will include administration and advertisement expenses.

4.9. OM reserves the right to make use of other suppliers, where the supplier is in breach of contract regarding delivery lead times and/or when emergencies arise and the supplier does not carry stock. Failing to keep to the agreed delivery times, the supplier will be responsible for the difference in cost, when OM needs to procure from another supplier.

SIGNATURE		NAME (PRINT)	
CAPACITY		DATE	
NAME OF FIRM			



**4.10. Deliveries:**

- 4.10.1. Complete order quantity deliveries is compulsory.
  - 4.10.2. The delivery address will be indicated on the official order as one of the following:
    - 4.10.2.1. Municipal Store, 1 Mussel Road, HERMANUS
    - 4.10.2.2. Municipal Store, 13th Street, KLEINMOND
    - 4.10.2.3. Municipal Store, Voortrekker Road, GANSBAAI
  - 4.10.3. Delivery of products to the designated delivery addresses as indicated above **must** include the off-loading thereof at the supplier's own risk and cost.
  - 4.10.4. Delivery must take place on normal business days between 08h00 and 15h00. (excluding lunch hour 13h00 to 13h45) Non-compliance hereto, could lead to the rejection of the delivery and OM will not be held responsible for any cost incurred.
  - 4.10.5. Bidders must supply and ensure the availability of their own labour for the offloading of the products at the designated Municipal Stores.
- 4.11. Non-compliance with the agreed delivery time, quality, quantity and prices agreed (escalation type indicated) could lead to breach of contract and the supplier will be liable for any expenses incurred as a result thereof.

4.12. **Validity period of tenders:** 150 days.

**4.13. Invoicing and delivery notes**

- 4.13.1. All deliveries should be accompanied by at least a delivery note. OM reserves the right to reject the delivery without a delivery note.
- 4.13.2. Preferably, an invoice or pro-forma invoice must accompany all deliveries.
- 4.13.3. Incorrect invoicing will delay payment and the supplier will be held responsible for correction and resubmission of correct invoices and statements. Settlement discounts on early payments will be reserved if payment is delayed due to incorrect invoicing by the supplier (if applicable and to the agreed settlement discount).

**4.14. Incorrect Information**

- 4.14.1. Where a contract has been awarded on the strength of the information furnished by the bidder, which after the conclusion of the relevant agreement, is proved to have been incorrect, OM reserves the right to cancellation and legal procedures.
- 4.14.2. The Municipality may, in addition to any other legal remedy it may have, recover from the contractor all costs, losses or damages incurred or sustained by the Municipality as a result of the award of the contract due to incorrect information submitted by the bidder.

SIGNATURE		NAME (PRINT)	
CAPACITY		DATE	
NAME OF FIRM			

**PART 2 – PRODUCT SPECIFICATIONS**

**SECTION 1 – uPVC PIPES AND FITTINGS FOR WATER MAINS**

**1. Class 6 – 12 (SABS 966 Part 1) – Refer to Items 1.1 – 1.4 on the pricing schedule.**

1.1. The following information appears on all PVC pressure pipe, manufactured in accordance with the SABS specifications:

- 1.1.1. SABS Mark.
- 1.1.2. SABS Specification number.
- 1.1.3. Nominal pipe size.
- 1.1.4. Pressure class.
- 1.1.5. The designation “PVC-U” or “PVC-M”.
- 1.1.6. Manufacturer’s trade name or trade mark.

**1.2. MINIMUM CONDITIONS**

All pipes for water mains must be approved by SABS and Joint Acceptance Scheme for Water Installation Components J.A.S.W.I.C

**2. PVC Sewer Filters – Refer to item 1.21 on the pricing schedule.**

2.1. Dimensions +/- 420 x 110 x63mm

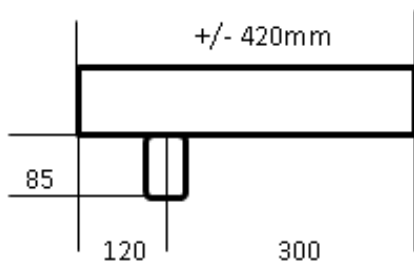

**3. Cast Iron fittings – Refer to items 1.22 – 1.24 on the pricing schedule.**

All Cast Iron fittings to comply with cast iron fittings for UPVC Pipe to EN 12842 Fusion Bonded Thermoplastic coated internally & externally with Plascoat PPA 571 HES 250 uM, complete with EPDM rubber seal ring.

**3.1. Couplings:**

**3.1.1. Cast Iron Short Collar**

- 3.1.1.1. Shall be according to SABS 1223-1985 and bitumen coated according to SABS 1223-1985
- 3.1.1.2. Shall bear the SABS mark and a mark that indicates the nominal diameter
- 3.1.1.3. The quality provided must be equivalent to “PEFCO” short collar joints
- 3.1.1.4. The bolts and nuts shall be stainless steel

**3.2. Universal (Ranger) (Fusion bonded Epoxy Coated)**

- 3.2.1. Shall be according to SABS 719-1971 and BS 534-1990 section 15 and fusion bonded epoxy coated
- 3.2.2. Shall bear the SABS mark and a mark that indicates the nominal diameter
- 3.2.3. The bolts and nuts (**minimum of 4 on ALL sizes**) shall be stainless steel.

SIGNATURE		NAME (PRINT)	
CAPACITY		DATE	
NAME OF FIRM			



3.3. Saddles

3.3.1. Cast Iron

- 3.3.1.1. Are to be manufactured according to JASWIC R44-1992
- 3.3.1.2. All saddles shall indicate the pressure rating and the nominal diameter
- 3.3.1.3. The saddle piece shall be supplied complete with a base sealing gasket and drilled to 22mm, 28mm or 40mm service leading diameter only
- 3.3.1.4. Bolts and nuts composing the saddle shall be stainless steel

3.4. Stainless Steel Repair Clamps (SABS 1808-45)

- 3.4.1. Stainless steel: Type 304 / 316
- 3.4.2. Locking washer plates: Locks into position for easy tightening of nuts
- 3.4.3. Lugs: MIG-welded to receiver bar and fully passitive after welding.
- 3.4.4. Leading edge is rounded to prevent them from catching bolt bars during installation.
- 3.4.5. Shell: 2B finish
- 3.4.6. Bolts: Thread rolled and coated. Bolts MIG-welded to the receiver bar
- 3.4.7. Nuts: Type 304 or Type 316 stainless steel
- 3.4.8. Receiver Bar: TIG-welded to shell to form strong fusion
- 3.4.9. Gasket: Natural rubber formulated for water service.
- 3.4.10. Narrow spacing gridded design;
- 3.4.11. Tapered ends and vulcanized amour plates.
- 3.4.12. Armour: Heavy gauge stainless steel (304 / 316) vulcanized into the gasket at time of moulding, to ensure that it:
- 3.4.13. Fits permanently; Fits perfectly; provides a smooth transition from rubber to metal.
- 3.4.14. **MINIMUM CONDITIONS**  
All fittings for water mains must be approved by **SABS**.

4. Refer to items 1.28 – 1.30 on the Pricing Schedule.

4.1. Fire Hydrant Valves for Waterworks

- 4.1.1. To BS 750 type 2 – Squad model Screw-down type with screwed 2 1/2" round thread outlet Inlet flange to EN 1092-2: 1997 DN 80 (ISO 7005-2, DIN 2501)
- 4.1.2. Universally drilled PN 10/16 and Table D/E – PN 10/16
- 4.1.3. (SANS 1128 1 1977)
- 4.1.4. Coating: Fusion bond epoxy coated

4.2. Gate Valves:

- 4.2.1. To DIN 3352 part 4
- 4.2.2. Face to face dimensions to SABS 664-1989.A
- 4.2.3. Flanges and drilling to ISO 7005-2 (EN 1092-2 (EN 1092-2: 1997, DIN 2501)
- 4.2.4. Materials:
  - 4.2.4.1. Body and bonnet: Ductile iron, GGG-50, to DIN 1693 (BS 2789 grade 500-7)
  - 4.2.4.2. Coating: Fusion bond epoxy coated
  - 4.2.4.3. Stern: Stainless steel, DIN X 20 Cr 13
  - 4.2.4.4. Stern Sealing: NBR wiper ring, 2 NBR O-rings inside and 2 outside a plastic bearing. EPDM rubber manchette
  - 4.2.4.5. Wedges: Ductile iron, GGG-50, core fully encapsulated with EDM rubber with integral wedge nut of dezincification resistant brass, CZ 132 to BS 2874.

SIGNATURE		NAME (PRINT)	
CAPACITY		DATE	
NAME OF FIRM			

- 4.2.4.6. Thrust Collar: Dezincification resistant brass, CZ 132 to BS 2874.
- 4.2.4.7. Bonnet bolts: Stainless steel A2, sealed with hot melt
- 4.2.4.8. Bonnet gasket: EPDM rubber

**4.3. Non-Return Valves**

Non-return valves must be the double door type

**4.4. MINIMUM CONDITIONS**

All valves for water mains must be approved by **SABS**.

**5. Refer to items 1.34 – 1.35 on the pricing schedule.**

**5.1. Dezincification resistant (DZR) brass Compression Fittings**

All DZR compression fittings must be **SABS** and J.A.S.W.I.C approved.

**5.2. Brass Taps**

All brass taps must be **SABS** and J.A.S.W.I.C approved

**5.3. Plastic Taps**

SANS 1024

**5.4. Copper Tubes**

All copper tubes must be **SABS** and J.A.S.W.I.C approved

**6. Refer to tem 1.35.12 On the pricing schedule**

Y In-Line Strainer Brass Valve



**7. Refer to item 1.35.13 – 1.40.9 on the pricing schedule**

**7.1. Brass Tail Pieces**

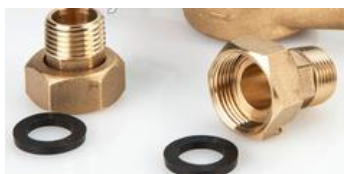

**7.2. HDPE (Plasson) Compression Fittings**

All HDPE compression fittings must be **SABS** and J.A.S.W.I.C approved

**7.3. HDPE Pipes:**

Class 10 (SABS 533, 1982)

**7.4. HDPE (Plasson) SADDLES**

- 7.4.1. Must be manufactured according to a similar quality associated with Plasson fittings in terms of J.A.S.W.I.C R41:1987 with reinforcing ring
- 7.4.2. The female thread on the saddle must be BSP thread
- 7.4.3. Bolts and nuts composing the saddle shall be stainless steel.

SIGNATURE		NAME (PRINT)	
CAPACITY		DATE	
NAME OF FIRM			

7.4.4. MINIMUM CONDITIONS

All fittings must be **SABS** and / or J.A.S.W.I.C approved.

8. Refer to item 1.42 – 1.45 on the pricing schedule.

8.1. Subsoil Poly-Drainage Pipes

- 8.1.1. HDPE subsoil drainage pipe with a corrugated outer wall and a smooth inner wall.
- 8.1.2. The pipe is perforated with either 4 rows of slots, or 2 rows of 8 mm holes providing maximum drainage.

8.2. Storm-water pipes

- 8.2.1. Spigot and socket high-density polyethylene resin structured wall storm-water pipes, 4kn
- 8.2.2. Manufactured in accordance with pr EN 13467- I and form part of ISO 9001:2000 management systems.
- 8.2.3. Stiffness design is according to ISO 9969.
- 8.2.4. Pipe jointing by means of spigot and socket.

8.3. Concrete Storm water or Sewer Pipes

- 8.3.1. (Spigot & Socket Joint) - SANS 677
- 8.3.2. Nominal Diameters Maximum Deflection (ND)
- 8.3.3. The joint uses the rolling rubber ring principal and no lubricant is required.
- 8.3.4. Pipes within this category may be ordered as both storm water culvert (SC) or sewer and irrigation (SI) pipes. SI pipes are hydrostatically tested after manufacturing.

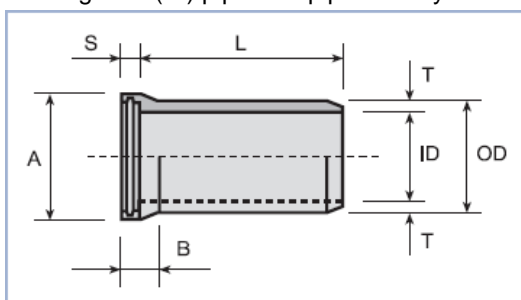

Pipe Class	Nominal Diameter (ND)	Inside Diameter (ID)	Outside Diameter (OD)	Wall Thickness (T)	Outside Diameter (A)	Outside Socket (B)	Inside Socket (S)	Approximate Mass per Meter	Approximate Mass per Pipe	Nominal Length (L)	Proof Load
	mm	mm	mm	mm	mm	mm	mm	Kg/m	Kg/Pipe	m	Kn/M
Class 100	300	298	368	35	464	225	114	110	200	2.44	30
	375	369	445	38	540	235	127	144	263	2.44	38
	450	445	533	44	641	260	127	202	369	2.44	45
	525	514	616	51	730	265	121	259	631	2.44	53
	600	585	699	57	825	300	139	333	812	2.44	60

SIGNATURE		NAME (PRINT)	
CAPACITY		DATE	
NAME OF FIRM			



**SECTION 2 – WATER METERS**

**9. Refer to items 2.1 - 2.9 on the Pricing Schedule.**

**9.1. Standard plastic water meter in box**

- 9.1.1. Meter box to be made from modified polypropylene or plastic with hinged lid containing tamperproof locking mechanism and reading slot.
- 9.1.2. Each meter box must be supplied with a key to open the locking mechanism.
- 9.1.3. Box to house 3-way (open/closed/trickle-flow) ballcock that accepts an optional lock shield facility and sliding coupling.
- 9.1.4. All internal joints to be fusion welded.
- 9.1.5. Meter box inlet and outlet connectors shall be 20mm ( $\frac{3}{4}$ " ) female threaded to accept a suitable 20mm male adaptor.
- 9.1.6. Meter box must be fitted with a 20 mm grooved piston semi-positive displacement sealed, wet dial type meter, fitted with a strainer, with plastic body internal non-return valve and approved pulse rate output of 1:500ml (V110t KSM or similar meter) complying with SANS 1529-1:2006, to **Class C** specifications for horizontal and vertical use.
- 9.1.7. Meter and box to be JASWIC approved.

**9.2. Above Ground Meter Box Complete**

- 9.2.1. Meter box consisting of a pre-plumbed pressure tested meter installation, using 25mm polypropylene internal piping and fusion welded fittings.
- 9.2.2. Meter box to be able to contain the water meter as specified in item B1 or B3.
- 9.2.3. Meter box to be made from modified UV stabilized polypropylene or plastic with hinged lid containing tamperproof locking mechanism, reading slot and base plate.

**9.3. Water Management Device Meter (Kent or Similar)**

- 9.3.1. The **Water Management Devices** when coupled to any standard pulse output water meter by means of a sensor cable must have a certification of conformance in terms of the following specifications.
- 9.3.2. SANS 1529-9:2008 published by the National Regulator for Compulsory Specifications in terms of the Trade Metrology Act ( No 77 of 1973 )
- 9.3.3. The STS Association confirming compliance with IEC 62055-41 IEC 62055-51 and Eskom Reference Q 32DDTEDS/334
- 9.3.4. Independent Communications Authority of South Africa( ICASA ) regulations published in terms of the Telecommunications Act 104 of 1996 and must further support the following functions:

9.3.4.1. Flow limitation

- 9.3.4.1.1. Limitation must be achieved without restricting Flow Rate and must allow full bore flow (full pressure service)
- 9.3.4.1.2. Limitation must be configurable based on volume only, on duration only and a combination of volume and duration.
- 9.3.4.1.3. Limitation must be configurable on a Daily basis with the ability to provide two allocations per day of differing volume, duration or volume and duration configuration.
- 9.3.4.1.4. Limitation must also be configurable on a monthly basis.
- 9.3.4.1.5. Daily limitation from 10 litres per allocation to 50 000 litres per day
- 9.3.4.1.6. A minimum flow rate of 10 litres per minute at a system pressure of 1 bar
- 9.3.4.1.7. Allocation settings must be adjustable in field to higher/lower amounts without the need to replace any parts
- 9.3.4.1.8. The maximum daily volume dispensed amount must be guaranteed (therefore must not be dependent on pressure fluctuations in the network)

SIGNATURE		NAME (PRINT)	
CAPACITY		DATE	
NAME OF FIRM			



- 9.3.4.1.9. Carry-over of unused daily allocation options:
  - 9.3.4.1.9.1. Use it or lose it
  - 9.3.4.1.9.2. Daily carry-over within month, but not monthly carry-over
  - 9.3.4.1.9.3. Daily and monthly carry-over
  - 9.3.4.1.9.4. Carry-over from first allocation to second with and without daily carry-over
- 9.3.4.2. Flow control
  - 9.3.4.2.1. Valve to be reaffirmed daily.
  - 9.3.4.2.2. Valve to flush if obstructed.
  - 9.3.4.2.3. Control to be achieved using a hydraulic diaphragm valve
  - 9.3.4.2.4. Valve should be able to handle a minimum of 50 000 operations
- 9.3.4.3. LCD display indicating
  - 9.3.4.3.1. Remaining allocation in litres.
  - 9.3.4.3.2. The total dispensed to date (in m<sup>3</sup> to a minimum resolution of 0.5 litre)
  - 9.3.4.3.3. The total dispensed to date must clearly differentiate between the multiples and sub multiples of m<sup>3</sup>
  - 9.3.4.3.4. Visible indication of the battery status.
  - 9.3.4.3.5. Visible indication of the valve status
  - 9.3.4.3.6. Visible warning of a potential consumer leak
  - 9.3.4.3.7. Visible Display of the product serial number on demand
  - 9.3.4.3.8. Visible indication of AMR Transmission and confirmation of data received.
- 9.3.4.4. Automated Meter Reading capabilities
  - 9.3.4.4.1. Support of Automatic Meter Reading (AMR) via Radio in the 434 MHz ISM band.
  - 9.3.4.4.2. The WMD must have ICASA approval
  - 9.3.4.4.3. Support walk by, drive by and fixed network Automatic Meter Reading (AMR)
  - 9.3.4.4.4. Provide a typical line of sight RF transmission range of more than 100 m when installed more than 50 cm above ground.
  - 9.3.4.4.5. Support selective parameter updates automatically whilst remotely reading the meters via RF transmission.
  - 9.3.4.4.6. Provide the tamper and valve status in the standard meter reading radio signal
  - 9.3.4.4.7. Support USB, GSM and Wi-Fi down load of meter readings
- 9.3.4.5. Security Features
  - 9.3.4.5.1. Automatic valve closure/shut if the sensor cable is cut, removed or magnetically tampered with
  - 9.3.4.5.2. Serialized and unique security seals which prevent the uncoupling of the sensor cable from the meter pulse output.
  - 9.3.4.5.3. When inspecting the valve there must not be any visible fasteners that form an integral part in the construction / integrity of the valve, the fasteners must be located behind a cover.
  - 9.3.4.5.4. Constructed from materials which have a very limited or no scrap value.
- 9.3.4.6. Additional requirements:-
  - 9.3.4.6.1. Ability to be mounted either horizontally or vertically
  - 9.3.4.6.2. To facilitate infield support both the water meter and the WMD must have an Input and Output coupling of ¾ male BSP. The water meter and WMD must fit into a 115 mm gap.

SIGNATURE		NAME (PRINT)	
CAPACITY		DATE	
NAME OF FIRM			



- 9.3.4.6.3. Compliant to an environmental rating of IP 67, waterproof.
  - 9.3.4.6.4. Service life of at least 10 years with a radio transmission rate of 15 seconds and daily valve switching
  - 9.3.4.6.5. Data logging of at least 3,000 hourly consumption readings and maintain a 12 month record of monthly usage within the WMD data log
  - 9.3.4.6.6. Monitor for and indicate consumer side leaks
  - 9.3.4.6.7. Support reticulation system water balancing
  - 9.3.4.6.8. The WMD must be able to communicate with a field service terminal for in-field interrogation, data downloading and reprogramming (see description below) via radio
  - 9.3.4.6.9. The system installed MUST have necessary NRCS ( SANAS ), ICASA and STS Association approvals ( see above )
  - 9.3.4.6.10. The system must support credit transfer in volume as defined by International spec IEC 62055 – 41 & 51.
  - 9.3.4.6.11. The system must support third party vending of token, and not only a proprietary vending system
  - 9.3.4.6.12. The system must also support bulk water supply
  - 9.3.4.6.13. The device must support an optional remote display which may be made available to the consumer to place inside their home
  - 9.3.4.6.14. Devices must be labelled with a serial number and bar coded .
- 9.3.4.7. Field Support Equipment:-
- 9.3.4.7.1. Each WMD must be capable of communicating with a field service terminal via or short range radio.
  - 9.3.4.7.2. The following features must be supported:
  - 9.3.4.7.3. Field Service Terminal must be a robust, splash and drop proof , hand held device with high quality screen and superior battery performance
  - 9.3.4.7.4. Associated software with various operator levels to manage field usage with confidence and have security restrictions for adjusting of WMD settings
  - 9.3.4.7.5. Adjustable security settings for various operator levels
  - 9.3.4.7.6. Ability to easily configure WMD's to administrator predefined usage settings
  - 9.3.4.7.7. Ability to Interrogate WMD's to upload store information and detailed data for later download to database
  - 9.3.4.7.8. Allow for both automated and manual meter reading
  - 9.3.4.7.9. Run in-field diagnostic functions that fully qualify assess the WMD's functionality without the need for removing it from the installation.
  - 9.3.4.7.10. Provide a graphic representation of the user's consumption in hourly, daily and monthly resolution for the past 150 days.

SIGNATURE		NAME (PRINT)	
CAPACITY		DATE	
NAME OF FIRM			

**9.5. Domestic Water Meters (Volumetric Piston Water Meter)– Kent or Similar**



- 9.5.1. The water meter to be approved by the department of Trade Metrology to SANS 1529-1:2006, to Class C specifications for horizontal and vertical use.
- 9.5.2. Water meters must be
- 9.5.3. Sealed wet dial type meter, fitted with a strainer and non-return valve.
- 9.5.4. Approved pulse output rate of 1:500ml for sizes 15mm and 20mm
- 9.5.5. Meter to be JASWIC approved.

**9.6. Multi-Jet Water Meter (Optima) – Kent or Similar**



- 9.6.1. Type: Fan wheel
- 9.6.2. The water meter to be approved by the department of Trade Metrology to SANS 1529-1:2006, to Class C specifications for horizontal use
- 9.6.3. Integral strainer / removable for cleaning
- 9.6.4. Inlet / outlet ports of measuring cartridge to be evenly spaced around circumference
- 9.6.5. Brass meter body to be manufactured from SABS 200 dezincification resistant base brass alloy
- 9.6.6. Plastic meter body to be manufactured from blended UV stabilized engineering plastic and to comply with SANS 1529-1:2006, to Class C specifications for horizontal use
- 9.6.7. Counter is to be of wet dialled type
- 9.6.8. Lens to be of moulded tampered mineral glass with minimum thickness of 14mm to be convex to magnify meter reading

**9.7. Combination Water Meters - Kent or Similar**



SIGNATURE		NAME (PRINT)	
CAPACITY		DATE	
NAME OF FIRM			

- 9.7.1. In-line combination meter consisting of a vane inferential type water meter, fitted with an integral non-return, pre-calibrated change over valve and an integral volumetric minimum class C bypass meter which is suitable for vertical/horizontal & inclined installation.
- 9.7.2. For logging purposes, both the main and bypass meters are to be fitted with inductive pulse generators.
- 9.7.3. Flanges dual drilled to suit BS10 table D or SANS 1123 table 16 (BS4504)

9.8. **Bulk Water Meter** (50mm, 80mm, 100mm, 150mm)



- 9.8.1. Type: WP Woltmann
- 9.8.2. Operating temperature up to 50deg C and maximum working pressure of 16 Bar, equally accurate in forward and reverse flow.
- 9.8.3. To comply with relevant international quality standards, substantially exceeding ISO4064 / BS5728.
- 9.8.4. Minimum accuracy of Class C
- 9.8.5. IP68 Sealed Counter
- 9.8.6. Dual pulse outputs.
- 9.8.7. Flanges dual drilled to suit BS10 table D or SANS 1123 table 16 (BS4504)

9.9. **In-Line Strainers** (40mm, 50mm,80mm, 100mm, 150mm)



- 9.10.
  - 9.10.1. Manufactured from Cast iron
  - 9.10.2. Heavy duty stainless steel strainer element supported securely top and bottom to stainless steel plate
  - 9.10.3. Strainer element to be removable for cleaning and/or replacement without disturbing flange joints
  - 9.10.4. Maximum working pressure 16 Bar
  - 9.10.5. Maximum water temperature 50 deg C
  - 9.10.6. Flanges dual drilled to suit BS10 table D or SANS 1123 table 16 (BS4504)

9.11. **MINIMUM CONDITIONS**

All water meters to be **SABS** and **J.A.S.W.I.C**, approved

SIGNATURE		NAME (PRINT)	
CAPACITY		DATE	
NAME OF FIRM			



**SECTION 3 – MANHOLE COVERS, ETC.**

**10. Refer to items 3.1 to 3.2 on the pricing schedule.**

**10.1. Polymer concrete products:**

**10.1.1. Type 2A Solid Circular Manhole Cover & Frame**

- 10.1.1.1. Class:Heavy Duty
- 10.1.1.2. Mass Cover:±/ 50kg
- 10.1.1.3. Frame Cover:±/ 30kg
- 10.1.1.4. Force:135kN

**10.1.2. Type 2B Vent Circular Manhole Cover & Frame**

- 10.1.2.1. Class:Heavy Duty
- 10.1.2.2. Mass Cover:±/ 40kg
- 10.1.2.3. Frame Cover:±/ 30kg
- 10.1.2.4. Force:135kN

**10.1.3. Type 3A Bell Toby**

- 10.1.3.1. Class:Heavy Duty
- 10.1.3.2. Mass:±/ 15kg
- 10.1.3.3. Force:±/ 135kN
- 10.1.3.4. Lid secured with 3mm galvanised steel cable

**10.1.4. Type 4A Circular Manhole Cover & Frame**

- 10.1.4.1. Dimensions: 610mm 60mm 700mm
- 10.1.4.2. Inner Diameter: 540mm
- 10.1.4.3. Weight: 46kg
- 10.1.4.4. Strength: 40KN

**10.1.5. Type 5 Rectangular Hydrant Box**

- 10.1.5.1. Class:Medium Duty
- 10.1.5.2. Mass Cover:11kg
- 10.1.5.3. Mass Frame:19kg
- 10.1.5.4. Force:40Kn

**10.1.6. Table 6 Rectangular Gully Grating & Frame**

- 10.1.6.1. Class:Heavy Duty
- 10.1.6.2. Mass Cover:28kg
- 10.1.6.3. Mass Frame:27kg
- 10.1.6.4. Force:135kN

**10.1.7. Type 9D 600 x 450 Rectangular Manhole Cover & Frame**

- 10.1.7.1. Class:Medium Duty
- 10.1.7.2. Mass Cover:34kg
- 10.1.7.3. Mass Frame:18kg
- 10.1.7.4. Force:40kN

SIGNATURE		NAME (PRINT)	
CAPACITY		DATE	
NAME OF FIRM			



**10.1.8. Type 9E 900 x 600 Rectangular Manhole Cover & Frame**

- 10.1.8.1. Class:Light Duty
- 10.1.8.2. Mass Cover:53kg
- 10.1.8.3. Mass Frame:18kg
- 10.1.8.4. Force:7kN

**10.1.9. Type 14B 450 x 450 Square Manhole Cover & Frame**

- 10.1.9.1. Class:Medium Duty
- 10.1.9.2. Mass Cover:20kg
- 10.1.9.3. Mass Frame:12kg
- 10.1.9.4. Force: 40kN

**10.1.10. Type 2A Solid Circular Replacement Cover**

**10.1.11. Type 2B Vent Circular Replacement Cover**

**10.1.12. Table 6 Rectangular Replacement Gully Grating**

**10.1.13. Type 9D 600 x 450 Rectangular Manhole Replacement Cover**

**10.1.14. Type 9E 900 x 600 Rectangular Manhole Replacement Cover**

**10.1.15. Type 14B 450 x 450 Square Manhole Replacement Cover**

**10.1.16. Meter box for rodding eye Type 10**

**10.1.17. MINIMUM CONDITIONS**











- 10.1.17.1. All manhole covers and frames must comply with Sans 1882:2003.
- 10.1.17.2. Must meet load requirements specified in Sans 558 and Sans 1115.

SIGNATURE		NAME (PRINT)	
CAPACITY		DATE	
NAME OF FIRM			

**SECTION 4: SEWER MAINS AND GENERAL PLUMBING SPARES & TOOLS**

**11. Pipes And Fittings For Sewer Mains – Refer to items 4.29 – 4.66 on the pricing schedule**









- 11.1. All pipes and fittings to comply with the SABS Standard Specifications
  - 11.1.1. uPVC Class 51 – normal duty (100kPa pipe stiffness) (SANS 791: 2002)
  - 11.1.2. uPVC Class 34 – heavy duty (300kPa pipe stiffness) (SANS 791: 2002)
  - 11.1.3. U/G Fittings for Sewer – SABS 1601

11.2.	PVC pipe above ground 110mm	
11.3.	PVC pipe underground 110mm	
11.4.	PVC pipe white E-Spec 40mmx6	
11.5.	PVC pipe white E-spec 50mmx6	
11.6.	PVC UG double socket 110mm	
11.7.	PVC UG socket kimberley 110mm	
11.8.	PVC UG single socket 110mm	
11.9.	PVC UG ribbed bend 87.5', inspection eye 110mm,	
11.10.	PVC UG ribbed bend 22.5', 110mm,	
11.11.	PVC UG bend 135', 110mm	









SIGNATURE		NAME (PRINT)	
CAPACITY		DATE	
NAME OF FIRM			

11.12.	PVC UG bend 135', inspection eye 110mm	
11.13.	PVC UG bend 90' 110mm	
11.14.	PVC UG ribbed R/H junction 45°, inspection eye 110mm,	
11.15.	PVC UG ribbed L/H junction 45°, inspection eye, 110mm,	
11.16.	PVC UG ribbed junction 45' 110mm	
11.17.	PVC UG inspection pipe, 110mm	
11.18.	PVC UG junction 45°, 110mm,	
11.19.	PVC UG junction 45°, R/H, inspection eye, 110mm	
11.20.	PVC UG junction 45°, L/H, inspection eye, 110mm	
11.21.	PVC UG junction 90°, 110mm	
11.22.	PVC UG junction 45°	

SIGNATURE		NAME (PRINT)	
CAPACITY		DATE	
NAME OF FIRM			



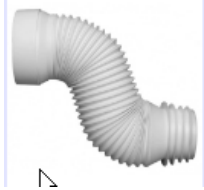

11.23.	PVC UG adaptor PVC/EW female, 110mm,	
11.24.	PVC UG adaptor PVC/EW male, 110mm,	
11.25.	PVC rodding eye 45 DEG X 110mm	
11.26.	PVC stop end 110mm female	
11.27.	PVC stop end 110mm male	
11.28.	PVC gully head & grate, 150mm,	
11.29.	PVC junction 95° double reducing plain, 110 x 50mm	
11.30.	PVC junction 95° double reducing, INSPEction eye, 110 x 50mm	
11.31.	PVC junction 95° single reducing plain, 110 x 50mm	

SIGNATURE		NAME (PRINT)	
CAPACITY		DATE	
NAME OF FIRM			

11.32.	PVC junction 95° single reducing, inspection eye heel, 110 x 50mm	
11.33.	PVC bend 90° plain, 110mm	
11.34.	PVC bend bend 90° inspection eye heel,	
11.35.	PVC bend vent horn inspection eye heel 110mm	
11.36.	PVC pan connector Foxyfit	
11.37.	PVC pan connector straight collar 110	
11.38.	PVC pan connector: Hepworth flexible pan connector	
11.39.	PVC pan Kwickpan connector,	

SIGNATURE		NAME (PRINT)	
CAPACITY		DATE	
NAME OF FIRM			











**SECTION 5 - NON STOCK**

12. PLUMBING, PLUMBINGTOOLS & IRRIGATION ITEMS		
12.1.	Ball float plas/orange 110x8mm	
12.2.	Basin plastic Christy + bracket	
12.3.	Basin: Beta Basin Flair Commercial	 Flair Wall-hung basin
12.4.	Basinwaste 32 X 85 unslotted	
12.5.	Bath sink waste with plug	
12.6.	Bolt set FIXG: 8448ZO #1500212	
12.7.	Chain basin W/STAY CP	
12.8.	Cistern Dutton FP16A Elf mechanism	













SIGNATURE		NAME (PRINT)	
CAPACITY		DATE	
NAME OF FIRM			

12.9.	Cistern inside Beta LL FP15C	
12.10.	Cistern outlet 1 3/4 CP hand	
12.11.	Cistern white Elf LL 9L W/ball	
12.12.	Flexible braided connector	
12.13.	Flush: MW2 dual flush EXT2" + BIBO adapter	
12.14.	Flush: Dutton FP10F supra flush valve (or compatible)	
12.15.	Geyser element spiral Incalloy 3KW	
12.16.	Geyser gasket flange MK2 FLG337	
12.17.	Geyser THERMOSTST KWIKTHERM 11 20AMPS TH208	
12.18.	Head part Start type 15MM	





SIGNATURE		NAME (PRINT)	
CAPACITY		DATE	
NAME OF FIRM			

12.19.	Head Part: S-KM9.201B Head Part CP PushtaP	
12.20.	Hose Clamp Galv G32W 14 – 27MM	
12.21.	Inlet Dutton FP3 Kleenflo Side Inlet (Or Compatable)	
12.22.	Insert FOR Cobra Pipe 15MM	
12.23.	Insert FOR Cobra Pipe 22MM	
12.24.	Nut: Brass Backnut 15MM	
12.25.	Pan Easy Flush 2.5L capacity	
12.26.	Pan Vaal toilet suite Hibiscus	
12.27.	Pan White Protea low level Keradn	
<b>WASTE FITTINGS</b>		
12.28.	PVC waste access cap 1 1/4 BSP	
12.29.	PVC waste access cap 1 1/5 BSP	
12.30.	PVC watsse stopend female 40mm	
12.31.	PVC watsse stopend female 50mm	













SIGNATURE		NAME (PRINT)	
CAPACITY		DATE	
NAME OF FIRM			

12.32.	PVC wase reducer socket 50mm x 40mm	
12.33.	PVC waste socket 40mm	
12.34.	PVC waste socket 50mm	
12.35.	PVC wase strap on boss 110mm x 50mm	
12.36.	PVC HOIDER BAT or HILTI NAIL 40mm	
12.37.	PVC holder bat or hilti nail 50mm	
12.38.	PVC waste junction plain 40mm x 87.5'	
12.39.	PVC waste junction plain 50mm x 87.5'	
12.40.	PVC waste junction inspection 40mm x 87.5'	
12.41.	PVC waste junction inspection 50mm x 87.5'	
12.42.	PVC waste junction plain 40mm x 135' or 45'	
12.43.	PVC waste junction plain 50mm x 135' or 45'	
12.44.	PVC waste junction inspection 40mm x 135' or 45'	
12.45.	PVC waste junction inspection 50mm x 135' or 45'	
12.46.	PVC waste bend 40mm x 135' or 45'	
12.47.	PVC waste bend 50mm x 135' or 45'	
12.48.	PVC waste bend inspection 40mm x 135' or 45'	
12.49.	PVC waste bend inspection 50mm x 135 or 45'	
12.50.	PVC waste short bend 40mm x 135' or 45'	
12.51.	PVC waste short bend 50mm x 135' or 45'	
12.52.	PVC waste short bend inspection 40mm x 135' or 45'	
12.53.	PVC waste short bend inspection 50mm x 135 or 45'	









SIGNATURE		NAME (PRINT)	
CAPACITY		DATE	
NAME OF FIRM			

12.54.	PVC waste bend plain 40mm x 90'	
12.55.	PVC waste bend plain 50mm x 90'	
12.56.	PVC waste bend inspection 40mm x 90'	
12.57.	PVC waste bend inspection 50mm x 90'	
12.58.	PVC waste short bend plain 40mm x 90'	
12.59.	PVC waste short bend plain 50mm x 90'	
12.60.	PVC waste short bend inspection 40mm x 90'	
12.61.	PVC waste short bend inspection 50mm x 90'	
12.62.	PVC vent valve two way 50mm	
12.63.	PVC vent valve one way 50mm	
12.64.	PVC double socket 50	
12.65.	Rubber: bung rubber for flush pipe	
12.66.	Rubber: closet cone black / white PVC.	
12.67.	Rubber: closet rubber bung	
12.68.	Shower head AQUA Shell (or similar approved)	
12.69.	Standpipe Polyprop 15mm with wallplate elbow 950	
12.70.	Tap mixer: Aspen Lite wall sink mixer	

SIGNATURE		NAME (PRINT)	
CAPACITY		DATE	
NAME OF FIRM			

12.71.	Tap mixer: sink mixer solo	
12.72.	Tap pillar 1/2 CP	
12.73.	Tap stopcock under wall 15mm	
12.74.	Tap: KM2.302-15 Pushbutton S/TAP 15	
12.75.	Toilet seat dutton Elf 82 or similar approved	
12.76.	Toilet seat white wooden seat	
12.77.	Trap: PVC basin p - trap 32mm	
12.78.	Trap: PVC basin p – trap 40mm	
12.79.	Trap: PVC bottle trap 40 x 40mm	
12.80.	Trap: PVC double bowl sink combo trap	
12.81.	Vacuum Breaker 20mm CXC Hi-Flo	
12.82.	Valve: C- FM 8.30 piston toilet valve	
12.83.	Valve: handle or arm beta valve	

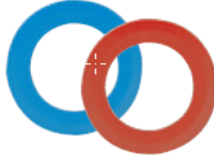
SIGNATURE		NAME (PRINT)	
CAPACITY		DATE	
NAME OF FIRM			

12.84.	Valve: hi-flo multi valve 400KP OR 600KP	
12.85.	Washer conical for 40mm waste trap	
12.86.	Washer for P-trap 32mm	
12.87.	Washer for P-trap 40mm	
12.88.	Washer: fibre washer 16x24x2mm	
12.89.	Washer: fibre washer 24.35x29x1.66mm	
12.90.	Waste basin W/P brass -32	
12.91.	Wax bowl ring white	
<b>SPEED FITTING PLUMBING FITTINGS (OR COMPATIBLE)</b>		
12.92.	<b>'O' ring (replacement)</b> part no. size mm 15EPR 15 22EPR 22 28EPR 28	
	<b>Collet cover</b>	
12.93.	PM1915R 15mm	
12.94.	PM1915B 15mm	
12.95.	PM1922R 22mm	
12.96.	PM1922B 22mm	
	<b>Collet locking clip</b>	
12.97.	CM1815R 15mm	
12.98.	CM1815B 15mm	
12.99.	CM1815W 15mm	
12.100.	CM1822R 22mm	
12.101.	CM1822B 22mm	
12.102.	CM1822W 22mm	

SIGNATURE		NAME (PRINT)	
CAPACITY		DATE	
NAME OF FIRM			

	<b>Collets (replacement)</b>	
12.103.	PXC15 15mm	
12.104.	PXC22 22mm	
12.105.	PXC28 28mm	
12.106.	<b>Connector conversion</b> NC471 15MM X 1/2" ID(connects imperial to metric pipe)	
	<b>Connector equal straight</b>	
12.107.	PEM0415W 15MM	
12.108.	PEM0422W 22MM	
12.109.	PEM0428W 28MM	
12.110.	<b>Connector reducing straight -</b> PEM202215W 22mm X 15mm	
12.111.	<b>Connector slip</b> CM-SC-15S 15mm	
12.112.	<b>Coupler male - straight</b> NC2556 15MM X 1/2" NC2557 22MM X 3/4"	
	<b>Elbow equal</b>	
12.113.	PEM0315W 15MM	
12.114.	PEM0322W 22MM	
12.115.	PEM0328W 28MM	
12.116.	<b>Elbow reducing</b> PEM212215W 22mm X 15mm	
	<b>Elbow stem (swivel action)</b>	
12.117.	PEM221515W 15mm X 15mm	
12.118.	PEM222222W 22mm X 22mm	
12.119.	<b>Elbow wall plate</b> 15PWB 15MM X 1/2"	
	<b>Insert pipe super seal insert</b>	
12.120.	STS15 15mm	
12.121.	STS22 22mm	
12.122.	STS28 28mm	
	<b>Insert standard pipe insert</b> must be used when connecting speedfit pipe with compression - (CONEX) FITTINGS.	
12.123.	TSM15N 15mm	
12.124.	TSM22N 22mm	
12.125.	TSM28N 28mm	









SIGNATURE		NAME (PRINT)	
CAPACITY		DATE	
NAME OF FIRM			

	<b>Pipe barrier speedpex (straight lengths)</b>	 <p>Speedpex Barrier Pipe (Straight Lengths)</p>
12.126.	15BPEX-20X2L 15mm X 2	
12.127.	15BPEX-20X5L 15mm X 5	
12.128.	22BPEX-20X2L 22mm X 2	
12.129.	22BPEX-20X5L 22mm X 5	
12.130.	28BPEX-10X6L 28mm X 6	
	<b>Pipe barrier speedpex (coils)</b>	
12.131.	15BPEX-50C 15mmX 50m	
12.132.	22BPEX-50C 22mm X 50m	
	<b>Reducer – stem</b>	
12.133.	PEM062215W 22mm X 15mm	
12.134.	PEM062815W 28mm X 15mm	
12.135.	PEM062822W 28mm X 22mm	
	<b>Speedfit X hand tighten nut 300mm long</b>	
12.136.	PFLX15 15MM X ½"	
12.137.	PFLX16 15MM X ¾"	
12.138.	PFLX22 22MM X ¾"	
	<b>500mm long</b>	
12.139.	PFLX18 15MM X ½"	
12.140.	PFLX19 22MM X ¾"	
12.141.	WFLX20 15MM X ¾"	
	<b>Speedfit X hand tighten nut with service valve 300mm long</b>	
12.142.	PFLX37-H 15MM X ½"	
12.143.	PFLX39-H 22MM X ¾"	
	<b>Springs bending</b>	
12.144.	SFA-IBS15 15mm INTERNAL	
12.145.	SFA-IBS22 22mm INTERNAL	
12.146.	SFA-EBS15 15mm EXTERNAL	
	<b>Stop end</b>	
12.147.	PSE4615W 15MM	
12.148.	PSE4622W 22MM	
12.149.	PSE4628W 28MM	
	<b>Tap connector female - coupler</b>	
12.150.	PSE3201W 15MM X ½"	
12.151.	PSE3203W 15MM X ¾"	
12.152.	PSE3202W 22MM X ¾"	
	<b>Tap emergency shut off</b>	
12.153.	15ESOT 15mm	

SIGNATURE		NAME (PRINT)	
CAPACITY		DATE	
NAME OF FIRM			

	<b>Tap washing machine</b>	
12.154.	15APT 15MM X 3/4"	
	<b>Tee equal</b>	
12.155.	PEM0215W 15MM	
12.156.	PEM0222W 22MM	
12.157.	PEM0228W 28MM	
	<b>Tee reducing</b>	
12.158.	PEM3022AW 22mm X 22mm X 15mm	
12.159.	PEM3022BW 22mm X 15mm X 15mm	
12.160.	PEM3022CW 15mm X 15mm X 22mm	
12.161.	PEM3022DW 22mm X 15mm X 22mm	
12.162.	PEM3028AW 28mm X 28mm X 22mm	
12.163.	PEM3028BW 28mm X 22mm X 22mm	
12.164.	PEM3028DW 28mm X 22mm X 28mm	
12.165.	PEM302815AW 28mm X 28mm X 15mm	
	<b>Tee stem (swivel action)</b>	
12.166.	PEM532215W 22 X 22 X 15	
	<b>Valve service valve with handle</b>	
12.167.	15SV-H 15mm	 vice
12.168.	22SV-H 22mm	
	<b>Valve stop (65° maximum)</b>	
12.169.	15STV 15mm	 im
12.170.	22STV 22mm	
	<b>Washer thread (replacement)</b>	
12.171.	1/2EPW 1/2"	
12.172.	3/4EPW 3/4"	
<b>PLASTIC TAPS, PLASTIC COMPRESSION FITTINGS</b>		
12.173.	Tap hose bib tap 20 - 3/4 hose union	
12.174.	TAP 15mm plain bib tap junior	





SIGNATURE		NAME (PRINT)	
CAPACITY		DATE	
NAME OF FIRM			

12.175.	TAP 20mm plain bib tap junior	
12.176.	TAP 15MM hose junior bib demand 3/4 hose union	
12.177.	TAP 15mm plain junior bib demand tap	
12.178.	TAP 20mm plain junior bib demand tap	
<b>STOP TAPS - 15MM</b>		
12.179.	Tap stop tap - copper x copper	
12.180.	Tap stop tap - fusion x fusion	
12.181.	Tap stop tap - male x male	
12.182.	Tap stop tap demand - copper x copper	
12.183.	Tap stop tap demand - male x male	
12.184.	Tap hose bib tap 20 - 3/4 hose union	











SIGNATURE		NAME (PRINT)	
CAPACITY		DATE	
NAME OF FIRM			

12.185.	Tap stop tap - copper x copper	
12.186.	Tap stop tap - male x male	
12.187.	Tap standpipe pillar tap - 1/2 bottom inlet	
12.188.	Tap 15mm hose bib tap junior- 3/4 hose union	
12.189.	Tap 20mm hose bib tap junior- 3/4 hose union	
12.190.	Tap standpipe pillar tap - 3/4 bottom inlet	
<b>COMPRESSION FITTINGS 15MM</b>		
12.191.	Cap nut 15mm	
12.192.	Copper x stop-end	
12.193.	Coupling copper x 20mm male coupler	
12.194.	Coupling copper x copper coupler	
12.195.	Coupling copper x copper slip coupler	
12.196.	Coupling copper x female coupler	
12.197.	Coupling copper x male coupler	

SIGNATURE		NAME (PRINT)	
CAPACITY		DATE	
NAME OF FIRM			

12.198.	Elbow 90 degree copper x 20mm male	
12.199.	Elbow 90 degree copper x copper	
12.200.	Elbow 90 degree copper x female	
12.201.	Elbow 90 degree copper x male	
12.202.	Elbow 90 degree wall-plate	
12.203.	Reducer 20 x 15	
12.204.	Tee copper x copper x copper	
12.205.	Tee copper x female x copper	
<b>CISTERN SPARES</b>		
12.206.	VALVE ARM 120MM	
12.207.	VALVE ARM 162MM	
12.208.	VALVE ARM 194MM	
12.209.	VALVE ARM 267MM	
<b>TOOLS</b>		
12.210.	Ratchet Spanner Set 15mm – 24mm	
12.211.	250mm Pipe Wrench	
12.212.	350mm Pipe Wrench	
12.213.	450mm Pipe Wrench	
12.214.	600mm Pipe Wrench	
12.215.	900mm Pipe Wrench	
12.216.	Red knob professional hacksaw	
12.217.	Hammer: 450mm ball pein	

SIGNATURE		NAME (PRINT)	
CAPACITY		DATE	
NAME OF FIRM			

12.218.	Club Hammer 1.8 Kg Fibre Handle	
12.219.	Pliers: 250mm Water Pump	
12.220.	Pliers: 300mm Water Pump	
12.221.	Pliers: 250mm Fencing	
12.222.	Adjustable Wrench: 200mm	
12.223.	Adjustable Wrench: 250mm	
12.224.	Adjustable Wrench: 300mm	
12.225.	Measuring Tape; 10m Stanley Or Similar Approved (where brand names are mentioned it is only to show a quality standard)	
12.226.	Hatchet: 0.9kg poly handle Lasher or similar approved	
12.227.	Chisel: 300mmx25mm	
12.228.	Hammer: slegde hammer 3.6kg	
12.229.	Spirit level: 600mm	
12.230.	Pvc pipe cutter	
12.231.	Tube cutter: 6 - 42mm	

SIGNATURE		NAME (PRINT)	
CAPACITY		DATE	
NAME OF FIRM			

IRRIGATION		
COMPRESSION FITTINGS		
12.232.	<b>ELBOW MALE COMBINATION (P X MI)</b> FF 1190 - 13MM X 15MM ½" BSP FF 1015 - 15MM X 15MM ½" BSP FF 1192 - 15MM X 20MM ¾" BSP FF 1016 - 20MM X 20MM ¾" BSP FF 1017 - 20MM X 15MM ½" BSP FF 1096 - 25MM X 15MM ½" BSP FF 1100 - 25MM X 20MM ¾" BSP FF 1350 - 25MM X 25MM 1" BSP	
12.233.	<b>ELBOW REDUCING</b> FF 1256 - 20MM X 15MM	
12.234.	<b>ELBOWS</b> FF 1012 - 13MM FF 1013 - 15MM FF 1014 - 20MM FF 1060 - 25MM	
12.235.	<b>ELBOWS FEMALE COMBINATION (P X FI)</b> FF 2220 - 15MM X 15MM ½" BSP FF 2240 - 20MM X 15MM ½" BSP FF 2250 - 20MM X 20MM ¾" BSP FF 2260 - 25MM X 15MM ½" BSP FF 2270 - 25MM X 20MM ¾" BSP	
12.236.	<b>END PLUGS</b> FF 1018 - 13MM FF 1019 - 15MM FF 1020 - 20MM FF 1030 - 25MM	
12.237.	<b>MALE ADAPTORS (P X MI)</b> FF 1021 - 15MM X 15MM ½" BSP FF 1032 - 15MM X 20MM ¾" BSP FF 1033 - 20MM X 15MM ½" BSP FF 1022 - 20MM X 20MM ¾" BSP FF 1034 - 20MM X 25MM 1" BSP FF 1036 - 25MM X 15MM ½" BSP FF 1037 - 25MM X 20MM ¾" BSP FF 1035 - 25MM X 25MM 1" BSP	
12.238.	<b>REDUCERS</b> FF 1004 - 15MM X 13MM FF 1120 - 20MM X 13MM FF 1005 - 20MM X 15MM FF 1110 - 25MM X 15MM FF 1045 - 25MM X 20MM	

SIGNATURE		NAME (PRINT)	
CAPACITY		DATE	
NAME OF FIRM			

12.239.	<b>TEES (EQUAL)</b> FF 1006 - 13MM FF 1007 - 15MM FF 1008 - 20MM FF 1050 - 25MM	
12.240.	<b>TEES FEMALE COMBINATION (P X FI)</b> FF 2130 - 20MM X 15MM 1/2" BSP FF 2140 - 20MM X 20MM 3/4" BSP FF 2150 - 25MM X 15MM 1/2" BSP FF 2160 - 25MM X 20MM 3/4" BSP	
12.241.	<b>TEES MALE COMBINATION (P X MI)</b> FF 1180 - 13MM X 15MM 1/2" BSP FF 1009 - 15MM X 15MM 1/2" BSP FF 1182 - 15MM X 20MM 3/4" BSP FF 1010 - 20MM X 20MM 3/4" BSP FF 1011 - 20MM X 15MM 1/2" BSP FF 1080 - 25MM X 15MM 1/2" BSP FF 1089 - 25MM X 20MM 3/4" BSP FF 1300 - 25MM X 25MM 1" BSP	
12.242.	<b>TEES REDUCING</b> FF 1028 - 15MM X 13MM FF 1024 - 20MM X 13MM FF 1025 - 20MM X 15MM FF 1070 - 25MM X 15MM FF 1105 - 25MM X 20MM	
12.243.	<b>SNAP-ON / FULL FLOW HOSE CONNECTORS</b> SB 350 - 13MM SB 360 - 15MM SB 370 - 20MM	
12.244.	<b>FLOW CONTROLS</b> FF 1140 - 13MM FF 1150 - 15MM FF 1160 - 20MM	
12.245.	<b>REDUCING BUSH</b> REDUCING BUSH (15MM-20MM) 1/2" X 3/4" BSP REDUCING BUSH (25MM-15MM) 1" X 1/2" BSP REDUCING BUSH (25MM-20MM) 1" X 3/4" BSP REDUCING BUSH (32MM-15MM) 1 1/4" X 1/2" BSP REDUCING BUSH (32MM-20MM) 1 1/4" X 3/4" BSP REDUCING BUSH (32MM-25MM) 1 1/4" X 1" BSP REDUCING BUSH (40MM-15MM) 1 1/2" X 1/2" BSP REDUCING BUSH (40MM-20MM) 1 1/2" X 3/4" BSP REDUCING BUSH (40MM-25MM) 1 1/2" X 1" BSP REDUCING BUSH (40MM-32MM) 1 1/2" X 1 1/4" BSP REDUCING BUSH (50MM-20MM) 2" X 3/4" BSP REDUCING BUSH (50MM-20MM) 2" X 1" BSP REDUCING BUSH (50MM-32MM) 2" X 1 1/4" BSP REDUCING BUSH (50MM-40MM) 2" X 1 1/2" BSP	
12.246.	<b>HEX REDUCING NIPPLE</b> (20MM - 15MM) 3/4" X 1/2" BSP (25MM - 15MM) 1" X 1/2" BSP (25MM - 20MM) 1" X 3/4" BSP	

SIGNATURE		NAME (PRINT)	
CAPACITY		DATE	
NAME OF FIRM			

12.247.	<b>HEX NIPPLE</b> 15MM ½" BSP 20MM ¾" BSP 25MM 1" BSP 32MM 1¼" BSP 40MM 1½" BSP 50MM 2" BSP	
12.248.	<b>EMJAY SOCKET</b> 15MM ½" BSP (15MM) 20MM ¾" BSP (20MM) 25MM 1" BSP (25MM)	
12.249.	<b>CONNECTOR</b> 15mm 20mm 25mm 32mm 40mm 50mm	
12.250.	<b>EQUAL TEEPIECE</b> 15mm 20mm 25mm 32mm 40mm 50mm	
12.251.	<b>ELBOW</b> 15mm 20mm 25mm 32mm 40mm 50mm	
12.252.	<b>MALE COMBINATION TEEPIECE (POP-UP TEE PIECE)</b> 15mm x 15mm ½" BSP 20mm x 15mm ½" BSP 20mm x 20mm ¾" BSP 25mm x 15mm ½" BSP 25mm x 20mm ¾" BSP 25mm x 25mm 1" BSP 32mm x 15mm ½" BSP 32mm x 20mm ¾" BSP 32mm x 25mm 1" BSP 32mm x 32mm 1¼" BSP	
12.253.	<b>MALE COMBINATION ELBOW (POP-UP ELBOW)</b> 15mm x 15mm ½" BSP 20mm x 15mm ½" BSP 20mm x 20mm ¾" BSP 25mm x 15mm ½" BSP 25mm x 20mm ¾" BSP 25mm x 25mm 1" BSP 32mm x 32mm 1¼" BSP	

SIGNATURE		NAME (PRINT)	
CAPACITY		DATE	
NAME OF FIRM			

12.254.	<b>FEMALE COMBINATION ELBOW</b> 15mm x 15MM ½" BSP 20mm x 15MM ½" BSP 20mm x 20MM ¾" BSP 25mm x 15MM ½" BSP 25mm x 20MM ¾" BSP 25mm x 25MM 1" BSP 40mm x 40MM 1½" BSP 50mm x 50MM 2" BSP	
12.255.	<b>MALE ADAPTOR (P X MI)</b> 5mm x ½" BSP 15mm x ¾" BSP 20mm x ¾" BSP 20mm x 1" BSP 25mm x 1" BSP 25mm x 1¼" BSP 32mm x 1¼" BSP	
12.256.	MANIFOLD 2 OUTLET MANIFOLD 3 OUTLET MANIFOLD 4 OUTLET	
12.257.	<b>PVC GREEN FLEXIBLE TUBING</b> 4MM X 100M – GREEN 4MM X 600MM - GREEN	
12.258.	<b>PIPE POLY NON SABS</b> 15MM CLASS 3 20MM CLASS 3 25MM CLASS 3 32MM CLASS 3 40MM CLASS 3 50MM CLASS 3	
12.259.	<b>PIPE POLY NON SABS</b> 15MM CLASS 6 20MM CLASS 6 25MM CLASS 6 32MM CLASS 6 40MM CLASS 6 50MM CLASS 6	
12.260.	<b>STANDPIPE</b> 15MM X 300MM 15MM X 400MM 15MM X 500MM 15MM X 600MM 15MM X 750MM 15MM X 1000MM 15MM X 1200MM 15MM X 1500MM	





SIGNATURE		NAME (PRINT)	
CAPACITY		DATE	
NAME OF FIRM			

<p>12.261.</p>	<p><b>SPRINKLERS:</b> 4" slim spray head w/ 12' adjustable arc nozzle Saturn III pop-up gear driven sprinkler head (Orbit 5300 series or similar approved) FEATURES AND BENEFITS</p> <ul style="list-style-type: none"> <li>○ Ideal for medium area coverage</li> <li>○ Spray adjusts from a 15-25 ft. Radius in a part- or full-circle pattern</li> <li>○ Gear drive rotor sprinkler with a quiet and smooth rotating spray</li> <li>○ 4 in. Pop-up height</li> <li>○ Removable filter reduces clogging</li> </ul>	
<p>12.262.</p>	<p><b>SPRINKLERS: VOYAGER II PROFESSIONAL POP-UP GEAR DRIVEN SPRINKLER HEAD OR SIMILAR APPROVED</b> FEATURES AND BENEFITS</p> <ul style="list-style-type: none"> <li>○ Ideal for medium to large lawn areas</li> <li>○ Longest spray distance in class - up to 50 feet</li> <li>○ Bonus nozzles included for true matched precipitation</li> <li>○ 3 gallon per minute nozzle pre-installed</li> <li>○ Adjustment key included for easy 40-360 degree setup</li> <li>○ Spray adjusts from a 25 ft. To a 52 ft. Radius in a part or full circle</li> <li>○ 3/4 in. Female threaded</li> <li>○ 4 in. Pop-up height</li> <li>○ Filter reduces clogging</li> </ul>	
<p>12.263.</p>	<p>SPRINKLERS: Rotor pop-up sprinklers (rainbird falcon 6504 rotor or compatible)</p>	
<p>12.264.</p>	<p>SPRINKLERS: Hunter pgg ultra rotor sprinkler heads (or compatible)</p>	
<p>12.265.</p>	<p><b>SPRINKLERS:</b> 1/2 IN. OR 3/4 IN. Satellite II Pop-Up Impact Sprinkler (ORBIT OR SIMILAR APPROVED)</p> <ul style="list-style-type: none"> <li>a. Area coverage up to 80 ft. Diameter in a partial to full circle.</li> <li>b. Replaces most impact and gear sprinklers.</li> <li>c. Flow-through design allows superior performance for systems with dirty water.</li> <li>d. 2 1/2 in. Pop-up height.</li> <li>e. Heavy-duty, uv resistant canister with reinforced ribbed design.</li> <li>F. 1/2 in. Threaded side inlet and 1/2 in. Or 3/4 in. Bottom inlet.</li> </ul>	

SIGNATURE		NAME (PRINT)	
CAPACITY		DATE	
NAME OF FIRM			

12.266.	Sprinklers: SIME pop-up sports gun (PSG)	
12.267.	Nozzle micro rainjet head black rotator 360d micro head complete with spreader and nozzle.	
12.268.	Stake assembly – complete (assembled with: 450mm stake, 600mm tube, barbed adaptor, jet)	<p>Clip Head</p> 
12.269.	Barbed (DISC): 4mm x 4mm	
12.270.	Threaded/barbed: 4mm X 2BA	
12.271.	Nozzle pro 15A spray nozzles	
12.272.	Valve solenoid Orbit Jar Top Automatic inline jar-top valve without flow control. Both ends 1" BSP- threaded	
12.273.	Valve solenoid coil only orbit or compatible	
12.274.	Transformer interchangeable with most brands of 24V timers	
12.275.	Valve box: 250mm round no lock blue / green	

SIGNATURE		NAME (PRINT)	
CAPACITY		DATE	
NAME OF FIRM			

12.276.	Valve box rectangular – economy 460mm x 330mm rectangular valve box with lid	
12.277.	Valve box rectangular irrigation - 380mm x 240mm rectangular valve box with lid	
12.278.	<p>1.1.1. CONTROLLERS: IRRITROL JUNIOR DC (OR COMPATIBLE)</p> <p>1.1.2. KEY FEATURES</p> <p>a) <b>BATTERY-OPERATED</b> provides automatic irrigation in areas with our A.C. power</p> <p>b) <b>WATERPROOF (IP68)</b> to survive the occasional flooded valve box..</p> <p>c) <b>VALVE MOUNT OR WALL MOUNT OPTION</b> mount right on the d.c. solenoid or wall mount up to 900' away</p> <p>d) <b>1- AND 4-STATION MODELS</b> FOR temporary power to one valve or permanent power to a system without A.C.</p> <p>e) <b>COMPATIBLE WITH WIRED RAIN SENSOR™</b> saves water by preventing irrigation during a downpour</p> <p>f) <b>USE IRRITROL DCL, DC LATCHING SOLENOID</b></p>	
12.279.	<p>CONTROLLER ORBIT INDOOR (or compatible)</p> <ul style="list-style-type: none"> <li>• 4 station</li> <li>• 6 station</li> </ul>	

SIGNATURE		NAME (PRINT)	
CAPACITY		DATE	
NAME OF FIRM			



**18. PRICING SCHEDULE**

- NOTE:**
1. Only firm prices will be accepted. Non-firm prices will not be considered.
  2. All delivery costs **MUST** be included in the bid price, for delivery at the prescribed destination.
  3. Document **MUST** be completed in non-erasable black ink.
  4. **NO** correction fluid/tape may be used.
    - a. In the event of a mistake having been made, it shall be crossed out in ink and be accompanied by an initial at each and every alteration.
  5. The Bidder **MUST** indicate whether he/she/the entity is a registered VAT Vendor or not.
    - a. In the case of the Bidder not being a registered VAT Vendor, both columns (amount/rate excluding AND including VAT) must reflect the same amount.

	INDICATE WITH AN 'X'							
	YES		NO					
<b>Are you/is the firm a registered VAT Vendor</b>								
<b>If "YES", please provide VAT number</b>								

I / We \_\_\_\_\_  
 (full name of Bidder) the undersigned in my capacity as \_\_\_\_\_  
 of the firm \_\_\_\_\_

hereby offer to Overstrand Municipality to render the services as described, in accordance with the specification and conditions of contract to the entire satisfaction of the Overstrand Municipality and subject to the conditions of tender, for the amounts indicated hereunder:

**PRICING SCHEDULE:**

P.T.O.

SIGNATURE		NAME (PRINT)	
CAPACITY		DATE	
NAME OF FIRM			



	OM Stock code	Product	Est. Qty.	Does your offer comply with the specifications?		Lead Time	Unit	Manufacturer	Kleinmond Price Per Unit (Incl. VAT)	Hermanus Price Per Unit (Incl. VAT)	Gansbaai Price Per Unit (Incl. VAT)	Indicate Escalation type: ROE (R) Industry (I) CPIX (C)
				Yes	No							
1.	<b>SECTION 1: PIPES AND FITTINGS FOR WATER MAINS</b>											
1.1.	<b>UPVC Pipe Class 6 Socketed Per 6 Meter Length</b>											
1.1.1.	20P001	63mm	75				Length					
1.1.2.	20P002	75mm	5				Length					
1.1.3.	20P003	90mm	15				Length					
1.1.4.	20P004	110mm	35				Length					
1.1.5.	20P005	160mm	15				Length					
1.2.	<b>uPVC Pipe Class 9 Socketed Per 6 Meter Length</b>											
1.2.1.	Non Stock	63mm	1				Length					
1.2.2.	Non Stock	75mm	1				Length					
1.2.3.	Non Stock	90mm	1				Length					
1.2.4.	Non Stock	110mm	1				Length					
1.2.5.	Non Stock	160mm	1				Length					
1.2.6.	Non Stock	200mm	1				Length					
1.2.7.	Non Stock	250mm	1				Length					
1.2.8.	Non Stock	315mm	1				Length					
1.3.	<b>uPVC Pipe Class 12 Socketed / 6 Meter Length</b>											
1.3.1.	11P201	63mm	95				Length					
1.3.2.	11P202	75mm	30				Length					
1.3.3.	11P204	90mm	35				Length					
1.3.4.	11P205	110mm	90				Length					
1.3.5.	11P206	160mm	15				Length					
1.3.6.	Non Stock	200mm	1				Length					
1.3.7.	11P207	250mm	2				Length					
1.3.8.	11P208	315mm	2				Length					

SIGNATURE	NAME (PRINT)	DATE
CAPACITY	NAME OF FIRM	



	OM Stock code	Product	Est. Qty.	Does your offer comply with the specifications?		Lead Time	Unit	Manufacturer	Kleinmond Price Per Unit (Incl. VAT)	Hermanus Price Per Unit (Incl. VAT)	Gansbaai Price Per Unit (Incl. VAT)	Indicate Escalation type: ROE (R) Industry (I) CPIX (C)
				Yes	No							
1.4.	<b>UPVC Pipe Class 12: Bell Mounted Pipe / 4 Meter Length</b>											
1.4.1.	11P100	63mm	25				Length					
1.4.2.	11P101	75mm	40				Length					
1.4.3.	Non Stock	90mm	2				Length					
1.4.4.	11P102	110mm	35				Length					
1.4.5.	11P103	125mm	5				Length					
1.4.6.	11P104	160mm	30				Length					
1.4.7.	11P105	200mm	11				Length					
1.4.8.	11P005	250mm	1				Length					
1.4.9.	Non Stock	315mm	1				Length					
1.5.	<b>uPVC Bends 11.25° Class 6 Solvent Weld</b>											
1.5.1.	20B001	63mm	10				Each					
1.5.2.	Non Stock	75mm	1				Each					
1.5.3.	Non Stock	90mm	1				Each					
1.5.4.	Non Stock	110mm	1				Each					
1.5.5.	Non Stock	160mm	1				Each					
1.6.	<b>uPVC Bends 22.5° Class 6 Solvent Weld</b>											
1.6.1.	20B002	63mm	55				Each					
1.6.2.	20B005	75mm	5				Each					
1.6.3.	20B008	90mm	5				Each					
1.6.4.	20B011	110mm	15				Each					
1.6.5.	Non Stock	160mm	2				Each					
1.7.	<b>uPVC Bends 45° Class 6 Solvent Weld</b>											
1.7.1.	20B003	63mm	65				Each					
1.7.2.	20B006	75mm	5				Each					

SIGNATURE		NAME (PRINT)		DATE	
CAPACITY		NAME OF FIRM			



	OM Stock code	Product	Est. Qty.	Does your offer comply with the specifications?		Lead Time	Unit	Manufacturer	Kleinmond Price Per Unit (Incl. VAT)	Hermanus Price Per Unit (Incl. VAT)	Gansbaai Price Per Unit (Incl. VAT)	Indicate Escalation type: ROE (R) Industry (I) CPIX (C)
				Yes	No							
1.7.3.	20B009	90mm	5				Each					
1.7.4.	20B012	110mm	25				Each					
1.7.5.	Non Stock	160mm	5				Each					
1.8.	<b>uPVC Bends 90° Class 6 Solvent Weld</b>											
1.8.1.	20B004	63mm	85				Each					
1.8.2.	20B007	75mm	2				Each					
1.8.3.	20B010	90mm	2				Each					
1.8.4.	20B014	110mm	2				Each					
1.8.5.	Non Stock	160mm	2				Each					
1.9.	<b>uPVC Bends 11.25° Class 12 Socketed</b>											
1.9.1.	Non Stock	63mm	2				Each					
1.9.2.	Non Stock	75mm	2				Each					
1.9.3.	Non Stock	90mm	2				Each					
1.9.4.	Non Stock	110mm	2				Each					
1.9.5.	Non Stock	160mm	2				Each					
1.10.	<b>uPVC Bends 22.5° Class 12 Socketed</b>											
1.10.1.	Non Stock	63mm	2				Each					
1.10.2.	Non Stock	75mm	2				Each					
1.10.3.	Non Stock	90mm	2				Each					
1.10.4.	Non Stock	110mm	2				Each					
1.10.5.	Non Stock	160mm	2				Each					
1.11.	<b>uPVC Bends 45° Class 12 Socketed</b>											
1.11.1.	Non Stock	63mm	2				Each					
1.11.2.	Non Stock	75mm	2				Each					
1.11.3.	Non Stock	90mm	2				Each					

SIGNATURE	NAME (PRINT)	DATE
CAPACITY	NAME OF FIRM	



	OM Stock code	Product	Est. Qty.	Does your offer comply with the specifications?		Lead Time	Unit	Manufacturer	Kleinmond Price Per Unit (Incl. VAT)	Hermanus Price Per Unit (Incl. VAT)	Gansbaai Price Per Unit (Incl. VAT)	Indicate Escalation type: ROE (R) Industry (I) CPIX (C)
				Yes	No							
1.11.4.	Non Stock	110mm	2				Each					
1.11.5.	11B100	160mm	6				Each					
1.12.	<b>uPVC Bends 90° Class 12 Socketed</b>											
1.12.1.	Non Stock	63mm	2				Each					
1.12.2.	Non Stock	75mm	2				Each					
1.12.3.	Non Stock	90mm	2				Each					
1.12.4.	Non Stock	110mm	2				Each					
1.12.5.	Non Stock	160mm	2				Each					
1.13.	<b>End Caps – uPVC Class 6 Solvent Weld</b>											
1.13.1.	20S100	63mm	90				Each					
1.13.2.	20S101	75mm	5				Each					
1.13.3.	20S102	90mm	5				Each					
1.13.4.	20S103	110mm	20				Each					
1.13.5.	20S104	160mm	5				Each					
1.14.	<b>Reducers – PVC Class 6</b>											
1.14.1.	20R001	75mm to 63mm	2				Each					
1.14.2.	20R002	90mm to 63mm	2				Each					
1.14.3.	20R003	90mm to 75mm	2				Each					
1.14.4.	20R004	110mm to 63mm	2				Each					
1.14.5.	20R005	110mm to 75mm	2				Each					
1.14.6.	20R006	110mm to 90mm	2				Each					
1.15.	<b>Reducers – PVC Class 12</b>											
1.15.1.	Non Stock	75mm to 63mm	2				Each					
1.15.2.	Non Stock	90mm to 63mm	2				Each					
1.15.3.	Non Stock	110mm to 63mm	2				Each					

SIGNATURE		NAME (PRINT)		DATE	
CAPACITY		NAME OF FIRM			



	OM Stock code	Product	Est. Qty.	Does your offer comply with the specifications?		Lead Time	Unit	Manufacturer	Kleinmond Price Per Unit (Incl. VAT)	Hermanus Price Per Unit (Incl. VAT)	Gansbaai Price Per Unit (Incl. VAT)	Indicate Escalation type: ROE (R) Industry (I) CPIX (C)
				Yes	No							
1.15.4.	Non Stock	90mm to 75mm	2				Each					
1.15.5.	Non Stock	110mm to 75mm	2				Each					
1.15.6.	Non Stock	110mm to 90mm	2				Each					
1.16.	<b>PVC Repair Couplings Class 12</b>											
1.16.1.	11R305	63mm	5				Each					
1.16.2.	11R301	75mm	12				Each					
1.16.3.	11R302	90mm	5				Each					
1.16.4.	11R303	110mm	6				Each					
1.16.5.	11R304	160mm	6				Each					
1.16.6.	11R305	200mm	1				Each					
1.16.7.	11R306	315mm	1				Each					
1.17.	<b>PVC Sockets Class 6 Solvent Weld</b>											
1.17.1.	20S001	63mm	60				Each					
1.17.2.	20S002	75mm	2				Each					
1.17.3.	20S003	90mm	5				Each					
1.17.4.	20S004	110mm	25				Each					
1.17.5.	Non Stock	160mm	1				Each					
1.18.	<b>PVC to AC Adaptors Class 12</b>											
1.18.1.	11A002	63 mm PVC to 50 mm AC	50				Each					
1.18.2.	11A003	75 mm PVC to 75 mm AC	50				Each					
1.18.3.	11A005	90 mm PVC to 100 mm AC	10				Each					
1.18.4.	11A006	110 mm PVC to 100 mm AC	70				Each					
1.18.5.	Non Stock	110 mm PVC to 125 mm AC	1				Each					
1.18.6.	11A007	160 mm PVC to 150 mm AC	30				Each					
1.18.7.	11A008	200 mm PVC to 200 mm AC	5				Each					

SIGNATURE		NAME (PRINT)		DATE	
CAPACITY		NAME OF FIRM			



	OM Stock code	Product	Est. Qty.	Does your offer comply with the specifications?		Lead Time	Unit	Manufacturer	Kleinmond Price Per Unit (Incl. VAT)	Hermanus Price Per Unit (Incl. VAT)	Gansbaai Price Per Unit (Incl. VAT)	Indicate Escalation type: ROE (R) Industry (I) CPIX (C)
				Yes	No							
1.18.8.	11A009	200 mm PVC to 225 mm AC	1				Each					
1.18.9.	11A010	250 mm PVC to 250 mm AC	2				Each					
1.18.10.	11A100	315 mm PVC to 345 mm AC	2				Each					
1.19.	<b>Y-Junctions Class 6</b>											
1.19.1.	20Y001	63mm x 63mm	40				Each					
1.19.2.	20Y003	75mm x 75mm	3				Each					
1.19.3.	20Y006	90mm x 90mm	3				Each					
1.19.4.	20Y007	110mm x 110mm	12				Each					
1.19.5.	20Y002	75mm x 63mm	3				Each					
1.19.6.	20Y004	90mm x 63mm	20				Each					
1.19.7.	20Y008	110mm x 63mm	15				Each					
1.19.8.	20Y005	90mm x 75mm	10				Each					
1.19.9.	Non Stock	110mm x 75mm	1				Each					
1.19.10.	20Y009	110mm x 90mm	5				Each					
1.20.	<b>Y-Junctions Class 12</b>											
1.20.1.	Non Stock	63mm x 63mm	2				Each					
1.20.2.	Non Stock	75mm x 75mm	2				Each					
1.20.3.	Non Stock	90mm x 90mm	2				Each					
1.20.4.	Non Stock	110mm x 110mm	2				Each					
1.20.5.	Non Stock	75mm x 63mm	2				Each					
1.20.6.	Non Stock	90mm x 63mm	2				Each					
1.20.7.	Non Stock	110mm x 63mm	2				Each					
1.20.8.	Non Stock	90mm x 75mm	2				Each					
1.20.9.	Non Stock	110mm x 75mm	2				Each					
1.20.10.	Non Stock	110mm x 90mm	2				Each					

SIGNATURE	NAME (PRINT)	DATE
CAPACITY	NAME OF FIRM	



	OM Stock code	Product	Est. Qty.	Does your offer comply with the specifications?		Lead Time	Unit	Manufacturer	Kleinmond Price Per Unit (Incl. VAT)	Hermanus Price Per Unit (Incl. VAT)	Gansbaai Price Per Unit (Incl. VAT)	Indicate Escalation type: ROE (R) Industry (I) CPIX (C)
				Yes	No							
1.21.	<b>20F002</b>	<b>PVC Sewer Filters</b>	<b>100</b>				Each					
1.22.	<b>Cast Iron Short Collar Couplings</b>											
1.22.1.	11C100	50mm	<b>60</b>				Each					
1.22.2.	11C101	75mm	<b>50</b>				Each					
1.22.3.	11C102	100mm	<b>50</b>				Each					
1.22.4.	11C103	125mm	<b>10</b>				Each					
1.22.5.	11C104	150mm	<b>25</b>				Each					
1.22.6.	11C105	200mm	<b>12</b>				Each					
1.22.7.	11C106	225mm	<b>1</b>				Each					
1.22.8.	11C107	250mm	<b>1</b>				Each					
1.22.9.	11C108	300mm	<b>2</b>				Each					
1.23.	<b>Universal / Ranger Couplings</b>											
1.23.1.	11C301	59mm – 73mm to suit 63mm PVC Pipe	<b>10</b>				Each					
1.23.2.	11C302	72mm – 85mm to suit 75mm PVC Pipe	<b>2</b>				Each					
1.23.3.	11C304	88mm – 103mm to suit 90mm PVC Pipe	<b>20</b>				Each					
1.23.4.	11C305	108mm – 128mm to suit 110mm PVC Pipe	<b>10</b>				Each					
1.23.5.	11C306	159mm – 182mm to suit 160mm PVC Pipe	<b>10</b>				Each					
1.23.6.	11C307	192mm – 209mm to suit 200mm PVC Pipe	<b>1</b>				Each					
1.23.7.	11C308	250mm – 267mm to suit 250mm PVC Pipe	<b>1</b>				Each					
1.23.8.	11C309	315mm – 332mm to suit 315mm PVC Pipe	<b>1</b>				Each					
1.24.	<b>Cast Iron Saddles</b>											
1.24.1.	<b>22mm Drill to Suit AC Pipe</b>											
1.24.1.1.	11S001	50mm	<b>60</b>				Each					
1.24.1.2.	11S002	75mm	<b>65</b>				Each					
1.24.1.3.	11S005	100mm	<b>50</b>				Each					

SIGNATURE	NAME (PRINT)	DATE
CAPACITY	NAME OF FIRM	



	OM Stock code	Product	Est. Qty.	Does your offer comply with the specifications?		Lead Time	Unit	Manufacturer	Kleinmond Price Per Unit (Incl. VAT)	Hermanus Price Per Unit (Incl. VAT)	Gansbaai Price Per Unit (Incl. VAT)	Indicate Escalation type: ROE (R) Industry (I) CPIX (C)
				Yes	No							
1.24.1.4.	Non Stock	125mm	1				Each					
1.24.1.5.	11S009	150mm	20				Each					
1.24.1.6.	11S012	200mm	10				Each					
1.24.1.7.	11S013	225mm	3				Each					
1.24.1.8.	Non Stock	250mm	3				Each					
1.24.1.9.	11S015	300mm	2				Each					
<b>1.24.2.</b>	<b>40mm Drill to Suit AC Pipe</b>											
1.24.2.1.	Non Stock	75mm	1				Each					
1.24.2.2.	11S007	100mm	2				Each					
1.24.2.3.	Non Stock	125mm	1				Each					
1.24.2.4.	11S011	150mm	2				Each					
1.24.2.5.	Non Stock	200mm	1				Each					
1.24.2.6.	Non Stock	225mm	1				Each					
1.24.2.7.	Non Stock	250mm	1				Each					
1.24.2.8.	Non Stock	300mm	1				Each					
<b>1.24.3.</b>	<b>AC / PVC; 22mm Drill</b>											
1.24.3.1.	Non Stock	63mm	1				Each					
1.24.3.2.	11S100	75mm	10				Each					
1.24.3.3.	Non Stock	90mm	1				Each					
1.24.3.4.	11S101	110mm	20				Each					
1.24.3.5.	Non Stock	160mm	1				Each					
<b>1.24.4.</b>	<b>AC / PVC; 42mm Drill</b>											
1.24.4.1.	Non Stock	63mm	1				Each					
1.24.4.2.	Non Stock	75mm	1				Each					
1.24.4.3.	Non Stock	90mm	1				Each					

SIGNATURE	NAME (PRINT)	DATE
CAPACITY	NAME OF FIRM	



	OM Stock code	Product	Est. Qty.	Does your offer comply with the specifications?		Lead Time	Unit	Manufacturer	Kleinmond Price Per Unit (Incl. VAT)	Hermanus Price Per Unit (Incl. VAT)	Gansbaai Price Per Unit (Incl. VAT)	Indicate Escalation type: ROE (R) Industry (I) CPIX (C)
				Yes	No							
1.24.4.4.	Non Stock	110mm	1				Each					
1.24.4.5.	11S102	160mm	5				Each					
<b>1.24.5.</b>	<b>Stainless Steel Repair Clamps</b>											
1.24.5.1.	11R200	69mm – 76mm to suit 50mm AC Pipe	85				Each					
1.24.5.2.	11R201	95mm – 104mm to suit 75mm AC Pipe	75				Each					
1.24.5.3.	11R202	120mm – 130mm to suit 100mm AC Pipe	65				Each					
1.24.5.4.	11R203	145mm – 155mm to suit 125mm AC Pipe	6				Each					
1.24.5.5.	11R204	173mm – 183mm to suit 150mm AC Pipe	30				Each					
1.24.5.6.	11R205	229mm – 238mm to suit 200mm AC Pipe	20				Each					
1.24.5.7.	11R206	254mm – 264mm to suit 225mm AC Pipe	2				Each					
1.24.5.8.	11R207	281mm – 290mm to suit 250mm AC Pipe	2				Each					
1.24.5.9.	11R208	342mm – 356mm to suit 300mm AC Pipe	2				Each					
<b>1.24.6.</b>	<b>Flange Adaptors</b>											
1.24.6.1.	11F001	50mm AC to 63mm PVC (59-73mm)	6				Each					
1.24.6.2.	11F002	75 mm AC to 75 mm PVC (72-85mm)	2				Each					
1.24.6.3.	11F003	100 mm AC to 110 mm PVC (108-128mm)	10				Each					
1.24.6.4.	11F004	150 mm AC to 160 mm PVC (159-182mm)	1				Each					
1.24.6.5.	11F005	225 mm AC to 250 mm PVC (250-267mm)	1				Each					
<b>1.25.</b>	<b>Bends</b>											
<b>1.25.1.</b>	<b>11.25° Ductile Iron Socketed</b>											
1.25.1.1.	Non Stock	63mm	1				Each					
1.25.1.2.	Non Stock	75mm	1				Each					
1.25.1.3.	Non Stock	90mm	1				Each					
1.25.1.4.	Non Stock	110mm	1				Each					
1.25.1.5.	Non Stock	160mm	1				Each					

SIGNATURE	NAME (PRINT)	DATE
CAPACITY	NAME OF FIRM	



	OM Stock code	Product	Est. Qty.	Does your offer comply with the specifications?		Lead Time	Unit	Manufacturer	Kleinmond Price Per Unit (Incl. VAT)	Hermanus Price Per Unit (Incl. VAT)	Gansbaai Price Per Unit (Incl. VAT)	Indicate Escalation type: ROE (R) Industry (I) CPIX (C)
				Yes	No							
<b>1.25.2.</b>	<b>22.5° Ductile Iron Socketed</b>											
1.25.2.1.	Non Stock	63mm	1				Each					
1.25.2.2.	Non Stock	75mm	1				Each					
1.25.2.3.	Non Stock	90mm	1				Each					
1.25.2.4.	Non Stock	110mm	1				Each					
1.25.2.5.	Non Stock	160mm	1				Each					
<b>1.25.3.</b>	<b>45° Ductile Iron Socketed</b>											
1.25.3.1.	Non Stock	63mm	1				Each					
1.25.3.2.	Non Stock	75mm	1				Each					
1.25.3.3.	Non Stock	90mm	1				Each					
1.25.3.4.	Non Stock	110mm	1				Each					
1.25.3.5.	Non Stock	160mm	1				Each					
<b>1.25.4.</b>	<b>90° Ductile Iron Socketed</b>											
1.25.4.1.	Non Stock	63mm	1				Each					
1.25.4.2.	Non Stock	75mm	1				Each					
1.25.4.3.	Non Stock	90mm	1				Each					
1.25.4.4.	Non Stock	110mm	1				Each					
1.25.4.5.	Non Stock	160mm	1				Each					
1.26.	<b>End Caps</b>											
<b>1.26.1.</b>	<b>Ductile Iron Socketed</b>											
1.26.1.1.	Non Stock	63mm	1				Each					
1.26.1.2.	Non Stock	75mm	1				Each					
1.26.1.3.	Non Stock	90mm	1				Each					
1.26.1.4.	Non Stock	110mm	1				Each					

SIGNATURE	NAME (PRINT)	DATE
CAPACITY	NAME OF FIRM	



	OM Stock code	Product	Est. Qty.	Does your offer comply with the specifications?		Lead Time	Unit	Manufacturer	Kleinmond Price Per Unit (Incl. VAT)	Hermanus Price Per Unit (Incl. VAT)	Gansbaai Price Per Unit (Incl. VAT)	Indicate Escalation type: ROE (R) Industry (I) CPIX (C)
				Yes	No							
1.26.1.5.	Non Stock	160mm	1				Each					
1.26.1.6.	Non Stock	200mm	1				Each					
<b>1.26.2.</b>	<b>Cast Iron To Suit AC Pipe</b>											
1.26.2.1.	11S400	50mm	1				Each					
1.26.2.2.	11S401	75mm	1				Each					
1.26.2.3.	11S402	100mm	1				Each					
1.26.2.4.	11S404	150mm	2				Each					
1.26.2.5.	11S405	225mm	1				Each					
<b>1.26.3.</b>	<b>Reducers – Ductile Iron Socketed</b>											
1.26.3.1.	Non Stock	75mm to 63mm	1				Each					
1.26.3.2.	Non Stock	90mm to 63mm	1				Each					
1.26.3.3.	Non Stock	110mm to 63mm	1				Each					
1.26.3.4.	Non Stock	90mm to 75mm	1				Each					
1.26.3.5.	Non Stock	110mm to 75mm	1				Each					
1.26.3.6.	Non Stock	110mm to 90mm	1				Each					
1.26.3.7.	Non Stock	160mm to 110mm	1				Each					
<b>1.27.</b>	<b>Tees</b>											
<b>1.27.1.</b>	<b>Cast Iron to Suit AC Pipe</b>											
1.27.1.1.	Non Stock	50mm Equal Tee	1				Each					
1.27.1.2.	Non Stock	75mm x 50mm	1				Each					
1.27.1.3.	11T202	75mm Equal Tee	1				Each					
1.27.1.4.	11T203	100mm Equal Tee	1				Each					
1.27.1.5.	11T206	150mm x 100mm	1				Each					

SIGNATURE		NAME (PRINT)		DATE	
CAPACITY			NAME OF FIRM		



	OM Stock code	Product	Est. Qty.	Does your offer comply with the specifications?		Lead Time	Unit	Manufacturer	Kleinmond Price Per Unit (Incl. VAT)	Hermanus Price Per Unit (Incl. VAT)	Gansbaai Price Per Unit (Incl. VAT)	Indicate Escalation type: ROE (R) Industry (I) CPIX (C)
				Yes	No							
1.27.1.6.	11T207	150mm Equal Tee	1				Each					
1.27.1.7.	11T209	225mm equal Tee	1				Each					
<b>1.27.2.</b>	<b>Ductile Iron to Suit PVC Pipe</b>											
1.27.2.1.	Non Stock	63mm Equal Tee	1				Each					
1.27.2.2.	Non Stock	75mm x 63mm	1				Each					
1.27.2.3.	Non Stock	75mm Equal Tee	1				Each					
1.27.2.4.	Non Stock	110mm equal Tee	1				Each					
1.27.2.5.	Non Stock	160mm x 110mm	1				Each					
1.27.2.6.	Non Stock	160mm Equal Tee	1				Each					
1.27.2.7.	Non Stock	200mm Equal Tee	1				Each					
<b>1.27.3.</b>	<b>Hydrant Tees To Suit PVC Pipe</b>											
1.27.3.1.	Non Stock	63mm	1				Each					
1.27.3.2.	Non Stock	75mm	1				Each					
1.27.3.3.	Non Stock	90mm	1				Each					
1.27.3.4.	Non Stock	110mm	1				Each					
1.27.3.5.	Non Stock	160mm	1				Each					
1.27.3.6.	Non Stock	200mm	1				Each					
1.27.3.7.	Non Stock	250mm	1				Each					
1.27.3.8.	Non Stock	315mm	1				Each					
<b>1.27.4.</b>	<b>Hydrant Tees to Suit AC Pipe</b>											
1.27.4.1.	11H001	75mm	2				Each					
1.27.4.2.	11H002	100mm	1				Each					
1.27.4.3.	11H003	150mm	1				Each					
1.27.4.4.	11H004	225mm	1				Each					

SIGNATURE		NAME (PRINT)		DATE	
CAPACITY			NAME OF FIRM		



	OM Stock code	Product	Est. Qty.	Does your offer comply with the specifications?		Lead Time	Unit	Manufacturer	Kleinmond Price Per Unit (Incl. VAT)	Hermanus Price Per Unit (Incl. VAT)	Gansbaai Price Per Unit (Incl. VAT)	Indicate Escalation type: ROE (R) Industry (I) CPIX (C)
				Yes	No							
<b>1.27.5.</b>	<b>Flanged</b>											
1.27.5.1.	Non Stock	75mm	1				Each					
1.27.5.2.	Non Stock	100mm	1				Each					
1.27.5.3.	Non Stock	150mm	1				Each					
1.27.5.4.	Non Stock	225mm	1				Each					
<b>1.28.</b>	<b>Hydrant Valves</b>											
1.28.1.	11H300	Fire Hydrant Cap top valve multi drilled	20				Each					
<b>1.29.</b>	<b>Gate Valves:</b>											
<b>1.29.1.</b>	<b>Flanged, Hand wheel Operated (Drilled Table D, BS 10)</b>											
1.29.1.1.	11V205	150mm	6				Each					
<b>1.29.2.</b>	<b>Cap Top – Socketed To Suit PVC Pipe</b>											
1.29.2.1.	11V101	63mm	1				Each					
1.29.2.2.	11V102	75mm	4				Each					
1.29.2.3.	Non Stock	90mm	1				Each					
1.29.2.4.	11V104	110mm	5				Each					
1.29.2.5.	11V106	160mm	1				Each					
1.29.2.6.	11V107	200mm	1				Each					
1.29.2.7.	Non Stock	250mm	1				Each					
1.29.2.8.	Non Stock	315mm	1				Each					
<b>1.29.3.</b>	<b>Cap Top - Plain Ended</b>											
1.29.3.1.	11V001	50mm	16				Each					
1.29.3.2.	11V002	75mm	10				Each					
1.29.3.3.	11V003	100mm	6				Each					
1.29.3.4.	11V007	150mm	3				Each					
1.29.3.5.	11V008	200mm	1				Each					

SIGNATURE	NAME (PRINT)	DATE
CAPACITY	NAME OF FIRM	



	OM Stock code	Product	Est. Qty.	Does your offer comply with the specifications?		Lead Time	Unit	Manufacturer	Kleinmond Price Per Unit (Incl. VAT)	Hermanus Price Per Unit (Incl. VAT)	Gansbaai Price Per Unit (Incl. VAT)	Indicate Escalation type: ROE (R) Industry (I) CPIX (C)
				Yes	No							
<b>1.29.4.</b>	<b>Gate Valves C X C Brass</b>											
1.29.4.1.	Non Stock	15mm	1				Each					
1.29.4.2.	Non Stock	20mm	1				Each					
1.29.4.3.	Non Stock	25mm	1				Each					
1.29.4.4.	10G003	40mm	10				Each					
1.29.4.5.	Non Stock	50mm	1				Each					
<b>1.29.5.</b>	<b>Gate Valves F X F Brass</b>											
1.29.5.1.	Non Stock	15mm	1				Each					
1.29.5.2.	10G001	20mm	120				Each					
1.29.5.3.	10G002	25mm	10				Each					
1.29.5.4.	10G004	40mm	12				Each					
1.29.5.5.	10G005	50mm	5				Each					
<b>1.30.</b>	<b>Non-Return Valves</b>											
1.30.1.	Non Stock	63mm	1				Each					
1.30.2.	Non Stock	75mm	1				Each					
1.30.3.	Non Stock	90mm	1				Each					
1.30.4.	Non Stock	110mm	1				Each					
1.30.5.	Non Stock	160mm	1				Each					
1.30.6.	Non Stock	200mm	1				Each					
1.30.7.	Non Stock	250mm	1				Each					
1.30.8.	Non Stock	315mm	1				Each					
<b>1.31.</b>	<b>Ventomat (or Similar) Rbx Air Release Valves and Vacuum Break Valves (Stainless Steel)</b>											
1.31.1.	Non Stock	28mm	1				Each					
1.31.2.	Non Stock	50mm	1				Each					

SIGNATURE		NAME (PRINT)		DATE	
CAPACITY			NAME OF FIRM		



	OM Stock code	Product	Est. Qty.	Does your offer comply with the specifications?		Lead Time	Unit	Manufacturer	Kleinmond Price Per Unit (Incl. VAT)	Hermanus Price Per Unit (Incl. VAT)	Gansbaai Price Per Unit (Incl. VAT)	Indicate Escalation type: ROE (R) Industry (I) CPIX (C)
				Yes	No							
1.32.	<b>MUNICIPAL BALL COCKS</b>											
1.32.1.	Non Stock	15mm	1				Each					
1.32.2.	10B001	22mm	400				Each					
1.32.3.	Non Stock	28mm	1				Each					
1.33.	<b>Ball Valves</b>											
1.33.1.	<b>Ball Valves MXF Chrome Plated</b>											
1.33.1.1.	Non Stock	20mm	1				Each					
1.33.1.2.	10B102	25mm	13				Each					
1.33.1.3.	10B103	32mm	1				Each					
1.33.1.4.	10B105	40mm	10				Each					
1.33.1.5.	10B107	50mm	1				Each					
1.33.1.6.	Non Stock	80mm	1				Each					
1.33.2.	<b>Ball Valves FXF Chrome Plated</b>											
1.33.2.1.	10B101	20mm	90				Each					
1.33.2.2.	Non Stock	25mm	1				Each					
1.33.2.3.	Non Stock	32mm	1				Each					
1.33.2.4.	10B104	40mm	10				Each					
1.33.2.5.	Non Stock	50mm	1				Each					
1.33.2.6.	10B106	80mm	15				Each					
1.34.	<b>DZR Brass Compression Fittings (J.A.S.W.I.C Accepted)</b>											
1.34.1.	<b>Running Nipple Brass</b>											
1.34.1.1.	10B200	20mm	25				Each					
1.34.2.	<b>Couplers C X C Brass</b>											
1.34.2.1.	10C001	15mm	420				Each					
1.34.2.2.	10C004	22mm	780				Each					

SIGNATURE		NAME (PRINT)		DATE	
CAPACITY		NAME OF FIRM			



	OM Stock code	Product	Est. Qty.	Does your offer comply with the specifications?		Lead Time	Unit	Manufacturer	Kleinmond Price Per Unit (Incl. VAT)	Hermanus Price Per Unit (Incl. VAT)	Gansbaai Price Per Unit (Incl. VAT)	Indicate Escalation type: ROE (R) Industry (I) CPIX (C)
				Yes	No							
1.34.2.3.	10C007	28mm	40				Each					
1.34.2.4.	10C010	32mm	10				Each					
1.34.2.5.	10C012	42mm	45				Each					
<b>1.34.3.</b>	<b>Couplers Female X Copper Brass</b>											
1.34.3.1.	10C002	15mm	315				Each					
1.34.3.2.	10C005	22mm	1045				Each					
1.34.3.3.	10C021	28mm	16				Each					
1.34.3.4.	10C011	32mm	5				Each					
1.34.3.5.	10C013	42mm	40				Each					
<b>1.34.4.</b>	<b>Couplers Male X Copper Brass</b>											
1.34.4.1.	10C003	15mm	150				Each					
1.34.4.2.	10C006	22mm	1000				Each					
1.34.4.3.	10C009	28mm	20				Each					
1.34.4.4.	Non Stock	32mm	1				Each					
1.34.4.5.	10C014	42mm	40				Each					
<b>1.34.5.</b>	<b>Reducer Couplers Copper X Copper Brass</b>											
1.34.5.1.	10R001	22mm x 15mm	400				Each					
1.34.5.2.	10R003	28mm x 22mm	80				Each					
<b>1.34.6.</b>	<b>Reducer Couplers Male X Copper Brass</b>											
1.34.6.1.	10R002	22mm x 15mm	30				Each					
1.34.6.2.	Non Stock	28mm x 22mm	1				Each					
<b>1.34.7.</b>	<b>Multi Step Reducer Set Brass</b>											
1.34.7.1.	10R011	42mm x 22mm	10				Each					
1.34.7.2.	10R012	42mm x 28mm	5				Each					

SIGNATURE		NAME (PRINT)		DATE	
CAPACITY			NAME OF FIRM		



	OM Stock code	Product	Est. Qty.	Does your offer comply with the specifications?		Lead Time	Unit	Manufacturer	Kleinmond Price Per Unit (Incl. VAT)	Hermanus Price Per Unit (Incl. VAT)	Gansbaai Price Per Unit (Incl. VAT)	Indicate Escalation type: ROE (R) Industry (I) CPIX (C)
				Yes	No							
<b>1.34.8.</b>	<b>Elbows Copper X Copper Brass</b>											
1.34.8.1.	10E001	15mm	450				Each					
1.34.8.2.	10E005	22mm	700				Each					
1.34.8.3.	10E010	28mm	20				Each					
1.34.8.4.	Non Stock	35mm	1				Each					
1.34.8.5.	10E015	42mm	30				Each					
<b>1.34.9.</b>	<b>Elbows Female X Copper Brass</b>											
1.34.9.1.	10E002	15mm	190				Each					
1.34.9.2.	10E006	22mm	600				Each					
1.34.9.3.	10E011	28mm	20				Each					
1.34.9.4.	10E013	35mm	15				Each					
1.34.9.5.	10E016	42mm	15				Each					
<b>1.34.10.</b>	<b>Elbows Male X Copper Brass</b>											
1.34.10.1.	10E003	15mm	125				Each					
1.34.10.2.	10E007	22mm	760				Each					
1.34.10.3.	10E012	28mm	15				Each					
1.34.10.4.	10E014	35mm	5				Each					
1.34.10.5.	10E017	42mm	30				Each					
<b>1.34.11.</b>	<b>Elbows Wall-Plate Brass</b>											
1.34.11.1.	10E004	15mm	60				Each					
1.34.11.2.	10E008	20mm	25				Each					
<b>1.34.12.</b>	<b>Elbows Reducing C X C Brass</b>											
1.34.12.1.	Non Stock	20mm x 15mm	1				Each					

SIGNATURE		NAME (PRINT)		DATE	
CAPACITY			NAME OF FIRM		



	OM Stock code	Product	Est. Qty.	Does your offer comply with the specifications?		Lead Time	Unit	Manufacturer	Kleinmond Price Per Unit (Incl. VAT)	Hermanus Price Per Unit (Incl. VAT)	Gansbaai Price Per Unit (Incl. VAT)	Indicate Escalation type: ROE (R) Industry (I) CPIX (C)
				Yes	No							
<b>1.34.13.</b>	<b>Tees Brass Equal Brass</b>											
1.34.13.1.	10T300	15mm	240									
1.34.13.2.	10T301	22mm	200									
1.34.13.3.	10T302	28mm	5									
1.34.13.4.	Non Stock	35mm	1									
1.34.13.5.	10T303	42mm	10									
1.34.13.6.	Non Stock	54mm	1									
<b>1.34.14.</b>	<b>Tees Reducing Brass</b>											
1.34.14.1.	10T330	15mm x 15mm 22mm	30									
1.34.14.2.	10T332	22mm x 22mm 28mm	10									
<b>1.34.15.</b>	<b>Tees Reducing Branch Brass</b>											
1.34.15.1.	10T331	22mm x 22mm x 15mm	30									
1.34.15.2.	10T333	28mm x 28mm x 22mm	6									
<b>1.34.16.</b>	<b>Conex Rings</b>											
1.34.16.1.	10R100	15mm	50				Each					
1.34.16.2.	10R101	20mm	60				Each					
<b>1.34.17.</b>	<b>Conex Stop Ends</b>											
1.34.17.1.	10S001	15mm	55				Each					
1.34.17.2.	10S002	20mm	30				Each					
<b>1.35.</b>	<b>Brass Taps</b>											
<b>1.35.1.</b>	<b>Hose Bib-Cocks</b>											
1.35.1.1.	10T200	15mm	80				Each					
1.35.1.2.	10T201	20mm	20				Each					

SIGNATURE		NAME (PRINT)		DATE	
CAPACITY			NAME OF FIRM		



	OM Stock code	Product	Est. Qty.	Does your offer comply with the specifications?		Lead Time	Unit	Manufacturer	Kleinmond Price Per Unit (Incl. VAT)	Hermanus Price Per Unit (Incl. VAT)	Gansbaai Price Per Unit (Incl. VAT)	Indicate Escalation type: ROE (R) Industry (I) CPIX (C)
				Yes	No							
<b>1.35.2.</b>	<b>Stopcocks: C X C</b>											
1.35.2.1.	10T210	15mm	150				Each					
1.35.2.2.	10T212	20mm	450				Each					
1.35.2.3.	10T215	25mm	12				Each					
1.35.2.4.	10T216	38mm	6				Each					
1.35.2.5.	Non Stock	42mm	1				Each					
<b>1.35.3.</b>	<b>Stopcocks: Female</b>											
1.35.3.1.	10T211	15mm	60				Each					
1.35.3.2.	10T213	20mm	2350				Each					
1.35.3.3.	10T214	25mm	5				Each					
1.35.3.4.	Non Stock	38mm	1				Each					
1.35.3.5.	Non Stock	42mm	1				Each					
<b>1.35.4.</b>	<b>Stopcocks: Male</b>											
1.35.4.1.	Non Stock	15mm	1				Each					
1.35.4.2.	Non Stock	20mm	1				Each					
1.35.4.3.	Non Stock	25mm	1				Each					
1.35.4.4.	Non Stock	38mm	1				Each					
1.35.4.5.	Non Stock	42mm	1				Each					
<b>1.35.5.</b>	<b>Stop Cocks: Plastic Male Male</b>											
1.35.5.1.	Non Stock	15mm	1				Each					
1.35.5.2.	Non Stock	20mm	1				Each					
<b>1.35.6.</b>	<b>Taps Pushbutton</b>											
1.35.6.1.	10T230	15mm	1				Each					
1.35.6.2.	10T231	20mm	5				Each					

SIGNATURE		NAME (PRINT)		DATE	
CAPACITY			NAME OF FIRM		



	OM Stock code	Product	Est. Qty.	Does your offer comply with the specifications?		Lead Time	Unit	Manufacturer	Kleinmond Price Per Unit (Incl. VAT)	Hermanus Price Per Unit (Incl. VAT)	Gansbaai Price Per Unit (Incl. VAT)	Indicate Escalation type: ROE (R) Industry (I) CPIX (C)
				Yes	No							
<b>1.35.7.</b>	<b>Loose Key Bib-Cocks : Male</b>											
1.35.7.1.	10T232	20mm	15				Each					
<b>1.35.8.</b>	<b>Loose Key Bib-Cocks : Female Male</b>											
1.35.8.1.	10T233	20mm	1				Each					
<b>1.35.9.</b>	<b>Plastic Hose Bib-Cocks</b>											
1.35.9.1.	10T240	15mm	330				Each					
1.35.9.2.	Non Stock	20mm	1				Each					
<b>1.35.10.</b>	<b>Tap Jumpers</b>											
1.35.10.1.	10T100	15mm	5				Each					
1.35.10.2.	10T101	20mm	5				Each					
<b>1.35.11.</b>	<b>PIPE Copper Tubes Class 2 (5.5 Meter)</b>											
1.35.11.1.	10P001	15mm	30				/ length					
1.35.11.2.	10P002	20mm	40				/ length					
<b>1.35.12.</b>	<b>Y Brass Strainer</b>											
1.35.12.1.	63S002	Y In-Line Strainer Brass Valve	25									
<b>1.35.13.</b>	<b>Tail pieces Brass</b>											
1.35.13.1.		15MM Kent Tailpiece HZ011 (Kent Or Similar Approved)	50									
1.35.13.2.		20MM Kent Tailpiece HZ012 (Kent Or Similar Approved)	160									
1.35.13.3.		40MM Kent Tailpiece HZ005 (Kent Or Similar Approved)	20									
<b>1.36.</b>	<b>HDPE Compression Fittings</b>											
<b>1.36.1.</b>	<b>Male Plasson Adaptors</b>											
1.36.1.1.	10A001	20mm x 15mm	80				Each					
1.36.1.2.	10A002	20mm x 22mm	200				Each					

SIGNATURE		NAME (PRINT)		DATE	
CAPACITY		NAME OF FIRM			



	OM Stock code	Product	Est. Qty.	Does your offer comply with the specifications?		Lead Time	Unit	Manufacturer	Kleinmond Price Per Unit (Incl. VAT)	Hermanus Price Per Unit (Incl. VAT)	Gansbaai Price Per Unit (Incl. VAT)	Indicate Escalation type: ROE (R) Industry (I) CPIX (C)
				Yes	No							
1.36.1.3.	10A004	25mm x 15mm	10				Each					
1.36.1.4.	10A005	25mm x 22mm	500				Each					
1.36.1.5.	10A006	25mm x 25mm	20				Each					
1.36.1.6.	10A007	32mm x 22mm	20				Each					
1.36.1.7.	10A008	40mm x 40mm	5				Each					
1.36.1.8.	10A010	50mm x 40mm	5				Each					
1.36.1.9.	10A009	50mm x 50mm	5				Each					
<b>1.36.2.</b>	<b>Female Adaptors</b>											
1.36.2.1.	Non Stock	20mm x 15mm	1				Each					
1.36.2.2.	10A002	20mm x 22mm	100				Each					
1.36.2.3.	Non Stock	25mm x 15mm	1				Each					
1.36.2.4.	Non Stock	25mm x 22mm	1				Each					
1.36.2.5.	Non Stock	25mm x 25mm	1				Each					
1.36.2.6.	Non Stock	32mm x 22mm	1				Each					
1.36.2.7.	Non Stock	40mm x 40mm	1				Each					
1.36.2.8.	Non Stock	50mm x 50mm	1				Each					
1.36.2.9.	Non Stock	50mm x 40mm	1				Each					
<b>1.36.3.</b>	<b>Plasson Couplings</b>											
1.36.3.1.	Non Stock	15mm	1				Each					
1.36.3.2.	10C020	20mm	40				Each					
1.36.3.3.	10C021	25mm	150				Each					
1.36.3.4.	Non Stock	32mm	1				Each					
1.36.3.5.	Non Stock	40mm	1				Each					
1.36.3.6.	10C022	50mm	10				Each					

SIGNATURE	NAME (PRINT)	DATE
CAPACITY	NAME OF FIRM	



	OM Stock code	Product	Est. Qty.	Does your offer comply with the specifications?		Lead Time	Unit	Manufacturer	Kleinmond Price Per Unit (Incl. VAT)	Hermanus Price Per Unit (Incl. VAT)	Gansbaai Price Per Unit (Incl. VAT)	Indicate Escalation type: ROE (R) Industry (I) CPIX (C)
				Yes	No							
1.37.	<b>Reducing Elbows / Reducers</b>											
1.37.1.	<b>Male Plasson Reducing Elbows</b>											
1.37.1.1.	10E019	25mm x 15mm	10				Each					
1.37.1.2.	10E020	25mm x 22mm	110				Each					
1.37.2.	<b>Female Plasson Reducing Elbows</b>											
1.37.2.1.	Non Stock	25mm x 15mm	1				Each					
1.37.2.2.	Non Stock	25mm x 22mm	1				Each					
1.37.3.	<b>Plasson Reducers: Male / Female Thread</b>											
1.37.3.1.	Non Stock	25mm x 15mm	1				Each					
1.37.3.2.	Non Stock	25mm x 22mm	1				Each					
1.37.4.	<b>Plasson Stop Ends</b>											
1.37.4.1.	Non Stock	15mm	1				Each					
1.37.4.2.	Non Stock	22mm	1				Each					
1.37.4.3.	10S003	25mm	15				Each					
1.37.4.4.	Non Stock	32mm	1				Each					
1.37.4.5.	Non Stock	40mm	1				Each					
1.37.4.6.	Non Stock	50mm	1				Each					
1.38.	<b>Plasson Tees</b>											
1.38.1.	<b>90° Equal Tees</b>											
1.38.1.1.	Non Stock	15mm	1				Each					
1.38.1.2.	10T320	22mm	10				Each					
1.38.1.3.	10t321	25mm	50				Each					
1.38.1.4.	Non Stock	32mm	1				Each					
1.38.1.5.	Non Stock	40mm	1				Each					
1.38.1.6.	Non Stock	50mm	1				Each					

SIGNATURE	NAME (PRINT)	DATE
CAPACITY	NAME OF FIRM	



	OM Stock code	Product	Est. Qty.	Does your offer comply with the specifications?		Lead Time	Unit	Manufacturer	Kleinmond Price Per Unit (Incl. VAT)	Hermanus Price Per Unit (Incl. VAT)	Gansbaai Price Per Unit (Incl. VAT)	Indicate Escalation type: ROE (R) Industry (I) CPIX (C)
				Yes	No							
<b>1.38.2.</b>	<b>Threaded Female Off-Take</b>											
1.38.2.1.	Non Stock	15mm	1				Each					
1.38.2.2.	Non Stock	22mm	1				Each					
1.38.2.3.	Non Stock	25mm	1				Each					
1.38.2.4.	Non Stock	32mm	1				Each					
1.38.2.5.	Non Stock	40mm	1				Each					
1.38.2.6.	Non Stock	50mm	1				Each					
<b>1.38.3.</b>	<b>Threaded Male Off-Take</b>											
1.38.3.1.	Non Stock	15mm	1				Each					
1.38.3.2.	Non Stock	22mm	1				Each					
1.38.3.3.	Non Stock	25mm	1				Each					
1.38.3.4.	Non Stock	32mm	1				Each					
1.38.3.5.	Non Stock	40mm	1				Each					
1.38.3.6.	Non Stock	50mm	1				Each					
<b>1.39.</b>	<b>HDPE Pipe</b>											
<b>1.39.1.</b>	<b>Class 12 (Black)</b>											
1.39.1.1.	10P020	25mm	900				Meter					
1.39.1.2.	Non Stock	32mm	100				Meter					
1.39.1.3.	Non Stock	40mm	100				Meter					
<b>1.39.2.</b>	<b>Poly Cop Pipe Class 16</b>											
1.39.2.1.	10P010	15mm	1600				Meter					
1.39.2.2.	10P011	22mm	3500				Meter					
1.39.2.3.	10P012	25mm	100				Meter					
1.39.2.4.	10P013	42mm	200				Meter					

SIGNATURE	NAME (PRINT)	DATE
CAPACITY	NAME OF FIRM	



	OM Stock code	Product	Est. Qty.	Does your offer comply with the specifications?		Lead Time	Unit	Manufacturer	Kleinmond Price Per Unit (Incl. VAT)	Hermanus Price Per Unit (Incl. VAT)	Gansbaai Price Per Unit (Incl. VAT)	Indicate Escalation type: ROE (R) Industry (I) CPIX (C)
				Yes	No							
1.40.	<b>Saddle: Poly16 Plus Clamp saddle (PN16)</b>											
1.40.1.	11S200	50MMX20MM										
1.40.2.	11S201	63mmx20mm										
1.40.3.	11S202	75mmx20mm										
1.40.4.	11S203	90mmx20mm										
1.40.5.	11S204	110mmx20mm										
1.40.6.	11S206	160mmx20mm										
1.40.7.	Non Stock	200mmx20mm										
1.40.8.	Non Stock	250mmx20mm										
1.40.9.	Non Stock	300mmx20mm										
1.41.	<b>General</b>											
1.41.1.	10T400	Thread tape	2800				Each					
1.41.2.	11D001	Denso paste per 500gram	5				Each					
1.41.3.	11D002	Denso tape – 100mm	40				Roll					
1.41.4.	20P100	PVC-U special cement for rigid PVC fittings and pipes (500ml). Must comply with DIN 16970 (German) and BS4346-3 (British ) specifications	45				500ml					
1.41.5.	10P100	15mm Galvanized MC Hollow Plugs	5				Each					
1.41.6.	10P101	20mm Galvanized MC Hollow Plugs	5				Each					
1.41.7.	11B201	M16 x 55mm HEX Galvanized Bolts & Nuts Full Thread	30				Each					
1.41.8.	11B202	M16 x 65mm HEX Galvanized Bolts & Nuts Full Thread	30				Each					
1.41.9.	11B201	M16 x 90mm HEX Galvanized Bolts & Nuts Half Thread	30				Each					
1.41.10.	11T001	12 x 88mm Brass T-Bolts And Nuts Full Thread	5				Each					

SIGNATURE		NAME (PRINT)		DATE	
CAPACITY			NAME OF FIRM		



	OM Stock code	Product	Est. Qty.	Does your offer comply with the specifications?		Lead Time	Unit	Manufacturer	Kleinmond Price Per Unit (Incl. VAT)	Hermanus Price Per Unit (Incl. VAT)	Gansbaai Price Per Unit (Incl. VAT)	Indicate Escalation type: ROE (R) Industry (I) CPIX (C)
				Yes	No							
1.41.11.	11T002	16 x 85mm Brass T-Bolts And Nuts Full Thread	5				Each					
1.42.	<b>Subsoil Poly-drainage Pipes / 6m</b>											
1.42.1.	30P001	160mm	10				Length					
1.43.	<b>STORM-WATER PIPES HDPE</b>											
1.43.1.	<b>Spigot and Socket High-Density Polyethylene Resin Structured Wall Storm-Water Pipes 4 kN</b>											
1.43.1.1.	30P200	300mm Ø (diameter) x 6m	10				Length					
1.43.1.2.	30P201	450mm Ø (diameter) x 6m	10				Length					
1.43.1.3.	Non Stock	600mm Ø (diameter) x 6m					Length					
1.44.	<b>STORM-WATER PIPES CONCRETE</b>											
1.45.	<b>Concrete Spigot and socket pipe – SANS 677 – Class 100D</b>											
1.45.1.	Non Stock	300mm Ø (diameter) x 2.4m					Length					
1.45.2.	Non Stock	375mm Ø (diameter) x 2.4m					Length					
1.45.3.	Non Stock	450mm Ø (diameter) x 2.4m					Length					
1.45.4.	Non Stock	525mm Ø (diameter) x 2.4m					Length					
1.45.5.	Non Stock	600mm Ø (diameter) x 2.4m					Length					

SIGNATURE		NAME (PRINT)		DATE	
CAPACITY			NAME OF FIRM		



	OM Stock code	Product	Est. Qty.	Does your offer comply with the specifications?		Lead Time	Unit	Manufacturer	Kleinmond Price Per Unit (Incl. VAT)	Hermanus Price Per Unit (Incl. VAT)	Gansbaai Price Per Unit (Incl. VAT)	Indicate Escalation type: ROE (R) Industry (I) CPIX (C)
				Yes	No							
<b>2.</b>	<b>SECTION 2: WATER METERS</b>											
<b>2.1.</b>	<b>Standard Plastic Water Meter In Box (Kent Or Similar)</b>											
2.1.1.	Non Stock	15mm	1				Each					
2.1.2.	10W004	20mm	300				Each					
2.1.3.	Non Stock	25mm	1				Each					
2.1.4.	Non Stock	Key for Water Meter Box	100				Each					
<b>2.2.</b>	<b>Above Ground Meter Box (Kent Or Similar)</b>											
2.2.1.	10W001	15mm	100				Each					
<b>2.3.</b>	<b>Water Management Device Meter (Kent Or Similar)</b>											
2.3.1.	10W0015	15mm	100				Each					
<b>2.4.</b>	<b>Domestic Water Meters (Brass Body) Kent Or Similar (Optima)</b>											
2.4.1.	10W006	15mm	10				Each					
2.4.2.	Non Stock	20mm	1				Each					
2.4.3.	10W009	25mm	2				Each					
<b>2.5.</b>	<b>Domestic Water Meters (PVC Body) – Kent Or Similar</b>											
2.5.1.	10W002	15mm	60				Each					
2.5.2.	10W003	20mm	75				Each					
2.5.3.	Non Stock	25mm	1				Each					
<b>2.6.</b>	<b>Multi-Jet Water Meters (Kent Or Similar)</b>											
2.6.1.	10W005	15mm	30				Each					
2.6.2.	Non Stock	20mm	1				Each					

SIGNATURE	NAME (PRINT)	DATE
CAPACITY	NAME OF FIRM	



	OM Stock code	Product	Est. Qty.	Does your offer comply with the specifications?		Lead Time	Unit	Manufacturer	Kleinmond Price Per Unit (Incl. VAT)	Hermanus Price Per Unit (Incl. VAT)	Gansbaai Price Per Unit (Incl. VAT)	Indicate Escalation type: ROE (R) Industry (I) CPIX (C)
				Yes	No							
2.6.3.	Non Stock	25mm	1				Each					
2.6.4.	10W010	40mm	10				Each					
2.7.	<b>Combination Water Meters (Kent Or Similar)</b>											
2.7.1.	10W100	50mm	1				Each					
2.7.2.	10W101	80mm	2				Each					
2.7.3.	10W014	100mm	2				Each					
2.7.4.	Non Stock	150mm	0				Each					
2.8.	<b>Bulk Water Meters (Kent Or Similar)</b>											
2.8.1.	Non Stock	40mm	0				Each					
2.8.2.	10W011	50mm	2				Each					
2.8.3.	10W012	80mm	2				Each					
2.8.4.	10W013	100mm	2				Each					
2.9.	<b>In-Line Strainers for water meters</b>											
2.9.1.	Non Stock	40mm	0				Each					
2.9.2.	Non Stock	50mm	0				Each					
2.9.3.	Non Stock	80mm	0				Each					
2.9.4.	Non Stock	100mm	0				Each					
2.9.5.	Non Stock	150mm	0				Each					

SIGNATURE		NAME (PRINT)		DATE	
CAPACITY			NAME OF FIRM		



	OM Stock code	Product	Est. Qty.	Does your offer comply with the specifications?		Lead Time	Unit	Manufacturer	Kleinmond Price Per Unit (Incl. VAT)	Hermanus Price Per Unit (Incl. VAT)	Gansbaai Price Per Unit (Incl. VAT)	Indicate Escalation type: ROE (R) Industry (I) CPIX (C)
				Yes	No							
3.	<b>SECTION 3: POLYMER CONCRETE MANHOLE COVERS AND FRAMES</b>											
3.1.	<b>Polymer Manhole Covers &amp; Frames</b>											
3.1.1.	Non Stock	Type 2A Circular Manhole Cover & Frame	0				Each					
3.1.2.	30M004	Type 2B Circular Manhole Cover & Frame	15									
3.1.3.	30B001	Type 3A Belltobie	45				Each					
3.1.4.	Non Stock	Type 4A Circular Manhole Cover & Frame					Each					
3.1.5.	30H001	Type 5 Rectangular Hydrant Box	30				Each					
3.1.6.	30G001	Table 6 Rectangular Gully Grating & Frame	30				Each					
3.1.7.	30M001	Type 14B 450 x 450 Square Manhole Cover & Frame	20				Each					
3.1.8.	30M002	Type 9D 600 x 450 Rectangular Manhole Cover & Frame	45				Each					
3.1.9.	30M003	Type 9E 900 x 600 Rectangular Manhole Cover & Frame	30				Each					
3.2.	<b>Polymer Replacement Covers Only</b>											
3.2.1.	Non Stock	Type 2A Circular Replacement Cover	0				Each					
3.2.2.	30M100	Type 2B Circular Replacement Cover	2									
3.2.3.	Non Stock	Type 4A Circular Replacement Cover	0				Each					
3.2.4.		Table 6 Rectangular Replacement Gully Grating	35				Each					
3.2.5.		Type 9D 600 x 450 Rectangular Manhole Replacement Cover	3				Each					
3.2.6.		Type 9E 900 x 600 Rectangular Manhole Replacement Cover	6				Each					
3.2.7.		Type 14B 450 x 450 Square Manhole Replacement Cover	1				Each					

SIGNATURE		NAME (PRINT)		DATE	
CAPACITY			NAME OF FIRM		



	OM Stock code	Product	Est. Qty.	Does your offer comply with the specifications		Lead Time	Unit	Manufacturer	Kleinmond Price Per Unit (Incl. VAT)	Hermanus Price Per Unit (Incl. VAT)	Gansbaai Price Per Unit (Incl. VAT)	Indicate Escalation type: ROE (R) Industry (I) CPIX (c)
				Yes	No							
<b>4.</b>	<b>SECTION 4: NON STOCK - SEWER MAINS AND GENERAL PLUMBING SPARES &amp; TOOLS</b>											
4.1.	Non Stock	Ball Float Plas/Orange 110x8mm	1									
4.2.	Non Stock	Basin Plastic Christy + Bracket	1									
4.3.	Non Stock	Basin: Beta Basin Flair Commercial	1									
4.4.	Non Stock	Basinwaste 32 X 85 Unslotted	1									
4.5.	Non Stock	Bath Sink Waste With Plug	1									
4.6.	Non Stock	Bolt Set Fixg: 8448zo #1500212	1									
4.7.	Non Stock	Chain Basin W/Stay Cp	1									
4.8.	Non Stock	Cistern Dutton Fp16a Elf Mechanism	1									
4.9.	Non Stock	Cistern Inside Beta LI Fp15c	1									
4.10.	Non Stock	Cistern Outlet 1 3/4 Cp Hand	1									
4.11.	Non Stock	Cistern White Elf LI 9l W/Ball	1									
4.12.	Non Stock	Extended Conn 32m Tube	1									
4.13.	Non Stock	Flexible Braided Connector	1									
4.14.	Non Stock	Flush: Mw2 Dual Flush Ext2" + Bibo Adapter	1									
4.15.	Non Stock	Flush: Dutton Fp10f Supa Flush Valve (Or Compatible)	1									
4.16.	Non Stock	Geyser Element Spiral Incalloy 3kw	1									
4.17.	Non Stock	Geyser Gasket Flange Mk2 Flg337	1									
4.18.	Non Stock	Geyser Thermostat Kwiktherm 11 20amps Th208	1									
4.19.	Non Stock	Head Part Start Type 15mm	1									
4.20.	Non Stock	Head Part: S-Km9.201b Head Part Cp Pushtap	1									
4.21.	Non Stock	Hose Clamp Galv G32w 14 – 27mm	1									
4.22.	Non Stock	Inlet Dutton Fp3 Kleenflo Side Inlet (Or compatible)	1									

SIGNATURE		NAME (PRINT)		DATE	
CAPACITY			NAME OF FIRM		



	OM Stock code	Product	Est. Qty.	Does your offer comply with the specifications		Lead Time	Unit	Manufacturer	Kleinmond Price Per Unit (Incl. VAT)	Hermanus Price Per Unit (Incl. VAT)	Gansbaai Price Per Unit (Incl. VAT)	Indicate Escalation type: ROE (R) Industry (I) CPIX (c)
				Yes	No							
4.23.	Non Stock	Insert For Cobra Pipe 15mm	1									
4.24.	Non Stock	Insert For Cobra Pipe 22mm	1									
4.25.	Non Stock	Nut: Brass Backnut 15mm	1									
4.26.	Non Stock	Pan Easy Flush 2.5l Capacity	1									
4.27.	Non Stock	Pan Vaal Toilet Suite Hibiscus	1									
4.28.	Non Stock	Pan White Protea Low Level Keradn	1									
4.29.	Non Stock	Pvc Pipe Above Ground 110mm	1									
4.30.	Non Stock	Pvc Pipe Underground 110mm	1									
4.31.	Non Stock	Pvc Pipe White E-Spec 40mmx6	1									
4.32.	Non Stock	Pvc Pipe White E-Spec 50mmx6	1									
4.33.	Non Stock	Pvc Ug Double Socket 110mm	1									
4.34.	Non Stock	Pvc Ug Socket Kimberley 110mm	1									
4.35.	Non Stock	Pvc Ug Single Socket 110mm	1									
4.36.	Non Stock	Pvc Ug Ribbed Bend 87.5', Inspection Eye 110mm,	1									
4.37.	Non Stock	Pvc Ug Ribbed Bend 22.5', 110mm,	1									
4.38.	Non Stock	Pvc Ug Bend 135', 110mm	1									
4.39.	Non Stock	Pvc Ug Bend 135', Inspection Eye 110mm	1									
4.40.	Non Stock	Pvc Ug Bend 90' 110mm	1									
4.41.	Non Stock	Pvc Ug Ribbed R/H Junction 45', Inspection Eye 110mm,	1									
4.42.	Non Stock	Pvc Ug Ribbed L/H Junction 45', Inspection Eye, 110mm,	1									
4.43.	Non Stock	Pvc Ug Ribbed Junction 45' 110mm	1									
4.44.	Non Stock	Pvc Ug Inspection Pipe, 110mm	1									
4.45.	Non Stock	Pvc Ug Junction 45°, 110mm,	1									

SIGNATURE		NAME (PRINT)		DATE	
CAPACITY			NAME OF FIRM		



	OM Stock code	Product	Est. Qty.	Does your offer comply with the specifications		Lead Time	Unit	Manufacturer	Kleinmond Price Per Unit (Incl. VAT)	Hermanus Price Per Unit (Incl. VAT)	Gansbaai Price Per Unit (Incl. VAT)	Indicate Escalation type: ROE (R) Industry (I) CPIX (c)
				Yes	No							
4.46.	Non Stock	Pvc Ug Junction 45°, R/H, Inspection Eye, 110mm	1									
4.47.	Non Stock	Pvc Ug Junction 45°, L/H, Inspection Eye, 110mm	1									
4.48.	Non Stock	Pvc Ug Junction 90°, 110mm,	1									
4.49.	Non Stock	Pvc Ug Junction 45°,	1									
4.50.	Non Stock	Pvc Ug Adaptor Pvc/Ew Female, 110mm,	1									
4.51.	Non Stock	Pvc Ug Adaptor Pvc/Ew Male, 110mm,	1									
4.52.	Non Stock	Pvc Rodding Eye 45 Deg X 110mm	1									
4.53.	Non Stock	Pvc Stop End 110mm Female	1									
4.54.	Non Stock	Pvc Stop End 110mm Male	1									
4.55.	Non Stock	Pvc Gully Head & Grate, 150mm,	1									
4.56.	Non Stock	Pvc Junction 95° Double Reducing Plain, 110 X 50mm	1									
4.57.	Non Stock	Pvc Junction 95° Double Reducing, Inspection Eye, 110 X 50mm	1									
4.58.	Non Stock	Pvc Junction 95° Single Reducing Plain, 110 X 50mm	1									
4.59.	Non Stock	Pvc Junction 95° Single Reducing, Inspection Eye Heel, 110 X 50mm	1									
4.60.	Non Stock	Pvc Bend 90° Plain, 110mm	1									
4.61.	Non Stock	Pvc Bend Bend 90° Inspection Eye Heel,	1									
4.62.	Non Stock	Pvc Bend Vent Horn Inspection Eye Heel 110mm	1									
4.63.	Non Stock	Pvc Pan Connector Foxyfit	1									
4.64.	Non Stock	Pvc Pan Connector Straight Collar 110	1									
4.65.	Non Stock	Pvc Pan Connector: Hepworth Flexible Pan Connector	1									
4.66.	Non Stock	Pvcpan Kwickpan Connector,	1									
4.67.	Non Stock	Pvc Waste Access Cap 1 1/4 Bsp	1									

SIGNATURE	NAME (PRINT)	DATE
CAPACITY	NAME OF FIRM	



	OM Stock code	Product	Est. Qty.	Does your offer comply with the specifications		Lead Time	Unit	Manufacturer	Kleinmond Price Per Unit (Incl. VAT)	Hermanus Price Per Unit (Incl. VAT)	Gansbaai Price Per Unit (Incl. VAT)	Indicate Escalation type: ROE (R) Industry (I) CPIX (c)
				Yes	No							
4.68.	Non Stock	Pvc Waste Access Cap 1 1/5 Bsp	1									
4.69.	Non Stock	Pvc Watse Stopend Female 40mm	1									
4.70.	Non Stock	Pvc Watse Stopend Female 50mm	1									
4.71.	Non Stock	Pvc Watse Reducer Socket 50mm X 40mm	1									
4.72.	Non Stock	Pvc Waste Socket 40mm	1									
4.73.	Non Stock	Pvc Waste Socket 50mm	1									
4.74.	Non Stock	Pvc Watse Strap On Boss 110mm X 50mm	1									
4.75.	Non Stock	Pvc Holder Bat Or Hilti Nail 40mm	1									
4.76.	Non Stock	Pvc Holder Bat Or Hilti Nail 50mm	1									
4.77.	Non Stock	Pvc Waste Junction Plain 40mm X 87.5'	1									
4.78.	Non Stock	Pvc Waste Junction Plain 50mm X 87.5'	1									
4.79.	Non Stock	Pvc Waste Junction Inspection 40mm X 87.5'	1									
4.80.	Non Stock	Pvc Waste Junction Inspection 50mm X 87.5'	1									
4.81.	Non Stock	Pvc Waste Junction Plain 40mm X 135' Or 45'	1									
4.82.	Non Stock	Pvc Waste Junction Plain 50mm X 135' Or 45'	1									
4.83.	Non Stock	Pvc Waste Junction Inspection 40mm X 135' Or 45'	1									
4.84.	Non Stock	Pvc Waste Junction Inspection 50mm X 135' Or 45'	1									
4.85.	Non Stock	Pvc Waste Bend 40mm X 135' Or 45'	1									
4.86.	Non Stock	Pvc Waste Bend 50mm X 135' Or 45'	1									
4.87.	Non Stock	Pvc Waste Bend Inspection 40mm X 135' Or 45'	1									
4.88.	Non Stock	Pvc Waste Bend Inspection 50mm X 135 Or 45'	1									
4.89.	Non Stock	Pvc Waste Short Bend 40mm X 135' Or 45'	1									
4.90.	Non Stock	Pvc Waste Short Bend 50mm X 135' Or 45'	1									

SIGNATURE		NAME (PRINT)		DATE	
CAPACITY			NAME OF FIRM		



	OM Stock code	Product	Est. Qty.	Does your offer comply with the specifications		Lead Time	Unit	Manufacturer	Kleinmond Price Per Unit (Incl. VAT)	Hermanus Price Per Unit (Incl. VAT)	Gansbaai Price Per Unit (Incl. VAT)	Indicate Escalation type: ROE (R) Industry (I) CPIX (c)
				Yes	No							
4.91.	Non Stock	Pvc Waste Short Bend Inspection 40mm X 135' Or 45'	1									
4.92.	Non Stock	Pvc Waste Short Bend Inspection 50mm X 135 Or 45'	1									
4.93.	Non Stock	Pvc Waste Bend Plain 40mm X 90'	1									
4.94.	Non Stock	Pvc Waste Bend Plain 50mm X 90'	1									
4.95.	Non Stock	Pvc Waste Bend Inspection 40mm X 90'	1									
4.96.	Non Stock	Pvc Waste Bend Inspection 50mm X 90'	1									
4.97.	Non Stock	Pvc Waste Short Bend Plain 40mm X 90'	1									
4.98.	Non Stock	Pvc Waste Short Bend Plain 50mm X 90'	1									
4.99.	Non Stock	Pvc Waste Short Bend Inspection 40mm X 90'	1									
4.100.	Non Stock	Pvc Waste Short Bend Inspection 50mm X 90'	1									
4.101.	Non Stock	Pvc Vent Valve Two Way 50mm	1									
4.102.	Non Stock	Pvc Vent Valve One Way 50mm	1									
4.103.	Non Stock	Pvc Double Socket 50	1									
4.104.	Non Stock	Rubber: Bung Rubber For Flush Pipe	1									
4.105.	Non Stock	Rubber: Closet Cone Black / White Pvc.	1									
4.106.	Non Stock	Rubber: Closet Rubber Bung	1									
4.107.	Non Stock	Shower Head Aqua Shell (Or Similar Approved)	1									
4.108.	Non Stock	Standpipe Polyprop 15mm With Wallplate Elbow 950	1									
4.109.	Non Stock	Tap Mixer: Aspen Lite Wall Sink Mixer	1									
4.110.	Non Stock	Tap Mixer: Sink Mix Er Solo	1									
4.111.	Non Stock	Tap Pillar 1/2 Cp	1									
4.112.	Non Stock	Tap Stopcock Under Wall 15mm	1									
4.113.	Non Stock	Tap: Km2.302-15 Pushbutton S/Tap 15	1									

SIGNATURE		NAME (PRINT)		DATE	
CAPACITY			NAME OF FIRM		



	OM Stock code	Product	Est. Qty.	Does your offer comply with the specifications		Lead Time	Unit	Manufacturer	Kleinmond Price Per Unit (Incl. VAT)	Hermanus Price Per Unit (Incl. VAT)	Gansbaai Price Per Unit (Incl. VAT)	Indicate Escalation type: ROE (R) Industry (I) CPIX (c)
				Yes	No							
4.114.	Non Stock	Toilet Seat Dutton Elf 82 Or Similar Approved	1									
4.115.	Non Stock	Toilet Seat White Wooden Seat	1									
4.116.	Non Stock	Trap: Pvc Basin P - Trap 32mm	1									
4.117.	Non Stock	Trap: Pvc Basin P – Trap 40mm	1									
4.118.	Non Stock	Trap: Pvc Bottle Trap 40 X 40mm	1									
4.119.	Non Stock	Trap: Pvc Double Bowl Sink Combo Trap	1									
4.120.	Non Stock	Vacuum Breaker 20mm Cxc Hi-Flo	1									
4.121.	Non Stock	Valve: C- Fm 8.30 Piston Toilet Valve	1									
4.122.	Non Stock	Valve: Handle Or Arm Beta Valve	1									
4.123.	Non Stock	Valve: Hi-Flo Multi Valve 400kp Or 600kp	1									
4.124.	Non Stock	Washer Conical For 40mm Waste Trap	1									
4.125.	Non Stock	Washer For P-Trap 32mm	1									
4.126.	Non Stock	Washer For P-Trap 40mm	1									
4.127.	Non Stock	Washer: Fibre Washer 16x24x2mm	1									
4.128.	Non Stock	Washer: Fibre Washer 24.35x29x1.66mm	1									
4.129.	Non Stock	Waste Basin W/P Brass -32	1									
4.130.	Non Stock	Wax Bowl Ring White	1									
4.131.	<b>'O' Ring (Replacement)</b>											
4.131.1.	Non Stock	15epr 15	1									
4.131.2.	Non Stock	22epr 22	1									
4.131.3.	Non Stock	28epr 28	1									
4.132.	<b>Collet Cover</b>											
4.132.1.	Non Stock	PM1915R 15mm	1									
4.132.2.	Non Stock	PM1915B 15mm	1									
4.132.3.	Non Stock	PM1922R 22mm	1									

SIGNATURE	NAME (PRINT)	DATE
CAPACITY	NAME OF FIRM	



	OM Stock code	Product	Est. Qty.	Does your offer comply with the specifications		Lead Time	Unit	Manufacturer	Kleinmond Price Per Unit (Incl. VAT)	Hermanus Price Per Unit (Incl. VAT)	Gansbaai Price Per Unit (Incl. VAT)	Indicate Escalation type: ROE (R) Industry (I) CPIX (c)
				Yes	No							
4.132.4.	Non Stock	PM1922B 22mm	1									
4.133.	<b>Collet Locking Clip</b>											
4.133.1.	Non Stock	CM1815R 15mm	1									
4.133.2.	Non Stock	CM1815B 15mm	1									
4.133.3.	Non Stock	CM1815W 15mm	1									
4.133.4.	Non Stock	CM1822R 22mm	1									
4.133.5.	Non Stock	CM1822B 22mm	1									
4.133.6.	Non Stock	CM1822W 22mm	1									
4.134.	<b>Collets (Replacement)</b>											
4.134.1.	Non Stock	PXC15 15mm	1									
4.134.2.	Non Stock	PXC22 22mm	1									
4.134.3.	Non Stock	PXC28 28mm	1									
4.134.4.	Non Stock	<b>Connector Conversion</b>	1									
4.134.5.	Non Stock	Nc471 15mm X 1/2" Id(connects imperial to metric pipe)	1									
4.135.	<b>Connector Equal Straight</b>											
4.135.1.	Non Stock	Pem0415w 15mm	1									
4.135.2.	Non Stock	Pem0422w 22mm	1									
4.135.3.	Non Stock	Pem0428w 28mm	1									
4.136.	<b>Connector Reducing Straight -</b>											
4.136.1.	Non Stock	PEM202215W 22mm X 15mm	1									
4.137.	<b>Connector Slip</b>											
4.137.1.	Non Stock	CM-SC-15S 15mm	1									
4.138.	<b>Coupler Male - Straight</b>											
4.138.1.	Non Stock	Nc2556 15mmx 1/2"	1									

SIGNATURE		NAME (PRINT)		DATE	
CAPACITY			NAME OF FIRM		



	OM Stock code	Product	Est. Qty.	Does your offer comply with the specifications		Lead Time	Unit	Manufacturer	Kleinmond Price Per Unit (Incl. VAT)	Hermanus Price Per Unit (Incl. VAT)	Gansbaai Price Per Unit (Incl. VAT)	Indicate Escalation type: ROE (R) Industry (I) CPIX (c)
				Yes	No							
4.138.2.	Non Stock	Nc2557 22mm X ¾"	1									
4.139.	<b>Elbow Equal</b>											
4.139.1.	Non Stock	Pem0315w 15mm	1									
4.139.2.	Non Stock	Pem0322w 22mm	1									
4.139.3.	Non Stock	Pem0328w 28mm	1									
4.140.	<b>Elbow Reducing</b>											
4.140.1.	Non Stock	PEM212215W 22mm X 15mm	1									
4.141.	<b>Elbow Stem (Swivel Action)</b>											
4.141.1.	Non Stock	PEM221515W 15mm X 15mm	1									
4.141.2.	Non Stock	PEM222222W 22mm X 22mm	1									
4.141.3.	Non Stock	<b>Elbow Wall Plate</b>	1									
4.141.4.	Non Stock	15pwb 15mm X ½"	1									
4.142.	<b>Insert Pipe Super Seal</b>											
4.142.1.	Non Stock	STS15 15mm	1									
4.142.2.	Non Stock	STS22 22mm	1									
4.142.3.	Non Stock	STS28 28mm	1									
4.143.	<b>Insert Standard pipe insert must be used when connecting Speedfit pipe with compression (Conex) fittings.</b>											
4.143.1.	Non Stock	TSM15N 15mm	1									
4.143.2.	Non Stock	TSM22N 22mm	1									
4.143.3.	Non Stock	TSM28N 28mm	1									
4.144.	<b>Pipe Barrier Speedpex (Straight Lengths)</b>											
4.144.1.	Non Stock	15BPEX-20X2L 15mm X 2	1									
4.144.2.	Non Stock	15BPEX-20X5L 15mm X 5	1									
4.144.3.	Non Stock	22BPEX-20X2L 22mm X 2	1									

SIGNATURE		NAME (PRINT)		DATE	
CAPACITY			NAME OF FIRM		



	OM Stock code	Product	Est. Qty.	Does your offer comply with the specifications		Lead Time	Unit	Manufacturer	Kleinmond Price Per Unit (Incl. VAT)	Hermanus Price Per Unit (Incl. VAT)	Gansbaai Price Per Unit (Incl. VAT)	Indicate Escalation type: ROE (R) Industry (I) CPIX (c)
				Yes	No							
4.144.4.	Non Stock	22BPEX-20X5L 22mm X 5	1									
4.144.5.	Non Stock	28BPEX-10X6L 28mm X 6	1									
4.145.	<b>Pipe Barrier Speedpex (Coils)</b>											
4.145.1.	Non Stock	15BPEX-50C 15mmx 50m	1									
4.145.2.	Non Stock	22BPEX-50C 22mm X 50m	1									
4.146.	<b>Reducer - Stem</b>											
4.146.1.	Non Stock	PEM062215W 22mm X 15mm	1									
4.146.2.	Non Stock	PEM062815W 28mm X 15mm	1									
4.146.3.	Non Stock	PEM062822W 28mm X 22mm	1									
4.147.	<b>Speedfit X Hand Tighten Nut</b>											
4.148.	<b>300mm Long</b>											
4.148.1.	Non Stock	Pfix15 15mm X 1/2"	1									
4.148.2.	Non Stock	Pfix16 15mm X 3/4"	1									
4.148.3.	Non Stock	Pfix22 22mm X 3/4"	1									
4.149.	<b>500mm Long</b>											
4.149.1.	Non Stock	Pfix18 15mm X 1/2"	1									
4.149.2.	Non Stock	Pfix19 22mm X 3/4"	1									
4.149.3.	Non Stock	Wfix20 15mm X 3/4"	1									
4.150.	<b>Speedfit X Hand Tighten Nut With Service Valve</b>											
4.150.1.	<b>300mm Long</b>											
4.150.1.1.	Non Stock	Pfix37-H 15mm X 1/2"	1									
4.150.1.2.	Non Stock	Pfix39-H 22mm X 3/4"	1									
4.151.	<b>Springs Bending</b>											
4.151.1.	Non Stock	SFA-IBS15 15mm INTERNAL	1									
4.151.2.	Non Stock	SFA-IBS22 22mm INTERNAL	1									

SIGNATURE	NAME (PRINT)	DATE
CAPACITY	NAME OF FIRM	



	OM Stock code	Product	Est. Qty.	Does your offer comply with the specifications		Lead Time	Unit	Manufacturer	Kleinmond Price Per Unit (Incl. VAT)	Hermanus Price Per Unit (Incl. VAT)	Gansbaai Price Per Unit (Incl. VAT)	Indicate Escalation type: ROE (R) Industry (I) CPIX (c)
				Yes	No							
4.151.3.	Non Stock	SFA-EBS15 15mm EXTERNAL	1									
4.152.	<b>Stop End</b>											
4.152.1.	Non Stock	Pse4615w 15mm	1									
4.152.2.	Non Stock	Pse4622w 22mm	1									
4.152.3.	Non Stock	Pse4628w 28mm	1									
4.153.	<b>Tap Connector Female - Coupler</b>											
4.153.1.	Non Stock	Pse3201w 15mm X 1/2"	1									
4.153.2.	Non Stock	Pse3203w 15mm X 3/4"	1									
4.153.3.	Non Stock	Pse3202w 22mm X 3/4"	1									
4.154.	<b>Tap Emergency Shut Off</b>											
4.154.1.	Non Stock	15ESOT 15mm	1									
4.155.	<b>Tap Washing Machine</b>											
4.155.1.	Non Stock	15apt 15mm X 3/4"	1									
4.156.	<b>Tee Equal</b>											
4.156.1.	Non Stock	Pem0215w 15mm	1									
4.156.2.	Non Stock	Pem0222w 22mm	1									
4.156.3.	Non Stock	Pem0228w 28mm	1									
4.157.	<b>Tee Reducing</b>											
4.157.1.	Non Stock	PEM3022AW 22mm X 22mm X 15mm	1									
4.157.2.	Non Stock	PEM3022BW 22mm X 15mm X 15mm	1									
4.157.3.	Non Stock	PEM3022CW 15mm X 15mm X 22mm	1									
4.157.4.	Non Stock	PEM3022DW 22mm X 15mm X 22mm	1									
4.157.5.	Non Stock	PEM3028AW 28mm X 28mm X 22mm	1									
4.157.6.	Non Stock	PEM3028BW 28mm X 22mm X 22mm	1									
4.157.7.	Non Stock	PEM3028DW 28mm X 22mm X 28mm	1									

SIGNATURE	NAME (PRINT)	DATE
CAPACITY	NAME OF FIRM	



	OM Stock code	Product	Est. Qty.	Does your offer comply with the specifications		Lead Time	Unit	Manufacturer	Kleinmond Price Per Unit (Incl. VAT)	Hermanus Price Per Unit (Incl. VAT)	Gansbaai Price Per Unit (Incl. VAT)	Indicate Escalation type: ROE (R) Industry (I) CPIX (c)
				Yes	No							
4.157.8.	Non Stock	PEM302815AW 28mm X 28mm X 15mm	1									
4.158.	<b>Tee Stem (Swivel Action)</b>											
4.158.1.	Non Stock	Pem532215w 22 X 22 X 15	1									
4.159.	<b>Valve Service Valve With Handle</b>											
4.159.1.	Non Stock	15SV-H 15mm	1									
4.159.2.	Non Stock	22SV-H 22mm	1									
4.160.	<b>Valve Stop (65° Maximum</b>											
4.160.1.	Non Stock	15STV 15mm	1									
4.160.2.	Non Stock	22STV 22mm	1									
4.161.	<b>Washer Thread (Replacement)</b>											
4.161.1.	Non Stock	1/2epw 1/2"	1									
4.161.2.	Non Stock	3/4epw 3/4"	1									
4.162.	<b>Plastic Taps, Plastic Compression Fittings</b>											
4.162.1.	Non Stock	Tap Hose Bib Tap20 - 3/4 Hose Union	1									
4.162.2.	Non Stock	Tap 15mm Plain Bib Tap Junior	1									
4.162.3.	Non Stock	Tap 20mm Plain Bib Tap Junior	1									
4.162.4.	Non Stock	Tap 15mm Hose Junior Bib Demand 3/4 Hose Union	1									
4.162.5.	Non Stock	Tap 15mm Plain Junior Bib Demand Tap	1									
4.162.6.	Non Stock	Tap 20mm Plain Junior Bib Demand Tap	1									
4.163.	<b>Stop Taps - 15mm</b>											
4.163.1.	Non Stock	Tap Stop Tap - Copper X Copper	1									
4.163.2.	Non Stock	Tap Stop Tap - Fusion X Fusion	1									
4.163.3.	Non Stock	Tap Stop Tap - Male X Male	1									
4.163.4.	Non Stock	Tap Stop Tap Demand - Copper X Copper	1									

SIGNATURE		NAME (PRINT)		DATE	
CAPACITY			NAME OF FIRM		



	OM Stock code	Product	Est. Qty.	Does your offer comply with the specifications		Lead Time	Unit	Manufacturer	Kleinmond Price Per Unit (Incl. VAT)	Hermanus Price Per Unit (Incl. VAT)	Gansbaai Price Per Unit (Incl. VAT)	Indicate Escalation type: ROE (R) Industry (I) CPIX (c)
				Yes	No							
4.163.5.	Non Stock	Tap Stop Tap Demand - Male X Male	1									
4.163.6.	Non Stock	Tap Hose Bib Tap20 - 3/4 Hose Union	1									
4.163.7.	Non Stock	Tap Stop Tap - Copper X Copper 20mm	1									
4.163.8.	Non Stock	Tap Stop Tap - Male X Male 20mm	1									
4.163.9.	Non Stock	Tap Standpipe Pillar Tap - 1/2 Bottom Inlet	1									
4.163.10.	Non Stock	Tap 15mm Hose Bib Tap Junior- 3/4 Hose Union	1									
4.163.11.	Non Stock	Tap 20mm Hose Bib Tap Junior- 3/4 Hose Union	1									
4.163.12.	Non Stock	Tap Standpipe Pillar Tap - 3/4 Bottom Inlet	1									
4.164.	<b>Compression Fittings 15mm</b>											
4.164.1.	Non Stock	Cap Nut 15mm	1									
4.164.2.	Non Stock	Copper X Stop-End	1									
4.164.3.	Non Stock	Coupling Copper X 20mm Male Coupler	1									
4.164.4.	Non Stock	Coupling Copper X Copper Coupler	1									
4.164.5.	Non Stock	Coupling Copper X Copper Slip Coupler	1									
4.164.6.	Non Stock	Coupling Copper X Female Coupler	1									
4.164.7.	Non Stock	Coupling Copper X Male Coupler	1									
4.164.8.	Non Stock	Elbow 90 Degree Copper X 20mm Male	1									
4.164.9.	Non Stock	Elbow 90 Degree Copper X Copper	1									
4.164.10.	Non Stock	Elbow 90 Degree Copper X Female	1									
4.164.11.	Non Stock	Elbow 90 Degree Copper X Male	1									
4.164.12.	Non Stock	Elbow 90 Degree Wall-Plate	1									
4.164.13.	Non Stock	Reducer 20 X 15	1									
4.164.14.	Non Stock	Tee Copper X Copper X Copper	1									
4.164.15.	Non Stock	Tee Copper X Female X Copper	1									

SIGNATURE		NAME (PRINT)		DATE	
CAPACITY			NAME OF FIRM		



	OM Stock code	Product	Est. Qty.	Does your offer comply with the specifications		Lead Time	Unit	Manufacturer	Kleinmond Price Per Unit (Incl. VAT)	Hermanus Price Per Unit (Incl. VAT)	Gansbaai Price Per Unit (Incl. VAT)	Indicate Escalation type: ROE (R) Industry (I) CPIX (c)
				Yes	No							
4.165.	<b>Cistern Spares</b>											
4.165.1.	Non Stock	Valve Arm 120mm	1									
4.165.2.	Non Stock	Valve Arm 162mm	1									
4.165.3.	Non Stock	Valve Arm 194mm	1									
4.165.4.	Non Stock	Valve Arm 267mm	1									
4.166.	<b>Tools</b>											
4.166.1.	Non Stock	Ratchet Spanner Set 15mm – 24mm	1									
4.166.2.	Non Stock	Spanner Loose Size 10 Ring Flat (Gedore Or Similar Approved)	1									
4.166.3.	Non Stock	Spanner Loose Size 11 Ring Flat (Gedore Or Similar Approved)	1									
4.166.4.	Non Stock	Spanner Loose Size 12 Ring Flat (Gedore Or Similar Approved)	1									
4.166.5.	Non Stock	Spanner Loose Size 13 Ring Flat (Gedore Or Similar Approved)	1									
4.166.6.	Non Stock	Spanner Loose Size 14 Ring Flat (Gedore Or Similar Approved)	1									
4.166.7.	Non Stock	Spanner Loose Size 19 Ring Flat (Gedore Or Similar Approved)	1									
4.166.8.	Non Stock	Spanner Loose Size 22 Ring Flat (Gedore Or Similar Approved)	1									
4.166.9.	Non Stock	Spanner Loose Size 24 Ring Flat (Gedore Or Similar Approved)	1									
4.166.10.	Non Stock	Spanner Loose Size 32 Ring Flat (Gedore Or Similar Approved)	1									
4.166.11.	Non Stock	Spanner Loose Size 34 Ring Flat (Gedore Or Similar Approved)	1									
4.166.12.	Non Stock	250mm Pipe Wrench	1									
4.166.13.	Non Stock	350mm Pipe Wrench	1									
4.166.14.	Non Stock	450mm Pipe Wrench	1									
4.166.15.	Non Stock	600mm Pipe Wrench	1									

SIGNATURE		NAME (PRINT)		DATE	
CAPACITY			NAME OF FIRM		

MUNISIPALITEIT



MUNICIPALITY

	OM Stock code	Product	Est. Qty.	Does your offer comply with the specifications		Lead Time	Unit	Manufacturer	Kleinmond Price Per Unit (Incl. VAT)	Hermanus Price Per Unit (Incl. VAT)	Gansbaai Price Per Unit (Incl. VAT)	Indicate Escalation type: ROE (R) Industry (I) CPIX (c)
				Yes	No							
4.166.16.	Non Stock	900mm Pipe Wrench	1									
4.166.17.	Non Stock	Red Knob Professional Hacksaw	1									
4.166.18.	Non Stock	Hammer: 450MM Ball Pein	1									
4.166.19.	Non Stock	Club Hammer 1.8 Kg Fibre Handle	1									
4.166.20.	Non Stock	Pliers: 250mm Water Pump	1									
4.166.21.	Non Stock	Pliers: 300mm Water Pump	1									
4.166.22.	Non Stock	Pliers: 250mm Fencing	1									
4.166.23.	Non Stock	Adjustable Wrench: 200mm	1									
4.166.24.	Non Stock	Adjustable Wrench: 250mm	1									
4.166.25.	Non Stock	Adjustable Wrench: 300mm	1									
4.166.26.	Non Stock	Measuring Tape; 10m Stanley Or Similar Approved (Where Brand Names Are Mentioned It Is Only To Show A Quality Standard)	1									
4.166.27.	Non Stock	Hatchet: 0.9kg Poly Handle Lasher Or Similar Approved	1									
4.166.28.	Non Stock	Chisel: 300mmx25mm	1									
4.166.29.	Non Stock	Hammer: Sledge Hammer 3.6kg	1									
4.166.30.	Non Stock	Spirit Level: 600mm	1									
4.166.31.	Non Stock	Pvc Pipe Cutter	1									
4.166.32.	Non Stock	Tube Cutter: 6 - 42mm	1									

SIGNATURE		NAME (PRINT)		DATE	
CAPACITY			NAME OF FIRM		



		Product	Est. Qty.	Does your Offer comply with the specifications		Lead Time	Unit	Manufacturer	Kleinmond Price Per Unit (Incl. VAT)	Hermanus Price Per Unit (Incl. VAT)	Gansbaai Price Per Unit (Incl. VAT)	Indicate Escalation type: ROE (R) Industry (I) CPIX (c)
				Yes	No							
5.	<b>SECTION 5: IRRIGATION</b>											
5.1.	<b>Compression Fittings</b>											
5.1.1.	<b>Elbow Male Combination (P X Mi)</b>											
5.1.1.1.	Non Stock	Ff 1190 - 13mm X 15mm ½" Bsp	1									
5.1.1.2.	Non Stock	Ff 1015 - 15mm X 15mm ½" Bsp	1									
5.1.1.3.	Non Stock	Ff 1192 - 15mm X 20mm ¾" Bsp	1									
5.1.1.4.	Non Stock	Ff 1016 - 20mm X 20mm ¾" Bsp	1									
5.1.1.5.	Non Stock	Ff 1017 - 20mm X 15mm ½" Bsp	1									
5.1.1.6.	Non Stock	Ff 1096 - 25mm X 15mm ½" Bsp	1									
5.1.1.7.	Non Stock	Ff 1100 - 25mm X 20mm ¾" Bsp	1									
5.1.1.8.	Non Stock	Ff 1350 - 25mm X 25mm 1" Bsp	1									
5.1.2.	<b>Elbow Reducing</b>											
5.1.2.1.	Non Stock	Ff 1256 - 20mm X 15mm	1									
5.1.3.	<b>Elbows</b>											
5.1.3.1.	Non Stock	Ff 1012 - 13mm	1									
5.1.3.2.	Non Stock	Ff 1013 - 15mm	1									
5.1.3.3.	Non Stock	Ff 1014 - 20mm	1									
5.1.3.4.	Non Stock	Ff 1060 - 25mm	1									
5.1.4.	<b>Elbows Female Combination (P X Fi)</b>											
5.1.4.1.	Non Stock	Ff 2220 - 15mm X 15mm ½" Bsp	1									
5.1.4.2.	Non Stock	Ff 2240 - 20mm X 15mm ½" Bsp	1									
5.1.4.3.	Non Stock	Ff 2250 - 20mm X 20mm ¾" Bsp	1									
5.1.4.4.	Non Stock	Ff 2260 - 25mm X 15mm ½" Bsp	1									
5.1.4.5.	Non Stock	Ff 2270 - 25mm X 20mm ¾" Bsp	1									

SIGNATURE		NAME (PRINT)		DATE	
CAPACITY		NAME OF FIRM			



		Product	Est. Qty.	Does your Offer comply with the specifications		Lead Time	Unit	Manufacturer	Kleinmond Price Per Unit (Incl. VAT)	Hermanus Price Per Unit (Incl. VAT)	Gansbaai Price Per Unit (Incl. VAT)	Indicate Escalation type: ROE (R) Industry (I) CPIX (c)
				Yes	No							
5.2.	<b>End Plugs</b>											
5.2.1.	Non Stock	Ff 1018 - 13mm	1									
5.2.2.	Non Stock	Ff 1019 - 15mm	1									
5.2.3.	Non Stock	Ff 1020 - 20mm	1									
5.2.4.	Non Stock	Ff 1030 - 25mm	1									
5.3.	<b>Male Adaptors (P X Mi)</b>											
5.3.1.	Non Stock	Ff 1021 - 15mm X 15mm ½" Bsp	1									
5.3.2.	Non Stock	Ff 1032 - 15mm X 20mm ¾" Bsp	1									
5.3.3.	Non Stock	Ff 1033 - 20mm X 15mm ½" Bsp	1									
5.3.4.	Non Stock	Ff 1022 - 20mm X 20mm ¾" Bsp	1									
5.3.5.	Non Stock	Ff 1034 - 20mm X 25mm 1" Bsp	1									
5.3.6.	Non Stock	Ff 1036 - 25mm X 15mm ½" Bsp	1									
5.3.7.	Non Stock	Ff 1037 - 25mm X 20mm ¾" Bsp	1									
5.3.8.	Non Stock	Ff 1035 - 25mm X 25mm 1" Bsp	1									
5.4.	<b>Reducers</b>											
5.4.1.	Non Stock	Ff 1004 - 15mm X 13mm	1									
5.4.2.	Non Stock	Ff 1120 - 20mm X 13mm	1									
5.4.3.	Non Stock	Ff 1005 - 20mm X 15mm	1									
5.4.4.	Non Stock	Ff 1110 - 25mm X 15mm	1									
5.4.5.	Non Stock	Ff 1045 - 25mm X 20mm	1									
5.5.	<b>Tees (Equal)</b>											
5.5.1.	Non Stock	Ff 1006 - 13mm	1									
5.5.2.	Non Stock	Ff 1007 - 15mm	1									
5.5.3.	Non Stock	Ff 1008 - 20mm	1									
5.5.4.	Non Stock	Ff 1050 - 25mm	1									

SIGNATURE		NAME (PRINT)		DATE	
CAPACITY		NAME OF FIRM			



		Product	Est. Qty.	Does your Offer comply with the specifications		Lead Time	Unit	Manufacturer	Kleinmond Price Per Unit (Incl. VAT)	Hermanus Price Per Unit (Incl. VAT)	Gansbaai Price Per Unit (Incl. VAT)	Indicate Escalation type: ROE (R) Industry (I) CPIX (c)
				Yes	No							
5.6.	<b>Tees Female Combination (P X Fi)</b>											
5.6.1.	Non Stock	Ff 2130 - 20mm X 15mm 1/2" Bsp	1									
5.6.2.	Non Stock	Ff 2140 - 20mm X 20mm 3/4" Bsp	1									
5.6.3.	Non Stock	Ff 2150 - 25mm X 15mm 1/2" Bsp	1									
5.6.4.	Non Stock	Ff 2160 - 25mm X 20mm 3/4" Bsp	1									
5.7.	<b>Tees Male Combination (P X Mi)</b>											
5.7.1.	Non Stock	Ff 1180 - 13mm X 15mm 1/2" Bsp	1									
5.7.2.	Non Stock	Ff 1009 - 15mm X 15mm 1/2" Bsp	1									
5.7.3.	Non Stock	Ff 1182 - 15mm X 20mm 3/4" Bsp	1									
5.7.4.	Non Stock	Ff 1010 - 20mm X 20mm 3/4" Bsp	1									
5.7.5.	Non Stock	Ff 1011 - 20mm X 15mm 1/2" Bsp	1									
5.7.6.	Non Stock	Ff 1080 - 25mm X 15mm 1/2" Bsp	1									
5.7.7.	Non Stock	Ff 1089 - 25mm X 20mm 3/4" Bsp	1									
5.7.8.	Non Stock	Ff 1300 - 25mm X 25mm 1" Bsp	1									
5.8.	<b>Tees Reducing</b>											
5.8.1.	Non Stock	Ff 1028 - 15mm X 13mm	1									
5.8.2.	Non Stock	Ff 1024 - 20mm X 13mm	1									
5.8.3.	Non Stock	Ff 1025 - 20mm X 15mm	1									
5.8.4.	Non Stock	Ff 1070 - 25mm X 15mm	1									
5.8.5.	Non Stock	Ff 1105 - 25mm X 20mm	1									
5.9.	<b>Snap-On / Full Flow Hose Connectors</b>											
5.9.1.	Non Stock	Sb 350 - 13mm	1									
5.9.2.	Non Stock	Sb 360 - 15mm	1									
5.9.3.	Non Stock	Sb 370 - 20mm	1									

SIGNATURE		NAME (PRINT)		DATE	
CAPACITY			NAME OF FIRM		



		Product	Est. Qty.	Does your Offer comply with the specifications		Lead Time	Unit	Manufacturer	Kleinmond Price Per Unit (Incl. VAT)	Hermanus Price Per Unit (Incl. VAT)	Gansbaai Price Per Unit (Incl. VAT)	Indicate Escalation type: ROE (R) Industry (I) CPIX (c)
				Yes	No							
5.10.	<b>Flow Controls</b>											
5.10.1.	Non Stock	Ff 1140 - 13mm	1									
5.10.2.	Non Stock	Ff 1150 - 15mm	1									
5.10.3.	Non Stock	Ff 1160 - 20mm	1									
5.11.	<b>Reducing Bush</b>											
5.11.1.	Non Stock	Reducing Bush (15mm-20mm) ½" X ¾" Bsp	1									
5.11.2.	Non Stock	Reducing Bush (25mm-15mm) 1" X ½" Bsp	1									
5.11.3.	Non Stock	Reducing Bush (25mm-20mm) 1" X ¾" Bsp	1									
5.11.4.	Non Stock	Reducing Bush (32mm-15mm) 1¼" X ½" Bsp	1									
5.11.5.	Non Stock	Reducing Bush (32mm-20mm) 1¼" X ¾" Bsp	1									
5.11.6.	Non Stock	Reducing Bush (32mm-25mm) 1¼" X 1" Bsp	1									
5.11.7.	Non Stock	Reducing Bush (40mm-15mm) 1½" X ½" Bsp	1									
5.11.8.	Non Stock	Reducing Bush (40mm-20mm) 1½" X ¾" Bsp	1									
5.11.9.	Non Stock	Reducing Bush (40mm-25mm) 1½" X 1" Bsp	1									
5.11.10.	Non Stock	Reducing Bush (40mm-32mm) 1½" X 1¼" Bsp	1									
5.11.11.	Non Stock	Reducing Bush (50mm-20mm) 2" X ¾" Bsp	1									
5.11.12.	Non Stock	Reducing Bush (50mm-20mm) 2" X 1" Bsp	1									
5.11.13.	Non Stock	Reducing Bush (50mm-32mm) 2" X 1¼" Bsp	1									
5.11.14.	Non Stock	Reducing Bush (50mm-40mm) 2" X 1½" Bsp	1									
5.12.	<b>Hex Reducing Nipple</b>											
5.12.1.	Non Stock	(20mm – 15mm) ¾" X ½" Bsp	1									
5.12.2.	Non Stock	(25mm – 15mm) 1" X ½" Bsp	1									
5.12.3.	Non Stock	(25mm – 20mm) 1" X ¾" Bsp	1									

SIGNATURE		NAME (PRINT)		DATE	
CAPACITY			NAME OF FIRM		



		Product	Est. Qty.	Does your Offer comply with the specifications		Lead Time	Unit	Manufacturer	Kleinmond Price Per Unit (Incl. VAT)	Hermanus Price Per Unit (Incl. VAT)	Gansbaai Price Per Unit (Incl. VAT)	Indicate Escalation type: ROE (R) Industry (I) CPIX (c)
				Yes	No							
5.13.	<b>Hex Nipple</b>											
5.13.1.	Non Stock	15mm ½" Bsp	1									
5.13.2.	Non Stock	20mm ¾" Bsp	1									
5.13.3.	Non Stock	25mm 1" Bsp	1									
5.13.4.	Non Stock	32mm 1¼" Bsp	1									
5.13.5.	Non Stock	40mm 1½" Bsp	1									
5.13.6.	Non Stock	50mm 2" Bsp	1									
5.14.	<b>Emjay Socket</b>											
5.14.1.	Non Stock	15mm ½" Bsp (15mm)	1									
5.14.2.	Non Stock	20mm ¾" Bsp (20mm)	1									
5.14.3.	Non Stock	25mm 1" Bsp (25mm)	1									
5.15.	<b>Connector</b>											
5.15.1.	Non Stock	15mm	1									
5.15.2.	Non Stock	20mm	1									
5.15.3.	Non Stock	25mm	1									
5.15.4.	Non Stock	32mm	1									
5.15.5.	Non Stock	40mm	1									
5.15.6.	Non Stock	50mm	1									
5.16.	<b>Equal Tee-piece</b>											
5.16.1.	Non Stock	15mm	1									
5.16.2.	Non Stock	20mm	1									
5.16.3.	Non Stock	25mm	1									
5.16.4.	Non Stock	32mm	1									
5.16.5.	Non Stock	40mm	1									

SIGNATURE		NAME (PRINT)		DATE	
CAPACITY			NAME OF FIRM		



		Product	Est. Qty.	Does your Offer comply with the specifications		Lead Time	Unit	Manufacturer	Kleinmond Price Per Unit (Incl. VAT)	Hermanus Price Per Unit (Incl. VAT)	Gansbaai Price Per Unit (Incl. VAT)	Indicate Escalation type: ROE (R) Industry (I) CPIX (c)
				Yes	No							
5.16.6.	Non Stock	50mm	1									
5.17.	<b>Elbow</b>											
5.17.1.	Non Stock	15mm	1									
5.17.2.	Non Stock	20mm	1									
5.17.3.	Non Stock	25mm	1									
5.17.4.	Non Stock	32mm	1									
5.17.5.	Non Stock	40mm	1									
5.17.6.	Non Stock	50mm	1									
5.18.	<b>Male Combination Tee-Piece (Pop-Up Tee Piece)</b>											
5.18.1.	Non Stock	15mm X 15mm ½" BSP	1									
5.18.2.	Non Stock	20mm X 15mm ½" BSP	1									
5.18.3.	Non Stock	20mm X 20mm ¾" BSP	1									
5.18.4.	Non Stock	25mm X 15mm ½" BSP	1									
5.18.5.	Non Stock	25mm X 20mm ¾" BSP	1									
5.18.6.	Non Stock	25mm X 25mm 1" BSP	1									
5.18.7.	Non Stock	32mm X 15mm ½" BSP	1									
5.18.8.	Non Stock	32mm X 20mm ¾" BSP	1									
5.18.9.	Non Stock	32mm X 25mm 1" BSP	1									
5.18.10.	Non Stock	32mm X 32mm 1¼" BSP	1									
5.19.	<b>Male Combination Elbow (Pop-Up Elbow)</b>											
5.19.1.	Non Stock	15mm X 15mm ½" BSP	1									
5.19.2.	Non Stock	20mm X 15mm ½" BSP	1									
5.19.3.	Non Stock	20mm X 20mm ¾" BSP	1									
5.19.4.	Non Stock	25mm X 15mm ½" BSP	1									
5.19.5.	Non Stock	25mm X 20mm ¾" BSP	1									

SIGNATURE		NAME (PRINT)		DATE	
CAPACITY		NAME OF FIRM			



		Product	Est. Qty.	Does your Offer comply with the specifications		Lead Time	Unit	Manufacturer	Kleinmond Price Per Unit (Incl. VAT)	Hermanus Price Per Unit (Incl. VAT)	Gansbaai Price Per Unit (Incl. VAT)	Indicate Escalation type: ROE (R) Industry (I) CPIX (c)
				Yes	No							
5.19.6.	Non Stock	25mm X 25mm 1" BSP	1									
5.19.7.	Non Stock	32mm X 32mm 1¼" BSP	1									
5.20.	<b>Female Combination Elbow</b>											
5.20.1.	Non Stock	15mm X 15MM ½" BSP	1									
5.20.2.	Non Stock	20mm X 15MM ½" BSP	1									
5.20.3.	Non Stock	20mm X 20MM ¾" BSP	1									
5.20.4.	Non Stock	25mm X 15MM ½" BSP	1									
5.20.5.	Non Stock	25mm X 20MM ¾" BSP	1									
5.20.6.	Non Stock	25mm X 25MM 1" BSP	1									
5.20.7.	Non Stock	40mm X 40MM 1½" BSP	1									
5.20.8.	Non Stock	50mm X 50MM 2" BSP	1									
5.21.	<b>Male Adaptor (P X MI)</b>											
5.21.1.	Non Stock	15mm X ½" BSP	1									
5.21.2.	Non Stock	15mm X ¾" BSP	1									
5.21.3.	Non Stock	20mm X ¾" BSP	1									
5.21.4.	Non Stock	20mm X 1" BSP	1									
5.21.5.	Non Stock	25mm X 1" BSP	1									
5.21.6.	Non Stock	25mm X 1¼" BSP	1									
5.21.7.	Non Stock	32mm X 1¼" BSP	1									
5.22.	<b>Manifolds</b>											
5.22.1.	Non Stock	Manifold 2 Outlet	1									
5.22.2.	Non Stock	Manifold 3 Outlet	1									
5.22.3.	Non Stock	Manifold 4 Outlet	1									
5.23.	<b>PVC Green Flexible Tubing</b>											
5.23.1.	Non Stock	4mm X 100m – Green	1									

SIGNATURE		NAME (PRINT)		DATE	
CAPACITY		NAME OF FIRM			



		Product	Est. Qty.	Does your Offer comply with the specifications		Lead Time	Unit	Manufacturer	Kleinmond Price Per Unit (Incl. VAT)	Hermanus Price Per Unit (Incl. VAT)	Gansbaai Price Per Unit (Incl. VAT)	Indicate Escalation type: ROE (R) Industry (I) CPIX (c)
				Yes	No							
5.23.2.	Non Stock	4mm X 600mm - Green	1									
5.24.	<b>Pipe Ply Non SABS Class 3</b>											
5.24.1.	Non Stock	15mm Class 3	1									
5.24.2.	Non Stock	20mm Class 3	1									
5.24.3.	Non Stock	25mm Class 3	1									
5.24.4.	Non Stock	32mm Class 3	1									
5.24.5.	Non Stock	40mm Class 3	1									
5.24.6.	Non Stock	50mm Class 3	1									
5.25.	<b>Pipe Poly Non Sabs Class 6</b>											
5.25.1.	Non Stock	15mm Class 6	1									
5.25.2.	Non Stock	20mm Class 6	1									
5.25.3.	Non Stock	25mm Class 6	1									
5.25.4.	Non Stock	32mm Class 6	1									
5.25.5.	Non Stock	40mm Class 6	1									
5.25.6.	Non Stock	50mm Class 6	1									
5.26.	<b>Standpipe</b>											
5.26.1.	Non Stock	15mm X 300mm	1									
5.26.2.	Non Stock	15mm X 400mm	1									
5.26.3.	Non Stock	15mm X 500mm	1									
5.26.4.	Non Stock	15mm X 600mm	1									
5.26.5.	Non Stock	15mm X 750mm	1									
5.26.6.	Non Stock	15mm X 1000mm	1									
5.26.7.	Non Stock	15mm X 1200mm	1									
5.26.8.	Non Stock	15mm X 1500mm	1									

SIGNATURE		NAME (PRINT)		DATE	
CAPACITY		NAME OF FIRM			



		Product	Est. Qty.	Does your Offer comply with the specifications		Lead Time	Unit	Manufacturer	Kleinmond Price Per Unit (Incl. VAT)	Hermanus Price Per Unit (Incl. VAT)	Gansbaai Price Per Unit (Incl. VAT)	Indicate Escalation type: ROE (R) Industry (I) CPIX (c)
				Yes	No							
5.27.	<b>Sprinklers &amp; Nozzles</b>											
5.27.1.	Non Stock	Sprinklers: 4" Slim Spray Head W/ 12' Adjustable Arc Nozzle Saturn Iii Pop-Up Gear Driven Sprinkler Head	1									
5.27.2.		(Orbit 5300 Series Or Similar Approved)	1									
5.27.3.	Non Stock	Sprinklers: Voyager Ii Professional Pop-Up Gear Driven Sprinkler Head Or Similar Approved	1									
5.27.4.	Non Stock	Sprinklers: Rotor Pop-Up Sprinklers (Rainbird Falcon 6504 Rotor Or Compatible)	1									
5.27.5.	Non Stock	Sprinklers: Hunter Pgp Ultra Rotor Sprinkler Heads (Or Compatible)	1									
5.27.6.	Non Stock	Sprinklers: 1/2 In. Or 3/4 In. Satellite Ii Pop-Up Impact Sprinkler (Orbit Or Similar Approved)	1									
5.27.7.	Non Stock	Sprinklers: Sime Pop-Up Sports Gun (Psg)	1									
5.27.8.	Non Stock	Nozzle Micro Rainjet Head Black Rotator 360d Micro Head Complete With Spreader And Nozzle.	1									
5.27.9.	Non Stock	Stake Assembly – Complete (Assembled With: 450mm Stake, 600mm Tube, Barbed Adaptor, Jet)	1									
5.27.10.	Non Stock	Barbed (Disc): 4mm X 4mm	1									
5.27.11.	Non Stock	Threaded/Barbed: 4mm X 2ba	1									
5.27.12.	Non Stock	Nozzle Pro 15a Spray Nozzles	1									
5.27.13.	Non Stock	Valve Solenoid Orbit Jar Top	1									
5.27.14.	Non Stock	Automatic Inline Jar-Top Valve Without Flow Control. Both Ends 1" Bsp- Threaded	1									
5.27.15.	Non Stock	Valve Solenoid Coil Only Orbit Or Compatible	1									
5.27.16.	Non Stock	Transformer Interchangeable With Most Brands Of 24v Timers	1									
5.27.17.	Non Stock	Valve Box: 250mm Round No Lock Blue / Green	1									

SIGNATURE		NAME (PRINT)		DATE	
CAPACITY			NAME OF FIRM		

MUNISIPALITEIT



MUNICIPALITY

		Product	Est. Qty.	Does your Offer comply with the specifications		Lead Time	Unit	Manufacturer	Kleinmond Price Per Unit (Incl. VAT)	Hermanus Price Per Unit (Incl. VAT)	Gansbaai Price Per Unit (Incl. VAT)	Indicate Escalation type: ROE (R) Industry (I) CPIX (c)
				Yes	No							
5.27.18.	Non Stock	Valve Box Rectangular – Economy 460mm X 330mm Rectangular Valve Box With Lid	1									
5.27.19.	Non Stock	Valve Box Rectangular Irrigation - 380mm X 240mm Rectangular Valve Box With Lid	1									
5.28.	<b>Controllers</b>											
5.28.1.	Non Stock	Controllers: Irritrol Junior Dc (Or Compatible)	1									
5.28.2.	Non Stock	Controller Orbit Indoor (Or Compatible) 4 Station	1									
5.28.3.	Non Stock	Controller Orbit Indoor (Or Compatible) 6 Station	1									

SIGNATURE		NAME (PRINT)		DATE	
CAPACITY			NAME OF FIRM		



**19. MBD 7.1. – CONTRACT FORM - PURCHASE OF GOODS**

- NB:**
1. This form must be completed in duplicate by both the successful bidder (Part 1) and the purchaser (Part 2). The form must be signed in the original so that the successful bidder and the purchaser will be in possession of a signed contracts for their respective records.
  2. NO correction fluid/tape may be used.
    - a. In the event of a mistake having been made, it shall be crossed out in ink and be accompanied by an initial at each and every alteration.

**PART 1 (To be completed by the BIDDER)**

1. I hereby undertake to supply all or any of the goods and/or works described in the attached bidding documents to **OVERSTRAND MUNICIPALITY** in accordance with the requirements and specifications stipulated in bid number **SC1758/2017: SUPPLY AND DELIVERY OF PLUMBING MATERIAL, PLUMBING TOOLS AND IRRIGATION ITEMS FOR A CONTRACT PERIOD ENDING 30 JUNE 2020**, at the price(s) as per pricing schedule.
2. My offer(s) remain(s) binding upon me and open for acceptance by the purchaser during the validity period indicated and calculated from the closing time of bid.
3. The following documents shall be deemed to form and be read and construed as part of this agreement:
  - (i) Bidding documents, viz
    1. Invitation to bid
    2. Tax clearance certificate
    3. Pricing schedule(s)
    4. Technical Specification(s)
    5. Preference claims in terms of the Preferential Procurement Regulations 2011
    6. Declaration of interest
    7. Special Conditions of Contract;
    8. General Conditions of Contract; and
    9. Declaration in terms of local content
4. I confirm that I have satisfied myself as to the correctness and validity of my bid; that the price(s) and rate(s) quoted cover all the goods and/or works specified in the bidding documents; that the price(s) and rate(s) cover all my obligations and I accept that any mistakes regarding price(s) and rate(s) and calculations will be at my own risk.
5. I accept full responsibility for the proper execution and fulfilment of all obligations and conditions devolving on me under this agreement as the principal liable for the due fulfilment of this contract.
6. I declare that I have no participation in any collusive practices with any bidder or any other person regarding this or any other bid.
7. I confirm that I am duly authorised to sign this contract.

SIGNATURE		NAME (PRINT)	
CAPACITY		DATE	
NAME OF FIRM			
WITNESS 1:		WITNESS 2:	
DATE:			



**CONTRACT FORM - PURCHASE OF GOODS/WORKS**

**PART 2 (To be completed by OVERSTRAND MUNICIPALITY)**

1. I, \_\_\_\_\_,  
 in my capacity as \_\_\_\_\_,  
 accept your bid under reference number \_\_\_\_\_,  
 dated \_\_\_\_\_,  
 for the supply of goods/works indicated hereunder and/or further specified in the annexure(s).
  
2. An official order indicating delivery instructions is forthcoming.
  
3. I undertake to make payment for the goods/works delivered in accordance with the terms and conditions of the contract, within 30 (thirty) days after receipt of an invoice accompanied by the delivery note.
  
4. I confirm that I am duly authorized to sign this contract.

SIGNED AT \_\_\_\_\_ on this \_\_\_\_\_ day of \_\_\_\_\_ 20\_\_\_\_.

TO BE COMPLETED BY THE OVERSTRAND MUNICIPALITY		
SIGNATURE:		<b>OFFICIAL STAMP:</b>
NAME (PRINT):		
WITNESS 1:		
WITNESS 2:		

**20. DECLARATION BY TENDERER**

I / We acknowledge that I / we am / are fully acquainted with the contents of the conditions of tender of this tender document and that I / we accept the conditions in all respects.

I / We agree that the laws of the Republic of South Africa shall be applicable to the contract resulting from the acceptance of \*my / our tender and that I / we elect *domicillium citandi et executandi* (physical address at which legal proceedings may be instituted) in the Republic at:

\_\_\_\_\_

\_\_\_\_\_

\_\_\_\_\_

I / We accept full responsibility for the proper execution and fulfillment of all obligations and conditions devolving in me / us under this agreement as the principal liable for the due fulfillment of this contract.

I / We furthermore confirm I / we satisfied myself / ourselves as to the corrections and validity of my / our tender; that the price quoted cover all the work / items specified in the tender documents and that the price(s) cover all my / our obligations under a resulting contract and that I / we accept that any mistake(s) regarding price and calculations will be at my / our risk.

I / We furthermore confirm that my / our offer remains binding upon me / us and open for acceptance by the Purchases / Employer during the validity period indicated and calculated from the closing date of the bid.

SIGNATURE		NAME (PRINT)	
CAPACITY		DATE	
NAME OF FIRM			
WITNESS 1		WITNESS 2	



## PART C – DATABASE REGISTRATION

<b>A</b>	<b>If you are a bidder, DULY REGISTERED as a Preferred Supplier on the Supply Chain Management Database of the Overstrand Municipality, COMPLETE THIS SECTION</b>		
<b>SCM DATABASE REGISTRATION NUMBER</b>		<b>SC</b>	
<b>NAME OF FIRM</b>			
<b>SIGNATURE</b>		<b>CAPACITY</b>	
<b>NAME (PRINT)</b>			

<b>B</b>	<b>If you are a bidder, NOT DULY REGISTERED as a Preferred Supplier on the Supply Chain Management Database of the Overstrand Municipality, it is compulsory to complete and attach the following forms:</b>		
1	Database Registration Form		
2	Questionnaire For Preferential Procurement Policy		
3	Declaration By Supplier		
4	National Small Business Act No. 102 Of 1996 Classification		
5	Documents Required		
6	Nature Of Operations, Products Or Services		
7	Credit Order Instruction		



**FOR OFFICE USE ONLY**

<b>FORMS REMOVED &amp; HANDED TO DATABASE OFFICIAL</b>					
<b>1</b>	<b>Database Registration Form</b>	Yes		No	
<b>2</b>	<b>Questionnaire For Preferential Procurement Policy</b>	Yes		No	
2.1	BBBEE Certificate / Letter from Auditor				
<b>3</b>	<b>Declaration By Supplier</b>	Yes		No	
<b>4</b>	<b>National Small Business Act No. 102 Of 1996 Classification</b>	Yes		No	
<b>5</b>	<b>Nature Of Operations, Products Or Services</b>	Yes		No	
<b>6</b>	<b>Credit Order Instruction</b>	Yes		No	
<b>7</b>	<b>Documents Required:</b>				
7.1	Copy of Company Registration Documentation	Yes		No	
7.2	Tax Clearance Certificate	Yes		No	
7.3	PAYE	Yes		No	
7.4	UIF Certificate / proof	Yes		No	
7.5	WCA Certificate / Letter of Good Standing	Yes		No	
7.6	Copies of ID documents of Directors / Members / Shareholders / Partners.	Yes		No	
<b>8.</b>	<b>LIST ANY OTHER FORMS REMOVED AND SUBMITTED TO DATABASE OFFICIAL:</b>				
<i>I confirm that I have removed the forms as indicated above from the tender document and forwarded it to the Supplier Database Official</i>					
	<b>Removed</b>	<b>Checked</b>			
<b>Print Name</b>					
<b>Signature</b>					
<b>Date</b>					







**PREFERENTIAL PROCUREMENT REGULATIONS 2011**

**(a) POINTS AWARDED FOR B-BBEE STATUS LEVEL OF CONTRIBUTION**

i. In terms of Regulation 5 (2) and 6 (2) of the Preferential Procurement Regulations, preference points must be awarded to a bidder for attaining the B-BBEE status level of contribution in accordance with the table below:

B-BBEE Status Level of Contributor	Number of points (90/10 system)	Number of points (80/20 system)
1	10	20
2	9	18
3	8	16
4	5	12
5	4	8
6	3	6
7	2	4
8	1	2
Non-compliant contributor	0	0

- ii. Bidders who qualify as EMEs in terms of the B-BBEE Act must submit a certificate issued by an Accounting Officer as contemplated in the CCA or a Verification Agency accredited by SANAS or a Registered Auditor. Registered auditors do not need to meet the prerequisite for IRBA's approval for the purpose of conducting verification and issuing EMEs with B-BBEE Status Level Certificates.
- iii. Bidders other than EMEs must submit their original and valid B-BBEE status level verification certificate or a certified copy thereof, substantiating their B-BBEE rating issued by a Registered Auditor approved by IRBA or a Verification Agency accredited by SANAS.
- iv. A trust, consortium or joint venture, will qualify for points for their B-BBEE status level as a legal entity, provided that the entity submits their B-BBEE status level certificate.
- v. A trust, consortium or joint venture will qualify for points for their B-BBEE status level as an unincorporated entity, provided that the entity submits their consolidated B-BBEE scorecard as if they were a group structure and that such a consolidated B-BBEE scorecard is prepared for every separate bid.
- vi. Tertiary institutions and public entities will be required to submit their B-BBEE status level certificates in terms of the specialized scorecard contained in the B-BBEE Codes of Good Practice.
- vii. A person will not be awarded points for B-BBEE status level if it is indicated in the bid documents that such a bidder intends sub-contracting more than 25% of the value of the contract to any other enterprise that does not qualify for at least the points that such a bidder qualifies for, unless the intended sub-contractor is an EME that has the capability and ability to execute the sub-contract.
- viii. A person awarded a contract may not sub-contract more than 25% of the value of the contract to any other enterprise that does not have an equal or higher B-BBEE status level than the person concerned, unless the contract is sub-contracted to an EME that has the capability and ability to execute the sub-contract.

**(b) BID DECLARATION**

i. Bidders who claim points in respect of B-BBEE Status Level of Contribution must complete the following:

i. B-BBEE STATUS LEVEL OF CONTRIBUTION CLAIMED IN TERMS OF PARAGRAPHS 1.3.1.2 AND 5.1	
1.	B-BBEE Status Level of Contribution as reflected on the B-BBEE Certificate
2.	Points claimed in respect of Level of Contribution (maximum of 10 or 20 points)

*(Points claimed in respect of paragraph 6.1 must be in accordance with the table reflected in paragraph 5.1 and must be substantiated by means of a B-BBEE certificate issued by a Verification Agency accredited by SANAS or a Registered Auditor approved by IRBA or an Accounting Officer as contemplated in the CCA).*

3	Persentasie aandeelhouing van persone geklassifiseer as <b>jeug</b> . (18 – 35 Jaar oud) / Percentage of shareholding of persons in the business classified as <b>youth</b> . (18 – 35 Years old) / Ipersenti labantu abanezabelo kwinkonzo zoshishino ababizwa ngokuba <b>lulutsha</b> (18 – 35 Yeminyaka)	%
4	Is u besigheid geleë binne die jurisdiksie van die munisipaliteit ?	In/Ngaphakathi
	Is your business established within the area of jurisdiction of the Municipality? Ingaba ishishini lakho limi kwingingqi elawulwa nguMasipala wesithili?	Uit/Out/Ngaphandle

Hiermee sertifiseer ek/ons die ondergetekende en die getuienisse dat bogenoemde inligting korrek is. / I/We hereby certify that the abovementioned information is correct signed by myself/ourselves and the witnesses. / Mna/Thina siqinisekisa ukuba ezi nkukacha zingasentla zilungile kwaye zisayinwe ndim/sithi kunye namangqina

<b>Handtekening / Signature / Osayinileyo</b>	<b>Getuie / As Witness / Njengengqina</b>



**DECLARATION BY SUPPLIER**

1. This document serves as a declaration to be used by the municipality in ensuring that when goods and services are being procured, all reasonable steps are taken to combat the abuse of the supply chain management system. No Registration will be accepted from persons in the service of the state\*.

2.(a) Any prospective supplier, having a kinship with persons in the service of the state, including a blood relationship, may in terms of current legislation register on the Municipality's Database. In view of possible allegations of favouritism, should a resulting bid, or part thereof, be awarded to suppliers connected with or related to persons in the service of the state, it is required that the supplier or his/her authorised representative declare their position in relation to the evaluating/adjudicating authority and/or take an oath declaring his/her interest.

2.(b) The request for registration on the Municipality's database may be rejected if the supplier, or any of its directors/members/partners have:

- (i) abused the municipality's supply chain management system or committed any improper conduct in relation to such system;
- (ii) been convicted for fraud or corruption during the past five years;
- (iii) willfully neglected, reneged on or failed to comply with any government, municipal or other public sector contract during the past five years;
- (iv) being a person whose tax matters are not cleared by the South African Revenue Services; or
- (v) been listed in the Register for Tender Defaulters in terms of section 29 of the Prevention and Combating of Corrupt Activities Act (No 12 of 2004).

3.	In order to give effect to the above, the following questionnaire must be completed and signed before a Commissioner of Oaths.			
3.1	Print full Name:			
3.2	Company/CC Registration or ID Number:			
3.3	Are you presently <i>in the service of the state</i> ? *	YES	NO	
3.3.1	<b>If so, furnish particulars.</b>			
3.4	Have you been <i>in the service of the state</i> for the past twelve months?	YES	NO	
3.4.1	<b>If so, furnish particulars.</b>			
3.5	Do you, have any relationship (family, friend, other) with persons <i>in the service of the state</i> and who may be involved with the evaluation and or adjudication of any prospective bid?	YES	NO	
3.5.1	<b>If so, furnish particulars.</b>			
3.6	Are you, aware of any relationship (family, friend, other) between a supplier and any persons <i>in the service of the state</i> who may be involved with the evaluation and or adjudication of any bid?	YES	NO	
3.6.1	<b>If so, furnish particulars.</b>			
3.7	Are any of your company's directors, managers, principle shareholders or stakeholders <i>in the service of the state</i> ?	YES	NO	
3.7.1	<b>If so, furnish particulars.</b>			
3.8	Is any spouse, child or parent of your company's directors, managers, principle shareholders or stakeholders <i>in the service of the state</i> ?	YES	NO	
3.8.1	<b>If so, furnish particulars.</b>			
3.9	Is the supplier or any of its directors/partners listed on the National Treasury's database as a company or person prohibited from doing business with the public sector?	YES	NO	
3.9.1	<b>If so, furnish particulars.</b>			



3.10	Is the supplier or any of its directors listed on the Register for Tender Defaulters in terms of section 29 of the Prevention and Combating of Corrupt Activities Act (No 12 of 2004)?	YES		NO	
3.10.1	If so, furnish particulars.				
3.11	Was the supplier or any of its directors convicted by a court of law (including a court of law outside the Republic of South Africa) for fraud or corruption during the past five years?	YES		NO	
3.11.1	If so, furnish particulars.				
3.12	Does the supplier or any of its directors owe any municipal rates and taxes or municipal charges to the municipality / municipal entity, or to any other municipality / municipal entity, that is in arrears for more than three months?	YES		NO	
3.12.1	If so, furnish particulars.				
3.13	Was any contract between the supplier and the municipality / municipal entity or any other organ of state terminated during the past five years on account of failure to perform on or comply with the contract?	YES		NO	
3.13.1	If so, furnish particulars.				

**CERTIFICATION**

I, THE UNDERSIGNED, \_\_\_\_\_, CERTIFY THAT THE INFORMATION FURNISHED ON THIS DECLARATION FORM IS CORRECT. I ACCEPT THAT THE STATE MAY ACT AGAINST ME SHOULD THIS DECLARATION PROVE TO BE FALSE.

<b>Signature</b>	<b>Position</b>	<b>Date</b>

\* MSCM Regulations: "in the service of the state" means to be –

- 6. a member of –
  - 6.1. any municipal council;
  - 6.2. any provincial legislature; or
  - 6.3. the national Assembly or the national Council of provinces;
- 7. a member of the board of directors of any municipal entity;
- 8. an official of any municipality or municipal entity;
- 9. an employee of any national or provincial department, national or provincial public entity or constitutional institution within the meaning of the Public Finance Management Act, 1999 (Act No.1 of 1999);
- 10. a member of the accounting authority of any national or provincial public entity; or
- 11. an employee of Parliament or a provincial legislature.

<p style="text-align: center;"><b>COMMISSIONER OF OATHS</b></p> <p>Signed and sworn to before me at _____, on this _____ day of _____ 20____,</p> <p>by the Deponent, who has acknowledged that he/she knows and understands the contents of this Affidavit, it is true and correct to the best of his/her knowledge and that he/she has no objection to taking the prescribed oath, and that the prescribed oath will be binding on his/her conscience.</p> <p><b>COMMISSIONER OF OATHS:-</b></p> <p>Position: _____</p> <p>Address: _____</p> <p>Tel: _____</p>	<p><b>Apply official stamp of authority on this page:</b></p>
---	---

**ETHICS COMMITMENT FOR SUPPLIERS OF THE OVERSTRAND LOCAL MUNICIPALITY**

**In our dealings with the Overstrand Local Municipality we commit to uphold high standards of ethics. Among other things this means:**

- We will be honest and deal in good faith;
- We will not improperly try to influence any municipal official or decision; We will avoid all conflicts of interest;
- We will not engage in any form of corruption (e.g. paying bribes, giving kickbacks); We will not give gifts to municipal officials or councillors;
- We will not be involved in collusion with other service providers (i.e. price-fixing);
- We will ensure that all information we submit to the municipality is accurate and truthful (e.g. we will not engage in B-BBEE fronting).
- We will ensure and take accountability to keep our database records up to date, avoiding misrepresentation.
- We will ensure to comply with legislative requirements applicable.
- We will inform the Overstrand of any unethical behaviour known, either from other suppliers or Overstrand officials, supported by the protection of our Whistle Blowing policy.
- We will contribute by all means necessary, in building a positive ethical culture in the Overstrand.

**This is our commitment to help build an ethical Overstrand.**

<b>Name of Company:</b>	
<b>Name of authorised person:</b>	
<b>Signature:</b>	
<b>Date:</b>	

## National Small Business Act No. 102 of 1996 Classification

1. Indicate your Economic Sector - Give full description in 1.4 on page 1		2. Indicate the size of your Business if the National Small Business Act applies to your enterprise.				
Sector or sub-sectors in accordance with the Standard Industrial Classification		Size of class	Total full-time equivalent of paid employees Less than:	Total annual turnover Less than:	Total gross asset value (fixed property excluded) Less than:	Indicate the category of your business "X"
Please indicate your Sector	"X"	Not applicable	Not applicable	Not applicable	Not applicable	Not applicable
All Tiers of Government 00001 - 09999		Medium	100	R 5 m	R 5 m	
Agriculture		Small	50	R 3 m	R 3 m	
11001 - 14999		Very small	10	R 0.50 m	R 0.50 m	
Mining and Quarrying		Micro	5	R 0.20 m	R 0.10 m	
21001 - 29999		Medium	200	R 39 m	R 23 m	
Manufacturing		Small	50	R 10 m	R 6 m	
30001 - 39999		Very small	20	R 4 m	R 2 m	
Electricity, Gas and Water		Micro	5	R 0.20 m	R 0.10 m	
41001 - 42999		Medium	200	R 51 m	R 19 m	
Construction		Small	50	R 13 m	R 5 m	
50001 - 50999		Very small	20	R 5 m	R 2 m	
Wholesale Trade, Commercial Agents and Allied Services		Micro	5	R 0.20 m	R 0.10 m	
58001 - 61999		Medium	200	R 51 m	R 19 m	
Retail and Motor Trade and Repair Services		Small	50	R 13 m	R 5 m	
62101 - 63500		Very small	20	R 5.10 m	R 1.90 m	
Catering, Accommodation and other Trade		Micro	5	R 0.20 m	R 0.10 m	
64101 - 64299		Medium	200	R 26 m	R 5 m	
Transport, Storage and Communications		Small	50	R 6 m	R 1 m	
71001 - 75999		Very small	20	R 3 m	R 0.50 m	
Finance and Business Services		Micro	5	R 0.20 m	R 0.10 m	
81001 - 88999		Medium	200	R 64 m	R 10 m	
Community, Social and Personal Services		Small	50	R 32 m	R 5 m	
91001 - 99999		Very small	20	R 6 m	R 0.60 m	
		Micro	5	R 0.20 m	R 0.10 m	
		Medium	200	R 39 m	R 6 m	
		Small	50	R 19 m	R 3 m	
		Very small	20	R 4 m	R 0.60 m	
		Micro	5	R 0.20 m	R 0.10 m	
		Medium	200	R 13 m	R 3 m	
		Small	50	R 6 m	R 1 m	
		Very small	20	R 1.50 m	R 0.90 m	
		Micro	5	R 0.20 m	R 0.10 m	
		Medium	200	R 26 m	R 6 m	
		Small	50	R 13 m	R 3 m	
		Very small	20	R 3 m	R 0.60 m	
		Micro	5	R 0.20 m	R 0.10 m	
		Medium	200	R 26 m	R 5 m	
		Small	50	R 13 m	R 3 m	
		Very small	20	R 3 m	R 0.50 m	
		Micro	5	R 0.20 m	R 0.10 m	
		Medium	200	R 13 m	R 6 m	
		Small	50	R 6 m	R 3 m	
		Very small	20	R 1 m	R 0.60 m	
		Micro	5	R 0.20 m	R 0.10 m	





**DOCUMENTS REQUIRED**

DOCUMENTS REQUIRED	SOLE PROPRIETOR	CC'S AND PRIVATE COMPANIES	PARTNER-SHIPS	PUBLIC COMPANY	BUSINESS TRUST	NON PROFIT ORGANIZATIONS (NPO)	WHERE TO GET DOCUMENTS
<b>COMPANY REGISTRATION CERTIFIED COPIES</b>	N/A	Certificate of incorporation CK1/CK2	Partnership agreement	Certificate of Incorporation CM3	Trust agreement	Certificate of Incorporation Section 21	Registrar of CC's & Companies
<b>PROOF OF OWNERSHIP CERTIFIED COPIES</b>	N/A	Shareholding CK1/CK2	Partnership agreement	Shareholding CM3	Trustees details: Letter of Authority	Auditor's letter no shareholding	Registrar of CC's & Companies
<b>PROOF OF BANKING</b>	Bank statement/ cancelled cheque	Bank statement/ cancelled cheque	Bank statement/ cancelled cheque	Bank statement/ cancelled cheque	Bank statement/ cancelled cheque	Bank statement/ cancelled cheque	Branch of bank at which Account is.
<b>TAX CLEARANCE CERTIFICATE</b>	For the Owner or the business	For the company / cc	For each individual shareholder	For the company	For the trust	For the NPO	SARS
<b>P.A.Y.E</b>	If staff are employed	If staff are employed	If staff are employed	If staff are employed	If staff are employed	If staff are employed	SARS
<b>VAT REGISTRATION</b>	Yes	Yes	Yes	Yes	Yes	Yes	SARS
<b>U.I.F Certificate</b>	YES	YES, if staff remuneration	YES, if staff remuneration	YES, if staff remuneration	YES, if staff remuneration	YES, if staff remuneration	Department of Labour
<b>Workman's Compensation</b>	YES, if staff remuneration	YES, if staff remuneration	YES, if staff remuneration	YES, if staff remuneration	YES, if staff remuneration	YES, if staff remuneration	Department of Labour
<b>Security Officer's Board</b>	If applicable –for security industry	If applicable –for security industry	If applicable –for security industry	If applicable –for security industry	If applicable –for security industry	If applicable –for security industry	Security Service Regulatory Authority
<b>Proof of Disability</b>	If owner is disabled	If Shareholder is disable	If Shareholder is disabled	If Shareholder is disable	If Shareholder is disable	If Shareholder is disabled	
<b>Proof of Identity CERTIFIED</b>	Owner	Directors / Members	Partners	Directors	Trustees	Directors	

<b>FOR OFFICE USE ONLY:</b>			
<b>BUSINESS NAME</b>			
<b>DATE RECEIVED</b>		<b>DATE CAPTURED</b>	
<b>ACCEPTED</b>			
<b>DATABASE REGISTRATION NUMBER</b>			