

**REMAINDER ERF 243, MEERENBOSCH: APPLICATION FOR AMENDMENT OF ARCHITECTURAL GUIDELINES: F BOTHA (obo MEERENBOSCH HOMEOWNERS ASSOCIATION)**

Notice is hereby given in terms of Section 48 of the Overstrand Municipality Amendment By-Law on Municipal Land Use Planning, 2020 that an application has been received for amendment of the standard house plan and regulations of Meerenbosch in terms of Section 16(2)(l) to accommodate the development proposal on the property concerned.

Full details regarding the proposal are available for inspection during weekdays between 08:00 and 16:30 at the Department: Town Planning, Paterson Street, Hermanus. Any written comments may be submitted in accordance with the provisions of Sections 51 and 52 of the said By-Law to the Municipality (16 Paterson Street, Hermanus / (f) 0283132093 / [loretta@overstrand.gov.za](mailto:loretta@overstrand.gov.za)) on or before **18 June 2021**, quoting your name, address and contact details, interest in the application and reasons for comments. Telephonic enquiries can be made to the Town Planner, **Mr. H Olivier** at 028-313 8900. The Municipality may refuse to accept comments received after the closing date. Any person who cannot read or write may visit the Town Planning Department where a municipal official will assist them in order to formalize their comment.

**RESTANT ERF 243, MEERENBOSCH: AANSOEK OM WYSIGING VAN ARGITEKTONIESE RIGLYNE: F BOTHA (nms MEERENBOSCH HOMEOWNERS ASSOCIATION)**

Kennis word hiermee gegee ingevolge Artikel 48 van die Overstrand Munisipaliteit Gewysigde Verordening vir Munisipale Grondgebruikbeplanning, 2020 dat 'n aansoek om wysiging van die standaard bouplan en regulasies van Meerenbosch ontvang is ingevolge Artikel 16(2)(l) om die voorgestelde ontwikkeling op die eiendom te akkommodeer.

Volle besonderhede rakende die voorstel is beskikbaar vir inspeksie gedurende weksdae tussen 08:00 en 16:30 by die Departement: Stadsbeplanning, Patersonstraat 16, Hermanus. Enige kommentaar op die voorstel moet skriftelik ingedien word in terme van Artikels 51 en 52 van die voorgeskrewe Verordening na die Munisipaliteit (Patersonstraat 16, Hermanus / (f) 0283132093 / [loretta@overstrand.gov.za](mailto:loretta@overstrand.gov.za)) voor of op **18 Junie 2021**, met die naam, adres en kontakbesonderhede, belang in die aansoek sowel as redes vir die kommentaar aangedui. Telefoniese navrae kan gerig word aan die Stadsbeplanner, **Mnr. H Olivier** by 028-313 8900. Die Munisipaliteit mag weier om die kommentaar te aanvaar na die sluitingsdatum. Enige persoon wat nie kan lees of skryf nie kan die Departement Stadsbeplanning besoek waar hul deur 'n munisipale amptenaar bygestaan sal word ten einde hul kommentaar te formaliseer.

**INTSALELA YESIZA 243, EMEERENBOSCH: ISICELO SOKULUNGISWA KWEZIKHOKHELO ZOYILO LWEZKHIWO: F BOTHA (obo MEERENBOSCH HOMEOWNERS ASSOCIATION)**

Isaziso sinikwe ngokwemiqathango yeCandelo 48 loMthetho oYilwayo kaMasipala wase-Overstrand olungisiweyo ongokuSetyenziswa koMhlaba kaMasipala wowama-2020, sokokuba isicelo sifunyenwe esilungiselelwe ukulungiswa kwesicwangciso sendlu eqhelekileyo kunye nemimiselo yeMeerenbosch ngokuhambelana neCandelo 16(2)(l) ukulungiselela isindululo sophuhliso kwipropati le kuthethwa ngayo.

linkcukacha ezipheleleyo malunga nesi sindululo ziyafumaneka ngeentsuku zomsebenzi phakathi kweyure-08:00 ne-16:30 kwiSebe: Town Planning, 16 Paterson Street, Hermanus. Naziphi na izimvo ezibhaliweyo mazingeniswe ngokwezibonelelo zamaCandelo 51 nelama-52 zalo Mthetho oYilwayo zithunyelwe kuMasipala (16 Paterson Street, Hermanus / (f) 0283132093 / (e) [loretta@overstrand.gov.za](mailto:loretta@overstrand.gov.za)) ngomhla okanye ngaphambi komhla **wama-18 kuJuni 2021**, unike igama lakho, idilesi neenkukacha zonxibelelwano nawe, umdla wakho kwesi sicelo nezizathu zokunika izimvo. Xa ufuna ukubuza into malunga nesi saziso ungatsalela umnxeba **uMnu. H Olivier** kule nombolo 028-313 8900. UMasipala angala ukuzamkela izimvo ezifike emva komhla wokuvalwa. Nabani na ongakwaziyo ukufunda okanye ukubhala makaye kwiSebe loYilo lweDolophu apho igosa likamasipala liya kumncedisa azibhale izimvo zakhe.

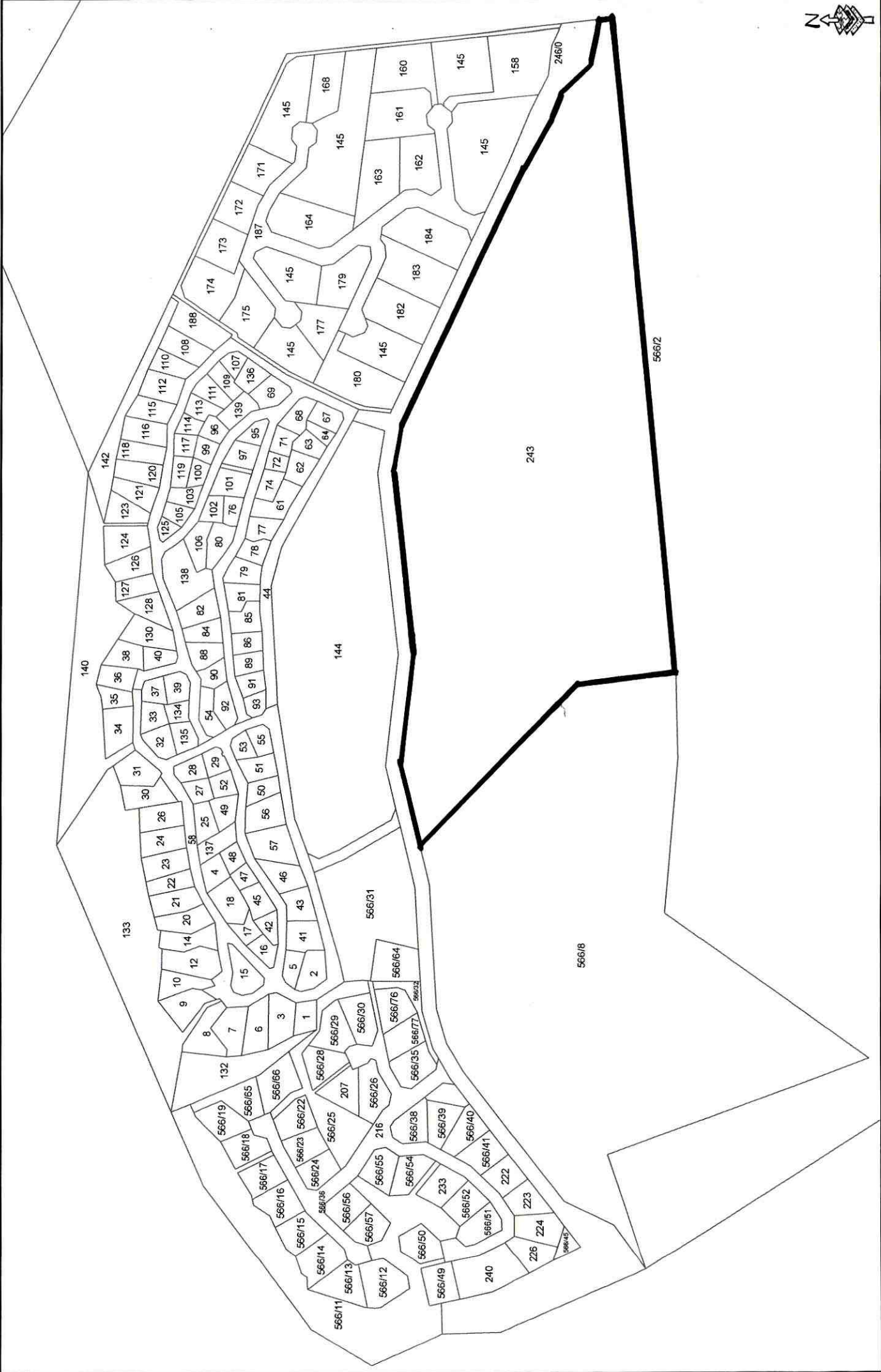

Locality Map  
**MEERENBOSCH**

**AMENDMENT TO MEERENBOSCH BUILDING GUIDELINES – AGM 21 Dec 2019**

**BUILDING REGULATIONS**

The purpose of the Building Regulations and Standard Plan Guidelines are to ensure:

- a uniform building style and aesthetic standards are maintained for the development;
- the established character and ambience of the development are retained and protected;
- compliance in the development with relevant municipal requirements and regulations, as well as with National Building Regulations and Standards as amended from time to time.

The changes provide a better use of the land at Meerenbosch with the only impact being the limited impact on to the “look and feel” of Meerenbosch. As the style was developed over time, this is just a further chapter in the development of the Meerenbosch style and an enhancement of the character that uniquely personifies Meerenbosch

**GENERAL INFORMATION**

Meerenbosch is part of the greater Middlevlei Estate governed by a Master Home Owners Association. It was established as a caravan park pre 1992 and during 1996, as part of the phased development of Middlevlei, subdivided into plots of different sizes and transferred to a Share Block Scheme. All the shares, giving land use rights, were sold to the public. During 2007/2008 the Share Block Scheme transferred all the subdivided own title plots (stands) to the shareholders and the Meerenbosch HOA was established.

Initially the plots continued to be used as caravan and tent stands, but slowly the caravans were replaced by caravan-sized wooden structures that until today gives Meerenbosch its unique building style. Later on the wooden structures were extended to replace the tent extension of a caravan and the inclusion of bathrooms/toilets. This made the 3x communal ablutions redundant and they were demolished.

Still later, the double storey structures came, but they still remained within the original footprint of a large caravan and tent (6m x 8m). Thereafter came chimneys, braai places, storage boxes, water tanks, etc. The important point is that the Meerenbosch-style structures developed over time, resulting in several versions of structures present at Meerenbosch today, reflecting the changes over the years.

Due to the considerable increased cost of owning a plot (HOA levies, rates & taxes, etc.) and bank finance that became available, the need for more “living space” within the approved 6m x 8m footprint became important and was requested by owners.

**MUNICIPAL BUILDING REGULATIONS**

Since the acceptance of the current 2011 Meerenbosch Building Regulations many changes in the Municipal Building Regulations and Standards have been made. These changes have now also been brought into the 2019 update of the Meerenbosch Building Regulations (e.g solar panels, etc).

This document is to record the motivation for the 2019 changes to the 2011 Meerenbosch Building Regulations.

## 1. NEW 2500 LITRE WATER TANKS (ABOVE GROUND)

Meerenbosch is rich in Milkwood trees and flora. Owners are encouraged to retain the bush atmosphere by preserving the flora. Water tanks have been allowed for many years if placed underground or beneath the ground floor of the building. Due to the drought during 2018 and the restrictions placed on the availability of water it was prudent for owners to request new external water tanks (above ground) so that rainwater could be stored for the watering of vegetation from time to time.

### (A) PROPOSED DEVELOPMENT

Add 1x 2500 litre water tank above ground next to the dwelling

### (B) CHARACTER OF THE ENVIRONMENT

The colour to blend in with the environment

### (C) DESIRABILITY OF THE PROPOSED UTILISATION

To provide water for the preservation of vegetation due to water restrictions

### (D) INVESTIGATIONS CARRIED OUT IN TERMS OF OTHER LAWS WHICH ARE RELEVANT TO THE CONSIDERATION OF THE APPLICATION

None

### (E) THE IMPACT OF THE PROPOSED LAND DEVELOPMENT ON MUNICIPAL ENGINEERING SERVICES

Small footprint and no impact on engineering services.

### (F) CONSIDERATION OF FORWARD PLANNING AND LAND USE DOCUMENTS

None

### (G) PLANNING PRINCIPLES

Spatial justice: Limit the impact on to the "look and feel" of Meerenbosch

Spatial sustainability: Environmentally sensitive

Efficiency: Optimise the availability of rainwater

Spatial resilience: Provides water for own vegetation

Good administration: N/A

## 2. STORAGE BOXES

Storage boxes were approved many years ago to provide storage space for canoes, braai equipment, etc. Unfortunately, the initial approved height of 1.2m does not take into account that as owners grow older, they also grow less agile and cannot access the boxes with ease to get to the contents. Therefore the request was made for the higher boxes.

The Trustees' proposed resolution for the maximum height for the storage box was 1.9m. The meeting, however, decided on a maximum height of "ceiling level". It was agreed that the storage box would not be used as an extension of the house to increase the "footprint".

(A) **PROPOSED DEVELOPMENT**

Increase the height of external storage boxes from 1.2m to "ceiling level".

(B) **CHARACTER OF THE ENVIRONMENT**

External storage boxes already exist. Meerenbosch building style also to be used on the extensions. Footprint of dwelling remains (6m x 8m).

(C) **DESIRABILITY OF THE PROPOSED UTILISATION**

Owners grow older and less agile and have difficulty in getting to or reaching the contents in the storage boxes on their hands and knees.

(D) **INVESTIGATIONS CARRIED OUT IN TERMS OF OTHER LAWS WHICH ARE RELEVANT TO THE CONSIDERATION OF THE APPLICATION**

None

(E) **THE IMPACT OF THE PROPOSED LAND DEVELOPMENT ON MUNICIPAL ENGINEERING SERVICES**

None – no change in footprint

(F) **CONSIDERATION OF FORWARD PLANNING AND LAND USE DOCUMENTS**

None

(G) **PLANNING PRINCIPLES**

Spatial justice: The storage boxes are not to open to the inside of the houses to ensure that they do not increase the "footprint" of the house.

Spatial sustainability: N/A

Efficiency: Economic use of the limited storage space without increasing the footprint.

Spatial resilience: The extension of the boxes will enable older persons to remain self-sustained.

Good administration: N/A

### 3. ENCLOSURE OF BALCONIES ( First Floor)

The double storey houses all have 1.5m x 6m balconies covered by the roof. Although the original thinking was that the balconies would provide a special atmosphere for enjoyment, in reality this seldom materialised and the balconies became “white elephants” and mostly a place for washing to dry. Furthermore, for a normal family the first-floor area is marginally too small for the stairs, a small bathroom and the required 3 bedrooms. By allowing the balcony to be fully (or half) enclosed, it provides for more living space without limiting the views or benefits of a balcony. The proviso is that the Meerenbosch building style be encapsulated without increasing the footprint (6m x 8m) of the structure.

**(A) PROPOSED DEVELOPMENT**

An option for new and existing dwellings to enclose the first-floor balcony of double storey's in full (or half) to provide for more living space without increasing the footprint (6m x 8m) of the house

**(B) CHARACTER OF THE ENVIRONMENT**

Meerenbosch building style to be retained.

**(C) DESIRABILITY OF THE PROPOSED UTILISATION**

Increased living space without an increase in the footprint. Better use of the footprint.

**(D) INVESTIGATIONS CARRIED OUT IN TERMS OF OTHER LAWS WHICH ARE RELEVANT TO THE CONSIDERATION OF THE APPLICATION**

None.

**(E) THE IMPACT OF THE PROPOSED LAND DEVELOPMENT ON MUNICIPAL ENGINEERING SERVICES**

None – no change in footprint

**(F) CONSIDERATION OF FORWARD PLANNING AND LAND USE DOCUMENTS**

None – no change in footprint

**(G) PLANNING PRINCIPLES**

Spatial justice: No impact on footprint. Options for the owner to have (1) a full balcony, (2) no balcony or (3) half a balcony. Houses with “views” can still retain their views and those without views can better utilise their footprint for space living.

Spatial sustainability: Better use of space

Efficiency: Economic use of the limited space without increasing the footprint.

Spatial resilience: The closure (or half closure) of the balcony will provide for more living space.

Good administration: N/A

#### 4. ENCLOSURE OF PATIO OR STOEP (ground floor)

The older houses are all single-storey houses, and all have 2m x 6m patios covered by the roof. The owners of single-storey houses also need more living space. These houses have the same footprint as double storey's (6m x 8m), but the cost to change a single storey into a double storey is enormous and amounts to nearly the same as the total value of the single storey house (and plot). By allowing the patio to be fully (or half) enclosed, it provides for more living space without limiting the access in and out of the house. The proviso is that the Meerenbosch building style be encapsulated without increasing the footprint (6m x 8m) of the structure.

To retain fairness between single and double storey house owners, the extension of the patio/stoep should also apply to the double storey houses to ensure the best use of the footprint also for them.

**(A) PROPOSED DEVELOPMENT**

An option for new and existing dwellings to enclose the patio/stoep of single and double storey's in full (or half) to provide for more living space without increasing the footprint (6m x 8m) of the house

**(B) CHARACTER OF THE ENVIRONMENT**

Meerenbosch building style to be retained. If fully enclosed, some houses will then not have a patio/stoep and will in future not be able to extend or a patio/stoep.

**(C) DESIRABILITY OF THE PROPOSED UTILISATION**

Increased living space without an increase in the footprint. Better use of the footprint.

**(D) INVESTIGATIONS CARRIED OUT IN TERMS OF OTHE LAWS WHICH ARE RELEVANT TO THECONSIDERATION OF THE APPLI CATION**

None

**(E) THE IMPACT OF THE PROPOSED LAND DEVELOPMENT ON MUNICIPAL ENGINEERING SERVICES**

None – no change in footprint

**(F) CONSIDERATION OF FORWARD PLANNING AND LAND USE DOCUMENTS**

None – no change in footprint

**(G) PLANNING PRINCIPLES**

Spatial justice: No impact on footprint. Options for the owners of both single and double storey's to have (1) a full patio/stoep, (2) no patio/stoep or (3) half a patio/stoep.

Spatial sustainability: Better use of footprint for living space, but future extensions limited if fully enclosed.

Efficiency: Economic use of the limited space without increasing the footprint.

Spatial resilience: The closure (or half closure) of the patio/stoep will provide for more living space.

Good administration: N/A

**5. OTHER SMALLER MATTERS**

- a. **Freestanding toilets.** Since in-house toilets have been approved on every plot the reference in the regulations to “freestanding toilets” on each plot have become irrelevant. The 3x ablutions on Meerenbosch have also been demolished. Contractors on site, however, when building a new structure, are required by Municipal regulations to provide temporary toilet facilities for the on-site.
- b. **Latte windbreaks.** The use of windbreaks made of “latte” were introduced as a temporary and practical measure to create pleasant external areas on the small plots, protected from dust due to the high winds that prevail. The windbreaks also provide a level of privacy where a house is built near to the other.
- c. **Thatched shade structures.** The thatched shade structures have become irrelevant over the last 10 years.
- d. **Wooden decks.** In the previous Building Regulations, paving on an erf was handled differently to wooden decks. Over time wooden decks have been preferred by some owners over paving. The same 50% parameter, as for paving, was then used. In the new Regulations this irregularity between paving and wooden decks were rectified.
- e. **Pitch of roof.** The maximum height of a double story house is 6,0m (measured from the finished floor level to the top of the ridge of the roof). When the Municipal Building Regulations changed the minimum ceiling height of habited rooms, the height of the ceilings to be increased. This increase resulted in the roof pitch to be adjusted to 15° to allow for the ceiling height while remaining within the 6m height of the house.

**(B) CHARACTER OF THE ENVIRONMENT**

No impact

**(C) DESIRABILITY OF THE PROPOSED UTILISATION**

Practical changes to better living at Meerenbosch

# **BUILDING REGULATIONS FOR MEERENBOSCH HOMEOWNERS ASSOCIATION**

(Annexure B to the Constitution of Meerenbosch Homeowners Association) Updated and Amended: 2019-12-21

## **1. INTRODUCTION**

- 1.1 Before any improvement is implemented on an erf (for example building a house or a braai place, erecting a fence or a wooden deck, laying paving or erecting a retaining wall or adding a water tank, a written application must be submitted to Meerenbosch Homeowners Association. The application must contain a detailed plan, list of building materials, specifications as well as a site plan indicating the exact position of the proposed improvement.
- 1.2 Work on implementing an improvement on an erf may only commence once written approval has been obtained by the owner from Meerenbosch Homeowners Association and other formalities (for example obtaining municipal approval and depositing a building deposit or obtaining the approval of all the neighbour as in the case of a water tank)), have been concluded.
- 1.3 In accordance with its Constitution, Meerenbosch Homeowners Association will ensure that any improvement on an erf where such improvement has been implemented without permission from the Association will be removed or dismantled.
- 1.4 These Building regulations are subordinate to the municipal Building Regulations and Standards
- 1.5 The purpose of the Building Regulations and Standard House Plans are to ensure:
  - 1.5.1 a uniform building style and aesthetic standards are maintained for the development;
  - 1.5.2 the established character and ambience of the development are retained and protected;
  - 1.5.3 compliance in the development with relevant municipal requirements and regulations, as well as with National Building Regulations and Standards as amended from time to time.

## **2. TYPES OF HOUSES TO BE ERECTED**

- 2.1 Only a wooden house may be erected on an erf.
- 2.2 Only one house may be erected on an erf.
- 2.3 Only one of the following two types of houses with a total footprint of 6m x 8m may be erected on an erf:
  - 2.3.1 Type 1: a single storey wooden house (6m x 6m) with a ridge-height of 3,9m from the finished floor level with a roof pitch of 28° and a veranda of 6m x 2m under the roof.
  - 2.3.2 Type 2: a double storey wooden house (6m x 6m) with a ridge-height of 6,0m from the finished floor level with a roof pitch of 15° and a veranda of 6m x 2m and a balcony of 6m x 1,5m under the roof.
- 2.4 On condition that the uniform building style and aesthetic standards are maintained
  - 2.4.1 The veranda of all houses (single and double storey) may be enclosed the entire length of the veranda or only half.
  - 2.4.2 The balcony of all double storey houses may be enclosed either for the entire length of the balcony or only half.
- 2.5 The external detail of the house must comply with the Standard House Plans as provided by the Meerenbosch Homeowners Association. The Standard House Plans will be updated from time to time as municipal requirements and regulations change and new plans are approved by the municipality.
- 2.6 No cement or brick or concrete work is allowed above the ground floor level of the house (except for an indoor braai or fireplace that can be secured by brick and cement).

### **3. PLACING OF HOUSES**

- 3.1 In as far as the placing of a new house is concerned, the position of existing houses must be taken into account as far as view and privacy is concerned. This ruling is within the context of good neighbour relationships and cannot be enforced by Meerenbosch Homeowners Association.
- 3.2 A house must be built within the 1,5m building line and may only with permission from Meerenbosch Homeowners Association as well as the adjacent owner (if applicable), be built closer to the erf boundary than the 1,5 m building line.
- 3.3 In the event of an erf having an excessive slope (or for any other reason), application can be made to have the house positioned on poles as per certified engineering specifications. The maximum height of the ground floor above the natural ground level must be to the satisfaction of the Overstrand Municipality.
- 3.4 As of 29 July 2008, no construction on waterfront erven may occur below the 5m MSL contour or within 32 m from the edge of the lagoon.

### **4. ADDITIONAL IMPROVEMENTS ALLOWED ON ERVEN**

- 4.1 An indoor braai or fire place is allowed as per specifications in this Building Regulations.
- 4.2 A horizontal storage box may be erected fixed to the outside of a house as per specification in this Building Regulations.
- 4.3 Fences are allowed between erven as per specifications in this Building Regulations. The adjacent owner must give written permission before a fence can be erected.
- 4.4 Outside braai places including "wash up" areas from brick and cement are allowed as per specifications in this Building Regulations.
- 4.5 The placement of storage tanks underneath houses for the catchment of rainwater is allowed as indicated on the Standard House Plans.
- 4.6 The placement of solar panels on roofs is allowed.
- 4.7 A windbreak made from "latte" (or made from any other material) is allowed on erven provided permission has been obtained from the trustees

### **5. STRUCTURES NOT ALLOWED ON ERVEN**

- 5.1 No gate is allowed on an erf and no fencing may be erected on any street front of an erf.
- 5.2 No built-in steel braai or built in steel fire place or pizza oven is allowed outside of the house on an erf.
- 5.3 No swimming pool or splash pool or bubble pool is allowed on an erf.
- 5.4 No free-standing toilet ("toilet huisie) is allowed on erven.

### **6. PROCEDURE FOR BUILDING A HOUSE**

- 6.1 Obtain the relevant building information and a copy of the Standard House Plans specifying the external detail of the house from the trustee committee.
- 6.2 Make contact with the A19 building inspector and obtain relevant building information.
- 6.3 Obtain a proper building plan for the proposed house drawn by a registered draftsman. The plan must contain the following:
  - 6.3.1 a site layout plan showing the position of the house, building lines and the sewerage connection;

- 6.3.2 detailed dimensions of the foundations as well as all other required dimensions of the house for example roof height from floor level and roof pitch;
  - 6.3.3 a window and door schedule for all four sides of the house;
  - 6.3.4 material specifications;
  - 6.3.5 full retaining wall, paving and boundary wall detail (where applicable).
- 6.4 Submit the building plan to the trustee committee for approval.
  - 6.5 Make the required payment with regards the building deposit. The building deposit will be determined from time to time by the trustee committee.
  - 6.6 Obtain a stamp of approval from the trustee committee on the plans once the plans are approved. The trustee committee keeps one copy of the plans for filing and reference purposes, until the building work is completed and a certificate of occupation is issued.
  - 6.7 Submit the approved (and stamped) plan to the local authority for approval.
  - 6.8 Building may only start once:
    - 6.8.1 all plans have been approved as required;
    - 6.8.2 the building deposit has been paid as well as all outstanding levies;
    - 6.8.3 a site toilet has been erected for the builder;
    - 6.8.4 once the land surveyor has confirmed the boundaries of the erf.
  - 6.9 The owner is the responsible person as far as the building activity is concerned and conducts the building activity and all contractual, legal, insurance and other aspects related to it, at his own risk.

## **7. OTHER IMPORTANT REQUIREMENTS, RULES AND REGULATIONS**

- 7.1 Foundations: The maximum height of a concrete foundation is 300 mm above the natural ground level (three to four brick layers). Filling up around a foundation may take place on condition that the final filled level matches the natural ground level of the erf. In the event of an alternative house being built, the old house must be removed within three (3) months after completion of the new house. The foundation of the old house must also be removed within three (3) months after completion of the new house.
- 7.2 A19 Certificate: Before the walls of the house or the roof are cladded, an A19 certificate must be obtained from a qualified and registered A19 building inspector certifying a sound structure for the building. The Home Owners Association may insist on verification in this regard and can demand removal of any cladding until such certificate has been obtained.
- 7.3 Building period: a Building period of six (6) months is allowed after which all building rubble and materials must be removed from the erf. If it is anticipated that the building period is going to take longer than six (6) months, the outside of the house must be finished first (completely) and all building material and rubble removed from the erf. The house may then be finished from the inside over a longer period of time.
- 7.4 Building material: The storage of building material or mixing of concrete may not take place in the street in front of the house.
- 7.5 Inspections: Regular inspections shall be conducted throughout the building period by the relevant inspectors. It is the responsibility of the owner to arrange for such inspections. The following inspections are recommended:
  - 7.5.1 foundations
  - 7.5.2 wall structures before cladding (see 7.2)
  - 7.5.3 roof structure before cladding
  - 7.5.4 wiring
  - 7.5.5 sewerage

- 7.5.6 final inspection
- 7.6 Additional Inspections: the local authority building inspector and/or Meerenbosch Homeowners Association may carry out additional inspections at any time.
- 7.7 Craftsmanship: Only skilled tradesmen and high quality workmanship is allowed. If Meerenbosch Homeowners Association is of the opinion that workmanship is sub-standard or building activities are in breach with the Building regulations, the builder will be asked to vacate the building site and a professional opinion will be sought. If confirmation of sub-standard building activities is obtained, the owner will be notified and instructed to rectify the situation before any further building activities will be allowed.
- 7.8 Building plans: A copy of the approved building plan must at all times be available on site during normal working hours.
- 7.9 Building lines: The building line is 1,5m. No structures (including braai places and storage boxes) are allowed within 1,5m of the erf boundaries. Written permission must be obtained from the adjacent owner as well as Meerenbosch Homeowners Association for any exceptions to this rule.
- 7.10 Construction times
- 7.10.1 Weekdays: 07h30 to 17h00
- 7.10.2 Saturdays: 09h00 to 17h00
- 7.10.3 Holidays: 09h00 to 17h00
- 7.10.4 Sundays: no construction activities allowed
- 7.10.5 December: no construction activities allowed from 16 December to 14 January
- 7.10.6 Easter: no construction activities allowed from Easter Friday to Easter Monday
- 7.11 Contractors, sub-contractors and workers:
- 7.11.1 Only registered builders may build houses in Meerenbosch.
- 7.11.2 The Meerenbosch Homeowners Association caretaker or the duly appointed person must be notified at all times when a builder or sub-contractor or worker is entering Meerenbosch. This rule is applicable for any type of building or maintenance activity on an erf.
- 7.11.3 Identification of workers must be arranged via the caretaker or the duly appointed person.
- 7.11.4 Contractors or sub-contractors or workers may not sleep over on an erf.
- 7.11.5 A standard builder's toilet must be available at all times on site.
- 7.11.6 Contractors or sub-contractors or workers may only make use of the site toilet.

## 8. GENERAL MATERIAL SPECIFICATIONS (MINIMUM REQUIREMENTS)

### 8.1 General

- 8.1.1 Only timber structures will be allowed and only in accordance with the specifications as per approved plan.
- 8.1.2 All building work carried out must comply to SABS 0400 in the National Building Regulations.
- 8.1.3 Only SABS approved treatment of timber will be allowed. Timber may not be treated on site.

### 8.2 Floors

- 8.2.1 Filling must be well compacted.
- 8.2.2 Concrete floor layer (100mm) with 25mm screed and 250 micron under floor damp proof membrane.

### 8.3 External Finishes

- 8.3.1 Cladding: Single 130mm or 138mm SA Pine "loglap" (minimum thickness of 32mm).
- 8.3.2 Wood finish: Treat with "mahogany" colour wood sealant (clear wood treatment is not

allowed).

8.3.3 Painting of door and window frames and window sills with any other colour than "mahogany" is prohibited.

#### 8.4 Roofs

8.4.1 Roof Trusses: As indicated on the Standard House Plans and to be designed for "Victorian Profile" fibre cement or Chromadeck roof sheeting.

8.4.2 Under roof layer: White PVC roof plastic or "Sisalation" or "Alucushion".

8.4.3 Roof Sheeting: "Victorian Profile" fibre cement or Chromadeck roof sheeting.

8.4.4 Barge and fascia: Standard fibre cement or PVC – colour white or green (as roof sheets).

8.4.5 The colour for the roof sheets and capping is "tennis court green" or equivalent.

8.4.6 Gutters: White PVC or aluminium type. Gutters are not compulsory but are recommended in order to facilitate rainwater flow.

8.4.7 Roof overhang: 300mm.

#### 8.5 Windows and doors

8.5.1 Sliding doors: Bronze or natural aluminium or meranti timber (all sliding doors to have the same colour code).

8.5.2 Window frames: Bronze aluminium or natural aluminium or meranti timber (all window frames to have the same colour code).

#### 8.6 Columns

8.6.1 Timber columns 114mm x 76mm or PAR 96 mm x 96 mm, appropriately provided with galvanised footing piece. (Steel piping and tar poles are not allowed).

8.6.2 The use of a single steel beam placed horizontally to support the upper floor is allowed.

8.6.3 The use of a single steel beam placed horizontally to support above a sliding door is allowed.

8.6.4 The balcony must be supported with three (3) 150 mm x 150 mm vertical timber columns from the ground floor veranda. Should only (2) vertical timber columns be used, then in addition a single steel beam placed horizontally to support the upper floor is mandatory.

#### 8.7 Chimneys

8.7.1 Only one (1) steel chimney (external or internal) may be installed.

8.7.2 Maximum size: 470 mm x 340 mm or 226 mm diameter.

8.7.3 Internal chimney shall not be closer than 200 mm from any wooden structure. The wooden structure must also be clad with 500 mm x 3 mm fibre cement sheets to limit the risk of fire.

8.7.4 Where a chimney is closer than 200mm from any wooden structure then that structure must be protected with 25mm thick glass wool and 3mm fibre cement sheeting, unless heat proof 316 aluminium pipes are used.

8.7.5 External chimneys must be at least 300mm clear of any wooden structure. Where a chimney penetrates a wooden structure a lining of 25mm thick glass wool and a 3mm thick fibre cement covering an area of 100mm around the opening is required.

8.7.6 Chimneys must be painted with heat resistant paint if galvanised steel is used, to prevent corrosion, but not necessary if stainless steel is used.

8.7.7 Chimneys may not be covered by brick and cement or any other material.

8.7.8 A spark proof cowl must be fitted for fire prevention.

8.7.9 Some chimneys are constructed of stainless steel which do not require painting or heat proofing with glass wool if heat proof stainless steel pipes are used. Spark proof cowls should be required for wooden houses as a safety measure.

## **9. FENCING**

### **9.1 General**

- 9.1.1 No fencing may be erected on any street front.
- 9.1.2 Fencing where possible must be obtained through planting trees or shrubs.
- 9.1.3 Fences (other than hedging) may not damage natural growth within the development.
- 9.1.4 No shade netting for fencing or closures is allowed.
- 9.1.5 The erection of or alteration to a fence is subject to written approval by the adjacent neighbour.

### **9.2 Specifications for fencing**

- 9.2.1 Treated SA Pine (colour "mahogany") or insert panels as approved with concrete posts.
- 9.2.2 Maximum height from ground level is 1,8m and maximum length is 10m per erf. An erf flanked by three other erven may therefore have 30m of fencing in total.
- 9.2.3 Fencing to side boundaries of any specific erf may not be constructed closer than 2.5m from any street front.
- 9.2.4 Fencing on any other position on an erf except on the boundary between erven will only be considered in exceptional cases.
- 9.2.5 "Ranch Style" fencing is permitted only in exceptional circumstances and with the written permission of the committee as applicable to street fronts and side boundaries. (Round vertical timber poles 1m high and 2.4m apart with two round horizontal poles in between shall constitute interpretation of a "Ranch Style" fence). Only treated timber is allowed and the colour mahogany is applicable.

## **10. PAVING**

### **10.1 General**

- 10.1.1 Existing plants and trees must be taken into account when paving is done.
- 10.1.2 The maximum permissible surface that may be paved may not exceed 50% of the total area of the erf.

### **10.2 Specifications for paving**

- 10.2.1 Paving on an erf must be uniform (i.e. different types of paving material will not be permitted on any one specific erf).
- 10.2.2 Only paving on a properly constituted and compacted bedding layer is permitted.

## **11. RETAINING WALLS**

### **11.1 General**

- 11.1.1 Aesthetic appeal shall be an important point in approval of a retaining wall.
- 11.1.2 It is the responsibility of the owner to ensure the retaining wall is eventually completely covered by plants or groundcovers (preferably of a type needing minimum watering).

### **11.2 Specifications for retaining walls**

- 11.2.1 Preference will be given to "Loffelstein" or similarly approved retaining blocks appropriate for stabilisation of sand banks.
- 11.2.2 Should alternative building materials be used for retaining sand then such materials must be subject to an appropriate engineering certificate.
- 11.2.3 An engineer's certificate will be required for retaining wall higher than 1,5m.

## **12. BRAAI PLACES**

### **12.1 General**

- 12.1.1 Braai places must be placed in such a manner that plants and/or trees are not in any way damaged or affected.
- 12.1.2 Outside braai places are not allowed to be enclosed and no chimneys are allowed.
- 12.1.3 No built in or freestanding (fixed) metal braai places or pizza ovens are allowed outside houses.
- 12.1.4 The building of tables or washing up structures from brick adjacent to braai places are allowed. Aesthetic appeal shall be an important point in approval of such a structure.
- 12.1.5 Indoor braai places may be secured by brick and cement.

### **12.2 Specifications for braai places**

- 12.2.1 The maximum height allowed for an outside braai including any table or washing up structures is 1000 mm.
- 12.2.2 Preference must be given to outside braai places which are low to the ground. This is to ensure minimum visual impact.
- 12.2.3 A braai inside a house may not extend outside the house. Only the chimney may extend outside the house.

## **13. ELECTRICITY**

- 13.1 Electrical connections may only be performed by a qualified and registered electrician.
- 13.2 Only 10 mm<sup>2</sup> "Airduct" supply cable is acceptable.
- 13.3 Connections must be arranged through the municipality in conjunction with the appropriate registered electrical contractor.
- 13.4 Electrical installations must comply with the requirements of SABS 0142 and a Certificate of Compliance must be issued through the accredited person by law for all new installations and change of ownership.
- 13.5 Only approved pay meters may be used in order to comply and be compatible with the payment system of the local Authority.

## **14. WATER**

- 14.1 On every erf the owners are responsible for providing an acceptable water meter that is placed in a position where the readings can easily and accurately be taken.
- 14.2 Bypassing the water meter on an erf (direct connection to the main water line) is strictly prohibited.

## **15. SEWERAGE**

- 15.1 A sewerage connection between a house and the main sewerage line (in the road) must be supplied with a rodding eye.
- 15.2 A sewerage connection may only be conducted by a registered qualified plumber.
- 15.3 Care must be taken to ensure that no stone, gravel, sand or other building rubble gains access to the sewerage system during connection.

## **16. STORAGE BOX**

16.1 Only one (1) storage box is allowed per house and must be fixed to the house.

16.2 Specifications for storage boxes

16.2.1 The storage box must be of the same wood cladding as the house.

16.2.2 The maximum length is 6 m and the box may not extend past the wall of a house.

16.2.3 The maximum depth (away from the wall) is 1 m.

16.2.4 The maximum height (above floor level) for a double storey house and for a single storey house, is ceiling level. The increased storage box may not become another room or part of the house.

## **17. WATER STORAGE AND SOURCING (ABOVE AND UNDERGROUND)**

17.1 General

17.1.1 The placement of water tanks under a house or in an inconspicuous area on the erf, for storage of rainwater, is allowed pending approval of the trustees and all the neighbours, based on aesthetic appeal.

17.1.2 The placement of water tanks under a house may not cause the house to have the appearance of a "triple storey" house.

17.1.3 The water tank storage area may only be used for the storage of the water tanks.

17.2 Specifications for above and underground water storage tanks

17.2.1 The water tank storage area may form part of the foundations of the house, on condition that the final foundation of the house is 300 mm (three to four bricks) above the ground level (refer to paragraph 7.1).

17.2.2 The entrance to the water tank storage area under a house must be a trap door located inside the house or a trap door on the veranda. No formal staircase may be erected but only a stepping ladder.

17.2.3 An area just big enough for the water tanks is allowed, such area may not be utilised for storage purposes and no additional storage area will be allowed (Specifications to be in line with those indicated on the Standard House Plans).

17.2.4 In the event of a house being constructed on poles, placement of water tanks underneath the house is not allowed.

17.2.5 Water tanks placed above the ground are limited to one (1) and may not be larger than 2500 litres and is to be either of a green or sand colour depending on aesthetics.

17.2.6 A Water tank above the ground must be placed adjacent to the house and the piping from the gutters to the tank shall be as unobtrusive as possible and the visibility may not distract aesthetically. Approval from the neighbours and the trustees is required before installation.

## **18. WOODEN DECKS**

18.1 General

18.1.1 Wooden decks may be erected with the main objective being a substitute for paving.

18.1.2 Wooden decks may be erected over a slope in order to create practical living space.

18.1.3 The level of the wooden decks may not be above the finished floor level of the house

18.1.4 Wooden decks may not be used to create additional balconies to a double storey house.

18.1.5 In the event of a house being built on poles, additional wooden decks may be added on to extend the ground floor deck area of the house provided this is based at the front of the house and that the deck and the house do not cover more than 50% of the erf.

## 18.2 Specifications for wooden decks

18.2.1 Only new timber may be used.

18.2.2 Only treated timber may be used.

18.2.3 The wooden deck must be painted. Colour: Mahogany (same as for houses).

## 19. HOUSE ON POLES

### 19.1 General

19.1.1 In the event of an erf having an excessive slope, or for any other special reason, an application may be made to have the wooden house built on poles (instead of the standard concrete foundation).

19.1.2 Under no circumstances will an application be considered when it is clear that the objective is to park vehicles under the house or to improve the view from the house.

19.1.3 The area under the wooden deck (ground floor level) shall not be used for any other purpose than supporting the house.

19.1.4 The area under the wooden deck (ground floor level) shall not be paved or tiled.

19.1.5 The area under the wooden deck (ground floor level) shall not be closed off by any means except by natural vegetation.

### 19.2 Specifications for a house on poles

19.2.1 The poles supporting the house shall be 200 mm diameter.

19.2.2 A minimum of 12 poles shall be planted to support the house.

19.2.3 The placement of the poles in the ground shall be as per specified building standard.

19.2.4 The wooden deck (ground floor level) will be 9 (nine) meters long (maximum) and 7 (seven) meters wide (maximum).

19.2.5 The wooden deck (ground floor level) allows for a 6 m x 6 m house, a 6 m x 2 m ground floor veranda, a 6 m x 1 m storage box (maximum) behind the house and a 9 m x 1.5 m "boardwalk" to one side of the house. The "boardwalk" allows for a side entrance to the house as well as connecting the ground floor veranda of the house with the back of the house.

19.2.6 The balcony of the house on the first floor is standard 6 m x 1,5 m.

19.2.7 The sewerage connection to the house shall be as unobtrusive as possible.

19.2.8 The external detail of the house must otherwise comply with the Standard House Plans as provided by the Meerenbosch Homeowners Association.

## 20. GAS INSTALLATIONS

20.1 Gas installations in a house must comply with applicable regulations.

20.2 Gas cylinder storage on an erf must comply with applicable regulations.

20.3 Gas fittings or gas installations in a house shall be installed by a qualified person and a certificate of compliance (COC) must be provided.

# MEERENBOSCH UPDATED STANDARD HOUSE PLAN FOR EXTERNAL DETAIL

1. IN ACCORDANCE WITH MBHOA BUILDING REGULATIONS ( UPDATED 2020/10/01)
2. IN ACCORDANCE WITH MUNICIPAL , PROVINCIAL AND NATIONAL BUILDING STANDARDS
3. STANDARD HOUSE PLAN UPDATED : OCTOBER 2020

## GENERAL NOTES :

1. All dimensions to be checked on site and altered to suit conditions where necessary
2. All vegetation matters to be removed
3. Floor covering tiles, electrical fittings, paint and sanitary to owner's spec's
4. All piping and conduit to be installed before cladding work commences.
5. Built-in cupboards to owner's spec's
6. All extensions and alterations to match existing as far as possible.
7. Builder to make him familiar with all the erf contours and pegs.
8. All work to comply to municipal , provincial and the standard building regulations.
9. Closed drainage systems to N.B.R.I Regulations.
10. Building rubble and excess material to be removed from building site by Builder Contractor after completion of contract.Premises to be left in a clean and orderly state.
11. All dimensions in mm unless otherwise stated.

## NEW CHANGES TO EXISTING STANDARD PLAN

### PROPOSED OPTIONS

1. New storage box to max height of 2600mm
  1. Ground storey : Existing livingroom stoep to be enclosed
  2. First storey : One or Both bedrooms balconies to be enclosed
- Balustrades:
1. Height : 1000mm
  2. Gaps of balustrades not exceeding 90mm
- New storage box:
1. Height :2600mm : Width : 6000mm
- Ground / First storey floor height:
1. 2500 mm
- New water JOJO storage tank :2500L ( 1 )
- Others
1. 1430mm X 1925mm
- Ceiling heights: 2500mm/ Roof pitch 15 degrees
2. Thermo Solar panels: Flat Plate Collectors - see drawings





2020/09/45  
SEP 14  
CA  
1:100

PROPOSED  
ADDITIONS

MEERENBOSCH 2020  
NEW STANDARD PLAN

6 Lobos street  
Benfontein 7201  
Tel: (021) 905 10555  
E-mail: cap@cap-lon.com  
Proj. no: D 0993

CAP-LON DESIGNS  
P.A.D

**VIBRACRETE SCREEN WALL**

Material:  
Posts: 50mm X 50mm  
@ 1500mm CC with 300mm  
panels with 114mm x 38mm  
sapine @ 45 angles or latte.

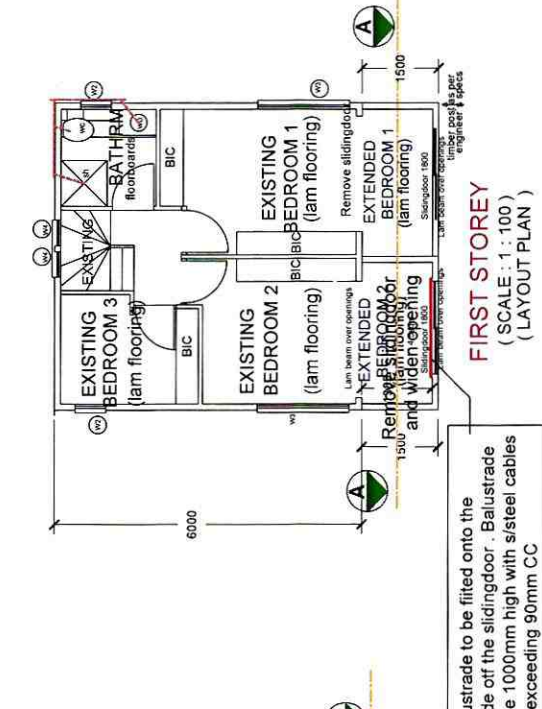
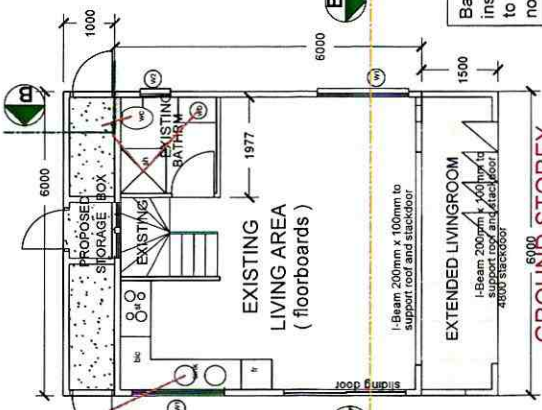
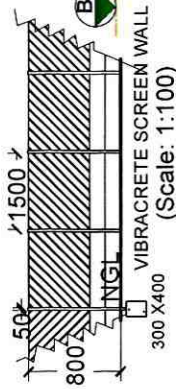

Balustrade to be fitted onto the  
inside of the sliding door. Balustrade  
to be 1000mm high with 6 steel cables  
not exceeding 90mm CC

**STRUCTURAL DETAIL:**

1. Walls : Knotty pine / Rhinoboard internal.
2. Walls: SA pine treated loglap 100mm external.
3. Meranti / Alu doors frames
4. Windows alu framed bronze/ Timber windows treated.
5. Floors : Screed 25mm / Concrete slab 100mm on compacted soil. Floors 1000mm above NGL to have 245 Mesh Reinforcing . Floor finished 300mm max above NGL.

**STORAGE AREA FOR WATER TANKS : STANDARD ( UNDER HOUSE or OUTSIDE)**

1. Diameter : 1430mm ( new tank )
2. Height = 1925 ( 2500L )
3. 3000mm x 6000mm - Height=2,1m ( tank on existing standard plan )
4. Trap door only from steep or inside house.
5. No side doors
6. To eng detail.
7. No steps down

**WALL STRUCTURE DETAIL (1:100)**

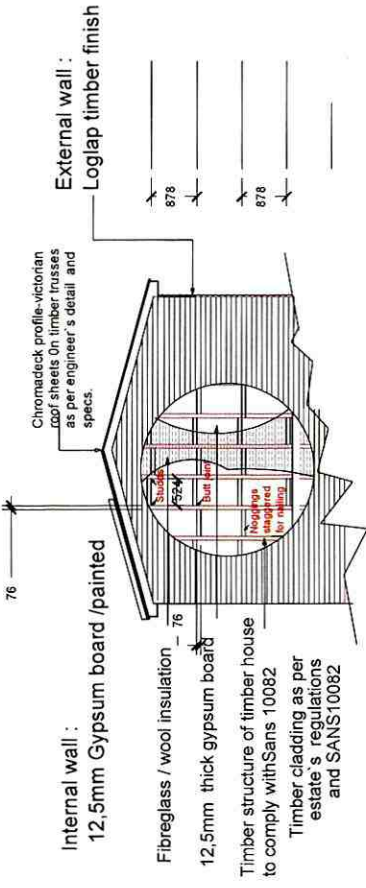

( SCALE : 1 : 100 )

Balustrade to be fitted onto the inside of the sliding door. Balustrade to be 1000mm high with steel cables not exceeding 90mm CC

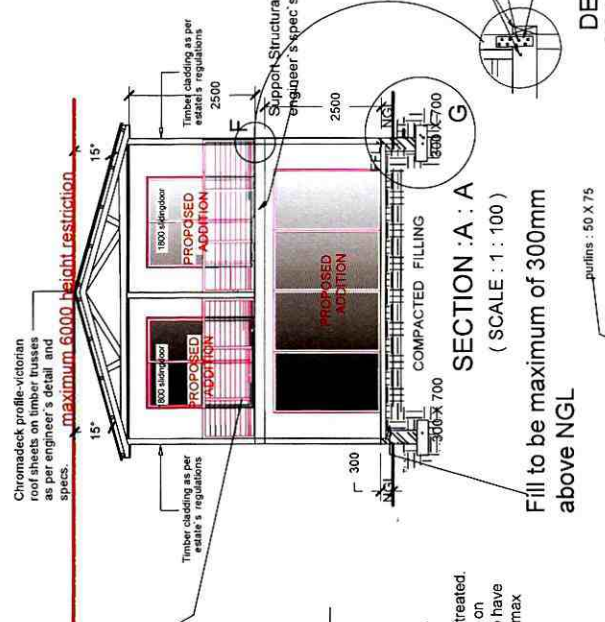

- STRUCTURAL DETAIL:**
1. Walls : Knotty pine / Rhino board internal.
  2. Walls : SA pine treated loglap 100mm external.
  3. Meranti / Alu doors frames
  4. Windows: alu framed bronze/ Timber windows treated.
  5. Floors : Screed 25mm / Concrete slab 100mm on compacted soil. Floors 1000mm above NGL to have 245 Mesh Reinforcing. Floor finished 300mm max above NGL.

LIGHTING	
ITEM NO.	DESCRIPTION
1	RECESSED DOWN LIGHT
2	RECESSED DOWN LIGHT
3	RECESSED DOWN LIGHT
4	RECESSED DOWN LIGHT
5	RECESSED DOWN LIGHT
6	RECESSED DOWN LIGHT
7	RECESSED DOWN LIGHT
8	RECESSED DOWN LIGHT
9	RECESSED DOWN LIGHT
10	RECESSED DOWN LIGHT
11	RECESSED DOWN LIGHT
12	RECESSED DOWN LIGHT
13	RECESSED DOWN LIGHT
14	RECESSED DOWN LIGHT
15	RECESSED DOWN LIGHT
16	RECESSED DOWN LIGHT
17	RECESSED DOWN LIGHT
18	RECESSED DOWN LIGHT
19	RECESSED DOWN LIGHT
20	RECESSED DOWN LIGHT
21	RECESSED DOWN LIGHT
22	RECESSED DOWN LIGHT
23	RECESSED DOWN LIGHT
24	RECESSED DOWN LIGHT
25	RECESSED DOWN LIGHT
26	RECESSED DOWN LIGHT
27	RECESSED DOWN LIGHT
28	RECESSED DOWN LIGHT
29	RECESSED DOWN LIGHT
30	RECESSED DOWN LIGHT
31	RECESSED DOWN LIGHT
32	RECESSED DOWN LIGHT
33	RECESSED DOWN LIGHT
34	RECESSED DOWN LIGHT
35	RECESSED DOWN LIGHT
36	RECESSED DOWN LIGHT
37	RECESSED DOWN LIGHT
38	RECESSED DOWN LIGHT
39	RECESSED DOWN LIGHT
40	RECESSED DOWN LIGHT
41	RECESSED DOWN LIGHT
42	RECESSED DOWN LIGHT
43	RECESSED DOWN LIGHT
44	RECESSED DOWN LIGHT
45	RECESSED DOWN LIGHT
46	RECESSED DOWN LIGHT
47	RECESSED DOWN LIGHT
48	RECESSED DOWN LIGHT
49	RECESSED DOWN LIGHT
50	RECESSED DOWN LIGHT

- GENERAL NOTES:**
1. All dimensions to be checked on site and altered and suit conditions where necessary.
  2. All vegetable matter to be removed.
  3. Floor coverings, tiles, electrical fittings, paint and sanitary ware to owner's specs.
  4. All piping and conduits to be installed before cladding work commences.
  5. Built-in cupboards to owner's specs.
  6. All extensions and alterations to match existing.
  7. The builder to make himself familiar with all the erf contours and site pegs.
  8. All work to comply to local municipal standard and regulations.
  9. Closed drainage systems to NBR1 standards.
  10. All building rubble to be removed by owner/builder after completion of project.
  11. All dimensions in MM

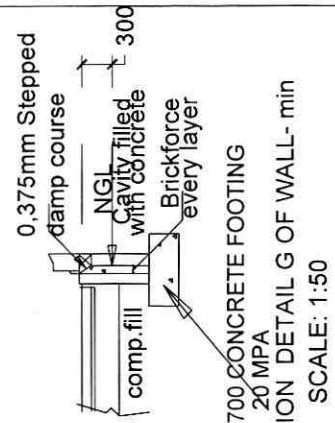

230 X 700 CONCRETE FOOTING  
20 MPA  
SECTION DETAIL G OF WALL- min  
SCALE: 1:50

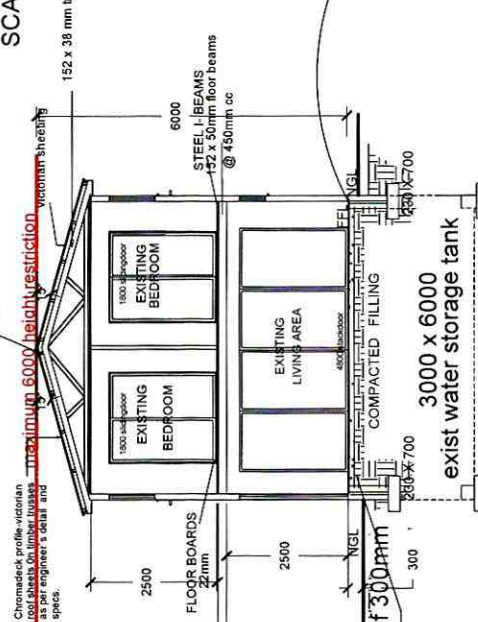

Knotty pine / rhinoboard  
114 X 38mm wooden frame  
100mm SAPine treated- LogLap  
Wall panels secured to slab/wall  
WALL DETAIL  
SCALE: 1:50

- STORAGE AREA FOR WATER TANKS : STANDARD ( UNDER HOUSE or OUTSIDE)**
1. Diameter : 1430mm ( new tank )
  2. Height = 1925 ( 2500L )
  3. 3000mm x 6000mm - Height=2,1m ( tank on existing standard plan )
  4. Trap door only from stoep or inside house.
  5. No side doors
  6. To eng detail.
  7. No steps down

Fill to be maximum of 300mm above NGL

SECTION : A : A  
( SCALE : 1 : 100 )